

A. VARIABLE DISPLACEMENT VANE PUMP

Single pump VP-F8, F15, F20, F23, F26, F30, F40	P. 1~5
Double pump DVP-F12+12, F15+15, F20+20, F23+23, F26+26, F30+30, F40+40	P. 6~7
Variable displacement vane pump+gear pump VPG-F23~F40+HGP-2A	P. 8
High pressure variable displacement vane pump VP5-F20, F25, F30, F40, F54, F70, F86	P. 9~12
High pressure variable displacement double vane pump VP5-F※+※	P. 13

B. AXIAL PISTON PUMP

V-series V15-V70	P. 14~46
VR-series VR15-VR38 Dimensions	P. 47
Tandem pump V series	P. 48
AR-series AR16~AR22	P. 49~50
PV-series PV016~PV270	P. 51~74
Tandem pump PV series	P. 75
PVS, PZS-series PVS-0B-8~PVS-2B-45, PZS-3B-70~PZS-4B-100	P. 76~80

C. FIXED DISPLACEMENT VANE PUMP

Low pressure single pump 50T, 150T	P. 81~84
Low pressure vane pump+gear pump 50T+HGP-2A(3A), 150T+HGP-2A(3A)	P. 85
Low pressure single pump HVP-FAI, DS-11~DS-14	P. 86~87
High pressure single pump PV2R1, PV2R2, PV2R3	P. 88~90
High pressure double pump PV2R12, PV2R13, PV2R23	P. 91
High pressure single pump VQ15~VQ45, SVQ25~SVQ45, DVQ20~DVQ45, HVQ20	P. 92~100
High pressure double pump VQ215~VQ435, SVQ215~SVQ435, DVQ425~DVQ435	P. 101~107
High pressure single pump KT6C, KT6D, KT6E, KT6DS, KT6GC, KT7B, KT7BS	P. 108~116
High pressure double pump KT6CC, KT6DC, KT6EC, KT6ED, KT6GCC	P. 117~123
High pressure triple pump KT6DCC	P. 124~125

D. GEAR PUMP

Single pump HGP-05A, HGP-1A, HGP-2A, HGP-3A	P. 126~132
Double gear pump HGP-22A, HGP-33A	P. 133~134
Gear pump with relief valve PR1, PR2	P. 135~136
Gear pump with relief valve+lift valve PR1+V2064, PR2+V2064	P. 137~138

E. DUMP HOIST PUMP

KP-35, KP-55, KP-75, KP-1403	P. 139~140
------------------------------	------------

F. HAND PUMP, FOOT PUMP, AIR HYDRAULIC PUMP, HI-PRESSURE HAND VALVE

H-B, H-A, H-A2, H-C, F-B, F-C, AP-801, AP-901, AP-1000, AP-3000, AP-3001, HV-700	P. 141~142
--	------------

G. SYNCHRONOUS FLOW DIVIDER

DFM-302~DFM-304	P. 143
-----------------	--------

H. HYDRAULIC MOTOR

Radial hydraulic piston motor B1-MRCN 200~B5-MRCN 3500	P. 144~150
High performance vane motor KVM4C, 4SC, 4D, 4SD	P. 151~154
Gear motor 2MM2U, 2MM1U	P. 155

I. POWER PACK

Manifold functions, DC, AC motors and Specifications	P. 156~159
--	------------

J. ELECTRIC MOTOR

Hollow shaft type	P. 160~164
-------------------	------------

K. LUBRICATOR

One-way rotation oil pump ROP 10A~13A, electro-magnetic coolant pump WE, WL	P. 165
Manual operated lubricator LT series	P. 166
Motor-type engine oil/grease oiler MSK, KCMM, TM series	P. 167~175

VARIABLE DISPLACEMENT VANE PUMP

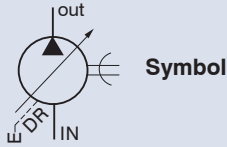

Symbol

VP-F8, 12, 15, 20



A

How to order

VP - F 15 - A ✖ - ✖

- | | |
|---|--|
| 1 | Variable pump |
| 2 | F: Flange mounting type |
| 3 | Nominal No-Load displacement |
| 4 | A: Sharp cut-off type |
| 5 | Pressure adjusting range |
| 6 | Shaft diameter: None: 12.7 (standard) B: 15.88 |

Specifications

Model	No-Load Displacement lpm At 1800 rpm	Pressure Adj. Range (bar)	Rated Speed (rpm)		Max. Pressure (bar)	Weight (kg)
			Max.	Min.		
VP-F8	8	1: 3-20				4.8
VP-F12	12	2: 15-55	1800	800	70	4.8
VP-F15	15	3: 30-70				5.2
VP-F20	20					5.2

Dimensions

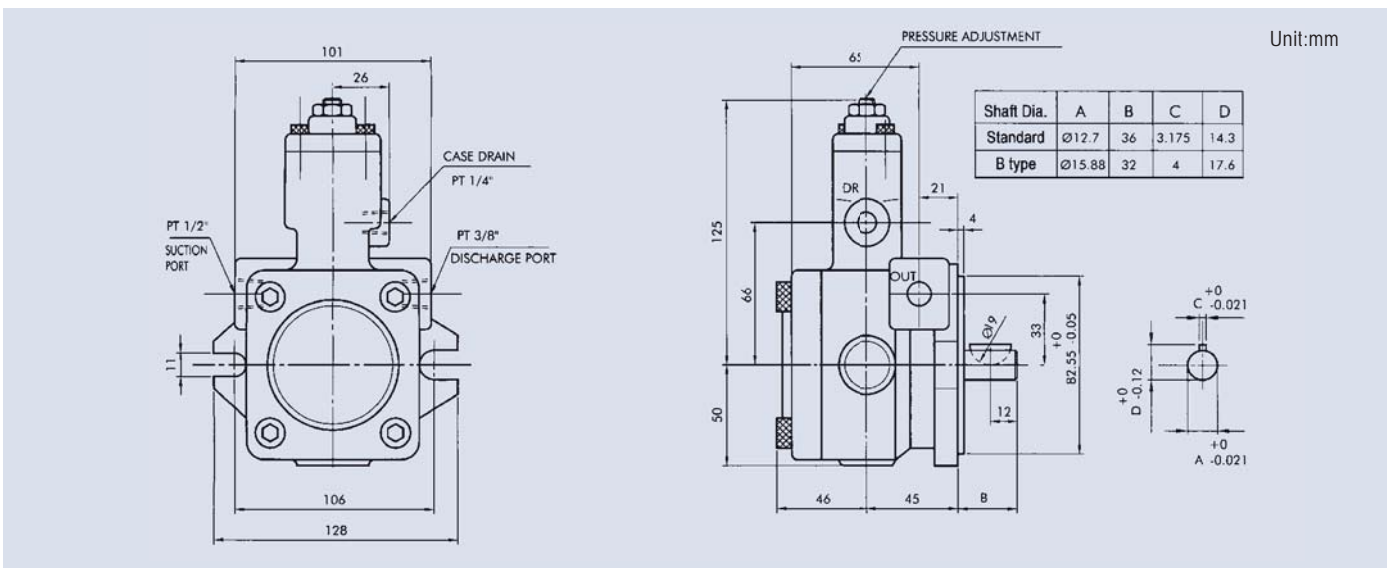

Unit:mm

Shaft Dia.	A	B	C	D
Standard	Ø12.7	36	3.175	14.3
B type	Ø15.88	32	4	17.6

VARIABLE DISPLACEMENT VANE PUMP

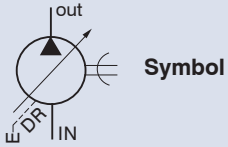

VP-F23, 26, 30, 40

How to order

VP - F 30 - A ✖

- | 1 | 2 | 3 | 4 | 5 |
|---|------------------------------|---|---|---|
| 1 | Variable pump | | | |
| 2 | F: Flange mounting type | | | |
| 3 | Nominal no-load displacement | | | |
| 4 | A: Sharp cut-off type | | | |
| 5 | Pressure adjusting range | | | |

Specifications

Model	No-Load Displacement lpm At 1800 rpm	Pressure Adj. Range (bar)	Rated Speed (rpm)		Max. Pressure (bar)	Weight (kg)
			Max.	Min.		
VP-F23	23	1: 3-20	1800	800	70	9
VP-F26	26	2: 15-55				9
VP-F30	30	3: 30-70				9
VP-F40	40					9

Dimensions

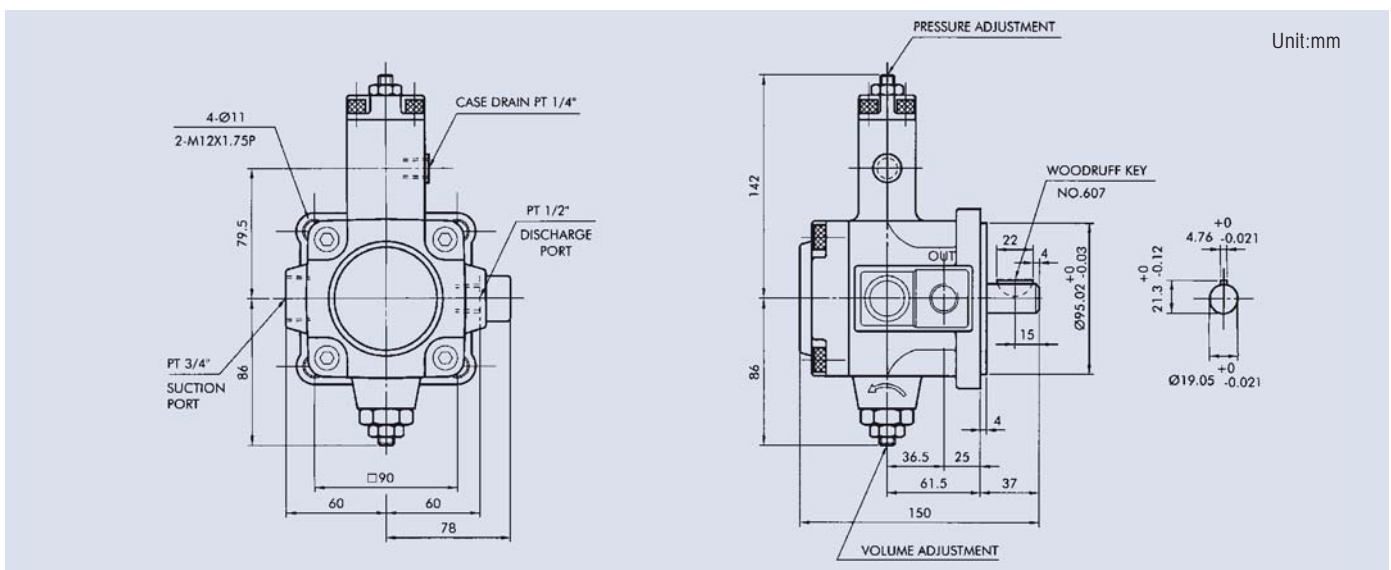

VARIABLE DISPLACEMENT VANE PUMP

Performance curves

A

VP-F8

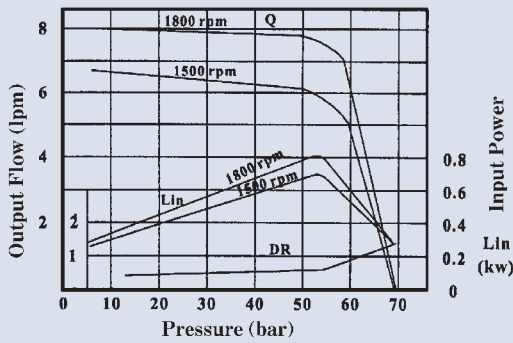

VP-F12

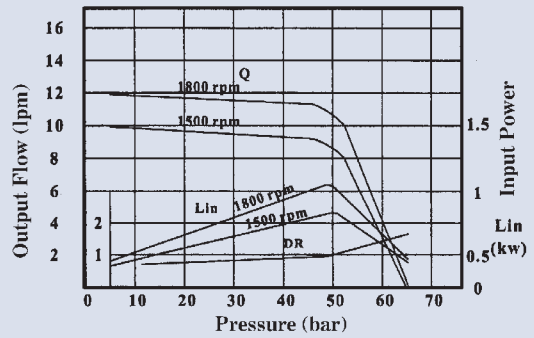

VP-F15

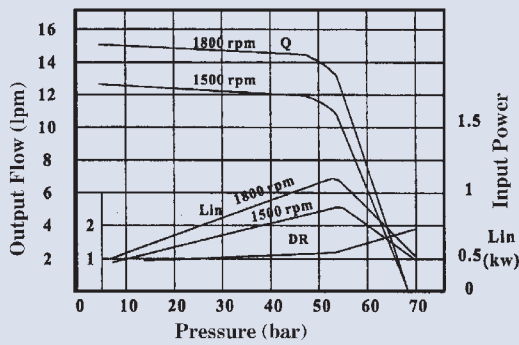

VP-F20

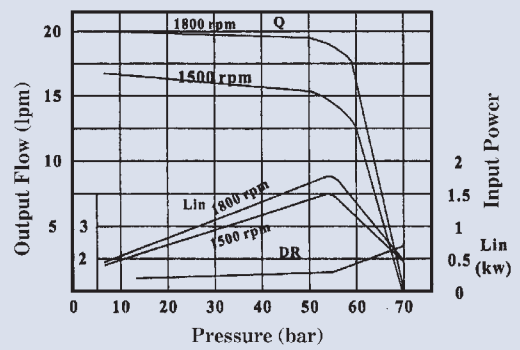

VP-F26

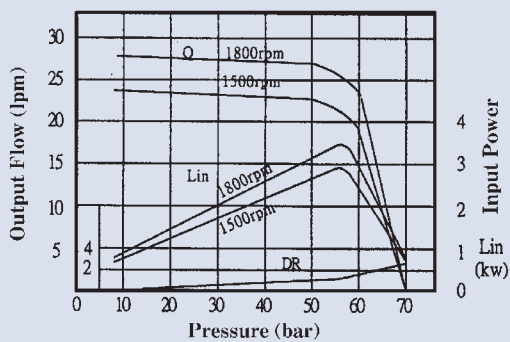

VP-F30

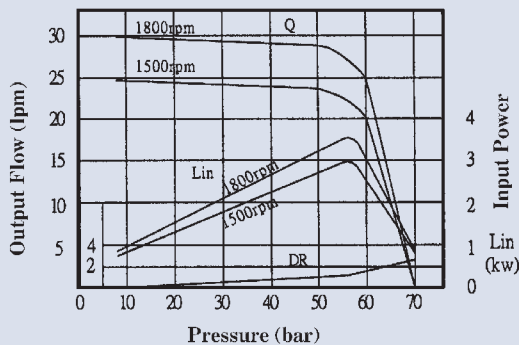

VP-F40

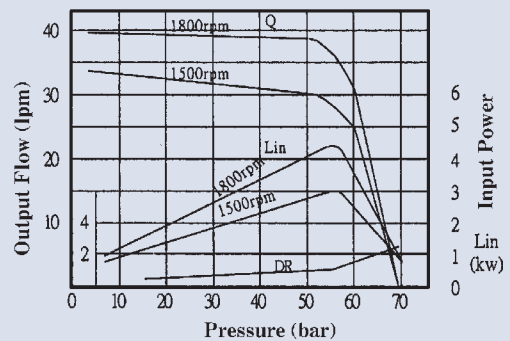

VARIABLE DISPLACEMENT VANE PUMP

VP-F8, 12, 15, 20 cross section drawing

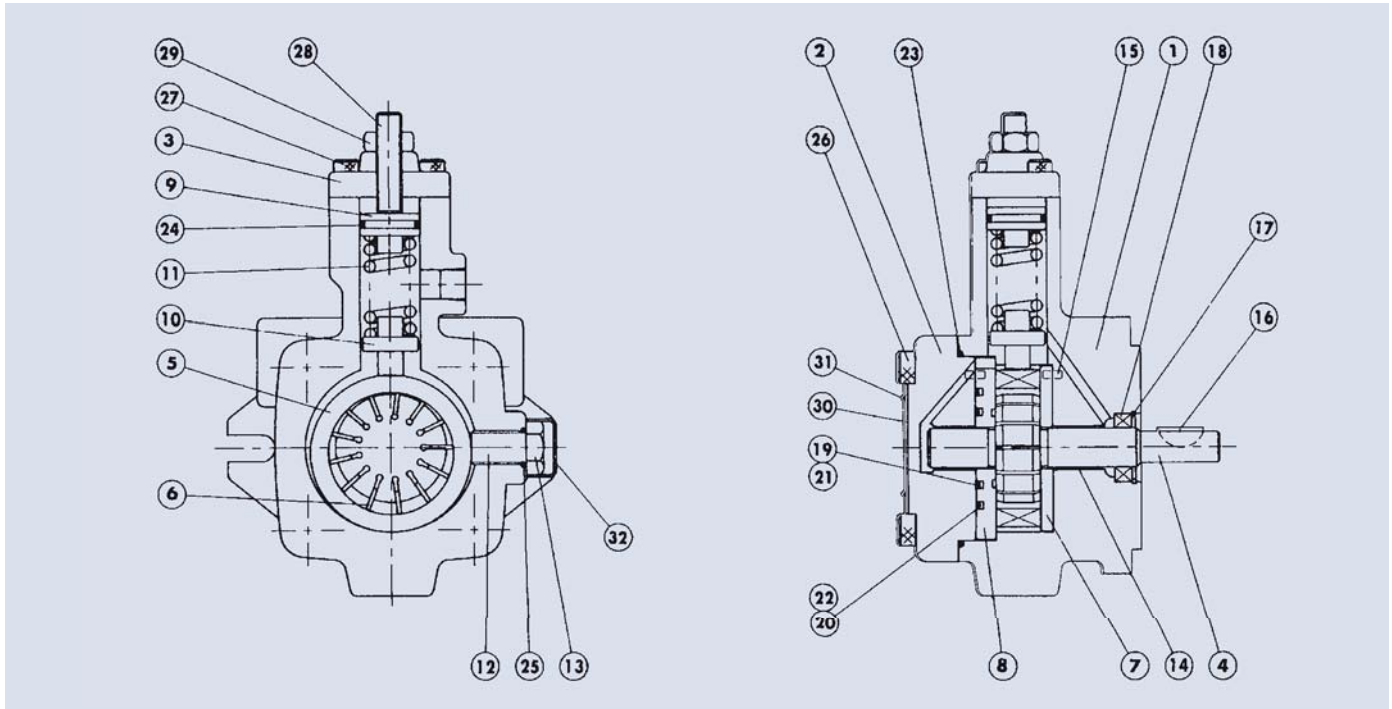

Parts list

Item No.	Description	Q'ty	Specification	Item No.	Description	Q'ty	Specification
1	Pump Body	1		17	Retainer Ring	1	R28
2	Back Cover	1		18	Shaft Seal	1	TC.V 16287
3	Cover	1		19	Endless Back-up ring	1	
4	Shaft	1		20	Endless Back-up ring	1	
5	Cam Ring	1		21	O-Ring	1	AS 568-023
6	Vanes	13		22	O-Ring	1	AS 568-031
7	Port Plate	1		23	O-Ring	1	1A-S75
8	Thrust Plate	1		24	O-Ring	1	1A-P20
9	Spring Retainer	1		25	O-Ring	1	1A-P12
10	Piston	1		26	Socket Head Cap Screws	4	M8×25×P1.25
11	Spring	1		27	Socket Head Cap Screws	2	M6×20×P1.0
12	Slide Screw	1		28	Socket Set Screws	1	M10×35×P1.5
13	Hex Nut	1		29	Hex Nut	1	M10×P1.5
14	Engine Bush	2	DD 1615	30	Name Plate	1	1
15	Pin	5	ø3×8	31	Fixing Screw	3	3
16	Woodruff Key	1	No. 405	32	Cap	1	1



VARIABLE DISPLACEMENT VANE PUMP

VP-F23, 26, 30, 40 cross section drawing

A

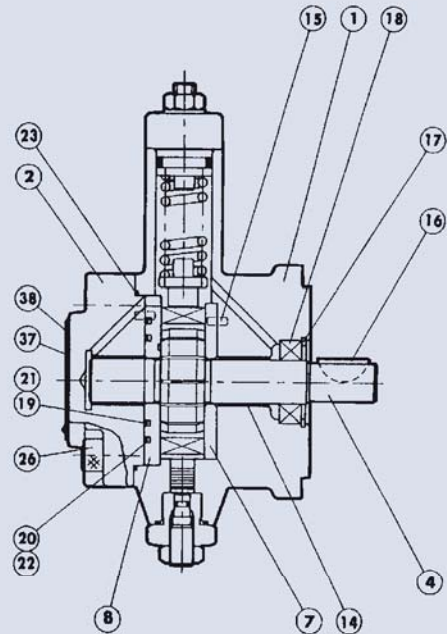
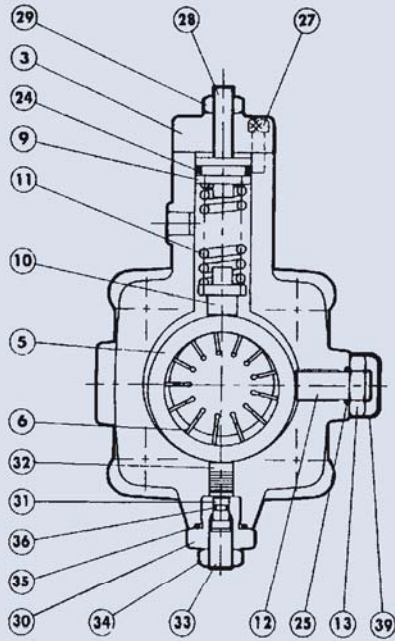

Parts list

Item No.	Description	Q'ty	Specification	Item No.	Description	Q'ty	Specification
1	Pump Body	1		21	O-Ring	1	AS 568-030
2	Back Cover	1		22	O-Ring	1	AS 568-035
3	Cover	1		23	O-Ring	1	1A-S85
4	Shaft	1		24	O-Ring	1	1A-P22A
5	Cam Ring	1		25	O-Ring	1	1A-P14
6	Vanes	13		26	Socket Head Cap Screws	4	M10×25×P1.5
7	Port Plate	1		27	Socket Head Cap Screws	2	M6×20×P1.0
8	Thrust Plate	1		28	Socket Set Screws	1	M10×40×P1.5
9	Spring Retainer	1		29	Hex Nut	1	M10×P1.5
10	Piston	1		30	Thrust Screw	1	
11	Spring	1		31	Piston	1	
12	Slide Screw	1		32	Piston	1	
13	Hex Nut	1	M16×P1.0	33	Socket Set Screw	1	M12×24×P1.75
14	Engine Bush	2	DD 2225	34	Hex Nut	1	M12×P1.75
15	Pin	5	4×10	35	O-Ring	1	1A-P20
16	Woodruff Key	1	No. 607	36	O-Ring	1	1A-P5
17	Retainer Ring	1	R42	37	Name Plate	1	
18	Shaft Seal	1	TCV 224211	38	Fixing Screw	3	
19	Endless Back-up ring	1		39	Cap	1	
20	Endless Back-up ring	1		40			

VARIABLE DISPLACEMENT DOUBLE VANE PUMP



DVP-F12+12 ,F15+15 ,F20+20

How to order

DVP - F 1515 - A 1A1

- | 1 | 2 | 3 | 4 | 5 |
|---|---|---|---|---|
| 1 | Variable double vane pump: weight: 9.5 kgs | | | |
| 2 | Flange mounting type | | | |
| 3 | Displacement | | | |
| 4 | Sharp cut-off type | | | |
| 5 | Pressure adjusting range 1: 3-20 bar 2: 15-55 bar 3: 30-70 bar
(As general rule low pressure pump is placed at the cover side and high pressure pump at the shaft side). | | | |

Dimensions

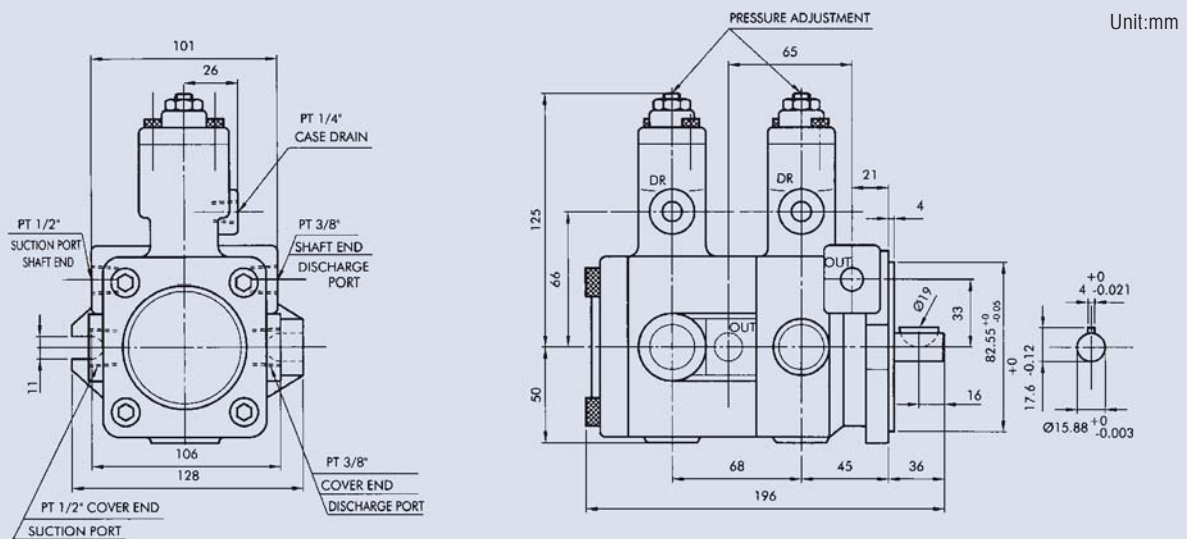

VARIABLE DISPLACEMENT DOUBLE VANE PUMP

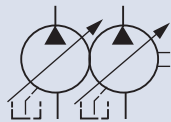

Symbol



DVP-F23+23, F26+26,
F30+30, F40+40

A

How to order

DVP - F 3030 - A 1A1

1 2 3 4 5

- 1 Variable double vane pump: weight: 16 kgs
- 2 Flange mounting type
- 3 Displacement
- 4 Sharp cut-off type
- 5 Pressure adjusting range 1: 3-20 bar 2: 15-55 bar 3: 30-70 bar
(As general rule low pressure pump is placed at the cover side and high pressure pump at the shaft side).

Dimensions

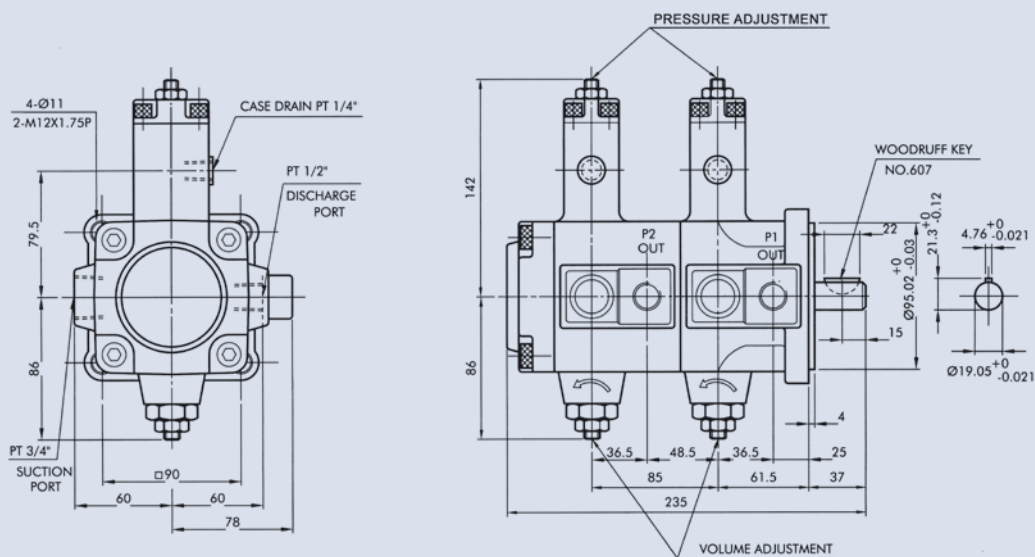

VARIABLE DISPLACEMENT VANE PUMP+GEAR PUMP

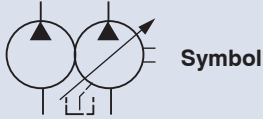

Symbol



VPG-F23 (26, 30, 40) + HGP-2A

How to order

VPG - F 30/3 - A 3

1 2 3 4 5 6

- | | |
|---|--|
| 1 | Variable vane pump+gear pump |
| 2 | Flange mounting type |
| 3 | Low pressure vane pump displacement: 23: 23 lpm (6 GPM) Weight: 10 kg 26: 26 lpm (6.8 GPM) Weight: 10 kg
30: 30 lpm (8 GPM) Weight: 10 kg 40: 40 lpm (10.5 GPM) Weight: 10 kg |
| 4 | Gear pump displacement: 3: 3 cc/rev (see page 129) |
| 5 | Sharp cut-off type |
| 6 | Pressure adjusting range 1: 3-20 bar 2: 15-55 bar 3: 30-70 bar |

Dimensions

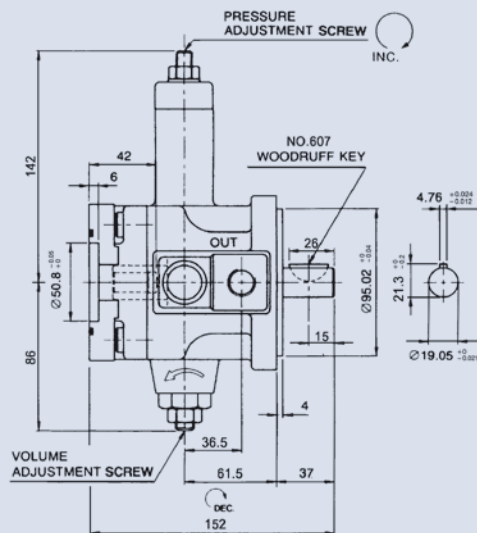
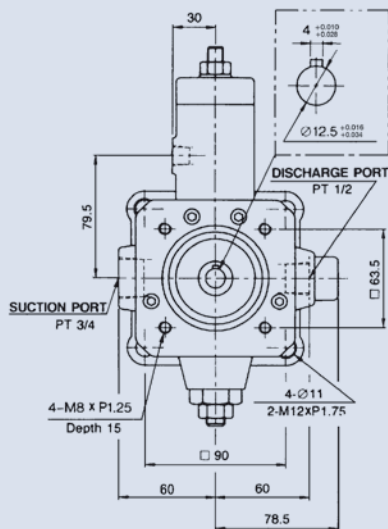

Unit:mm



HIGH PRESSURE VARIABLE DISPLACEMENT VANE PUMP

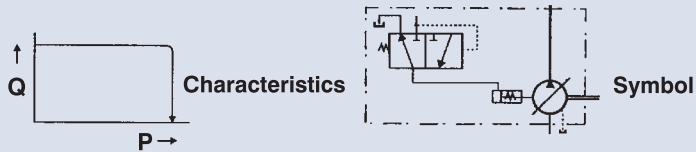

VP5-F20, 25, 30, 40, 54, 70, 86

A

How to order

VP5 - F 30 - A 5

- | 1 | 2 | 3 | 4 | 5 | |
|---|--|---|---|---|--|
| 1 | High pressure variable displacement single vane pump | | | | |
| 2 | Flange mounting type | | | | |
| 3 | Displacement | | | | |
| 4 | A: Sharp cut-off type | | | | |
| 5 | Pressure adjusting range 2: 15-35 bar 3: 20-70 bar 4: 50-105 bar 5: 70-140 bar | | | | |

Specifications

Model	No-Load Displacement lpm At 1800 rpm	Pressure Adj. Range (bar)	Rated Speed (rpm)		Max. Pressure (bar)	Weight (kg)
			Max.	Min.		
VP5-F20	20	2: 15-35 3: 20-70 4: 50-105 5: 70-140	1800	800	140	9.5
VP5-F25	25					9.5
VP5-F30	30					9.5
VP5-F40	40					9.5
VP5-F54	54					25
VP5-F70	70	25				
VP5-F86	86	25				

FEATURES:

1. High efficiency and high stability even on high pressure operation.
2. Vibration free with low noise level.
3. Sensitive responses and actions to on-off and changing loads.
4. Constant output on high pressure operation.
5. High operational efficiency with hores power saving.
6. Easier control on the adjustment of the pressure and oil flow.

Dimensions

Unit:mm

VP5-F20, 25, 30, 40

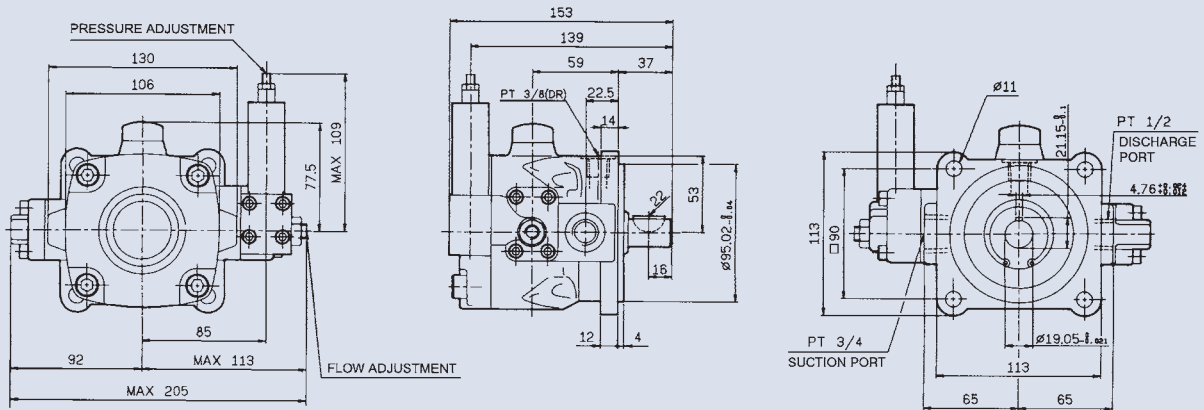

VP5-F54, 70, 86

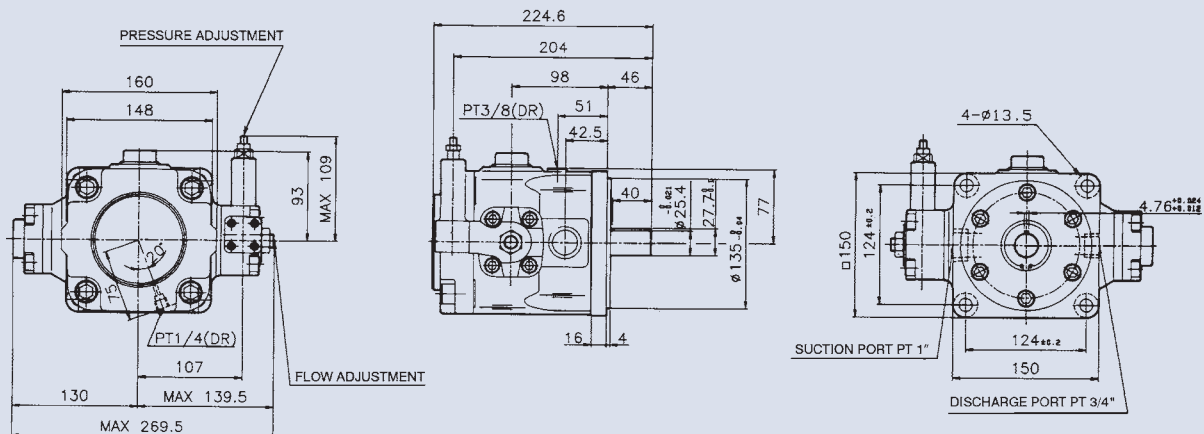

HIGH PRESSURE VARIABLE DISPLACEMENT VANE PUMP

Performance curves

A

VP5-F20

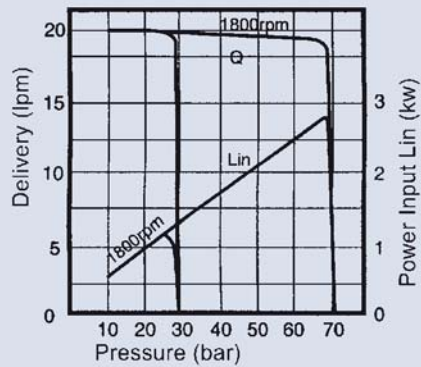

VP5-F40

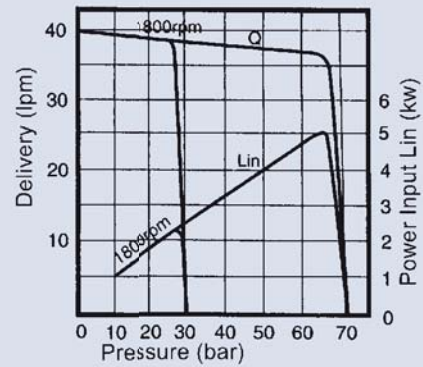

VP5-F25

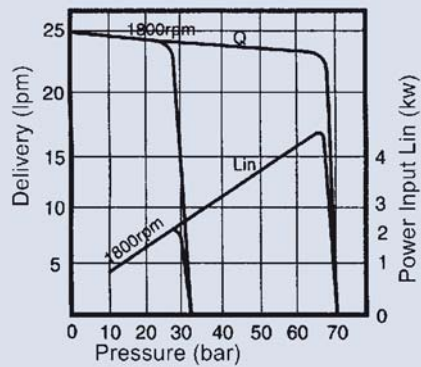

VP5-F54

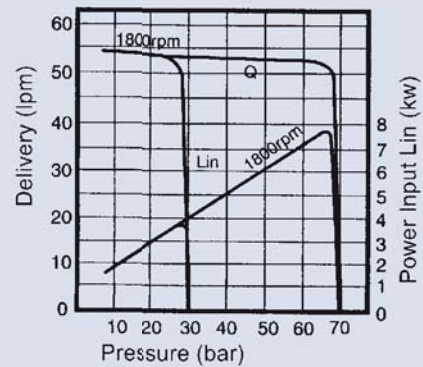

VP5-F30

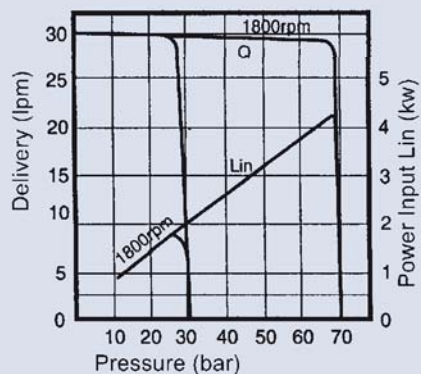

VP5-F70

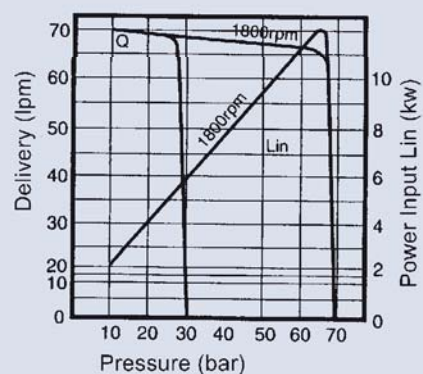

HIGH PRESSURE VARIABLE DISPLACEMENT VANE PUMP

VP5-F20, 25, 30, 40, 54, 70, 86 decomposition chart

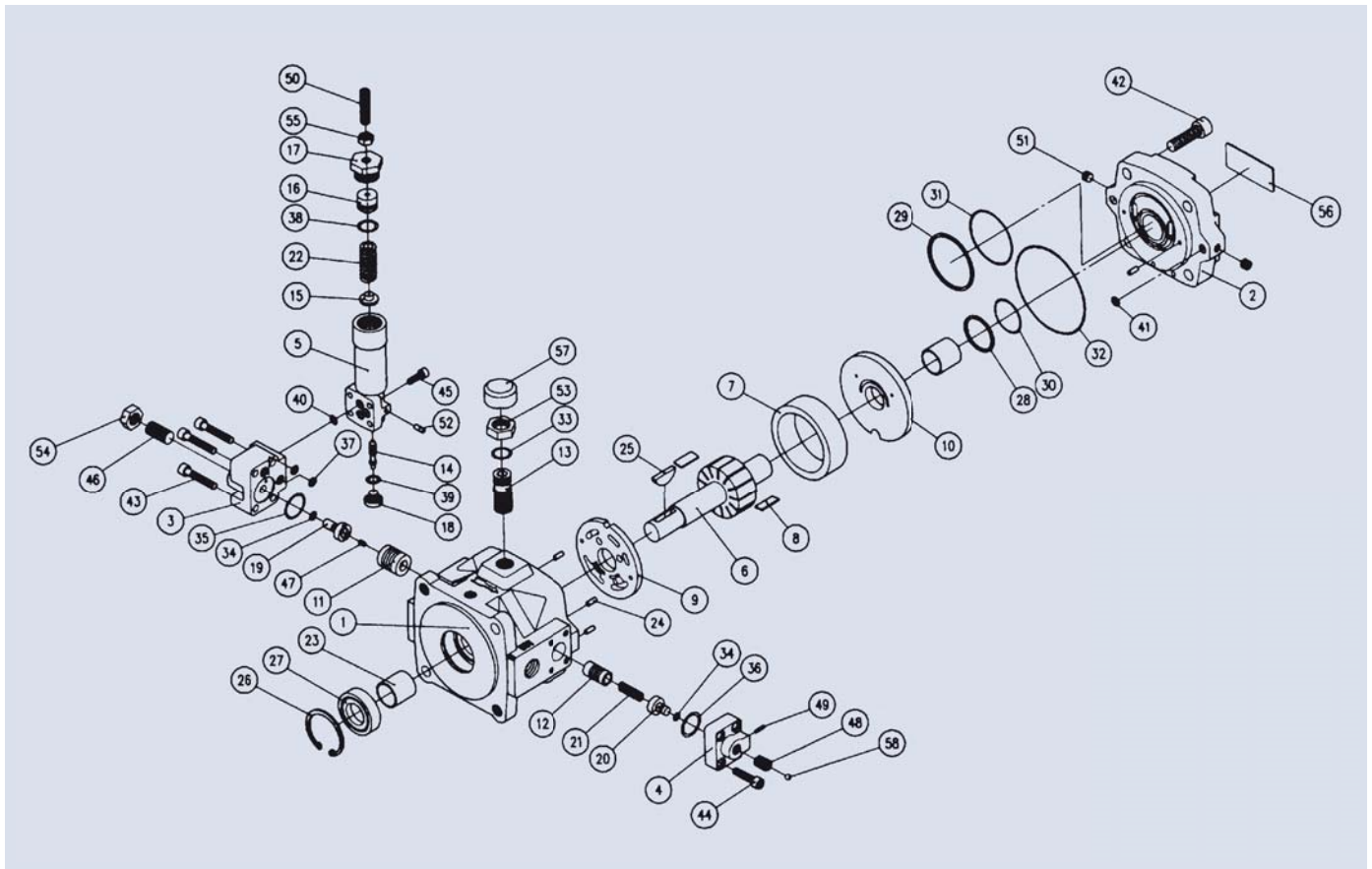

Parts list

Item No.	Description	Item No.	Description	Item No.	Description	Item No.	Description
1	Pump Body	16	Spring Retainer	31	O-Ring	46	Socket Set Screw
2	Back Cover	17	Screw	32	O-Ring	47	Socket Set Screw
3	Cover	18	plug	33	O-Ring	48	Socket Set Screw
4	Side Cover	19	Piston	34	O-Ring	49	Socket Set Screw
5	Body	20	Piston	35	O-Ring	50	Socket Set Screw
6	Shaft	21	Spring	36	O-Ring	51	Plug
7	Cam Ring	22	Spring	37	O-Ring	52	Plug
8	Vanes	23	Engine Bush	38	O-Ring	53	Hex Nut
9	Port Plate	24	Pin	39	O-Ring	54	Hex Nut
10	Thrust Plate	25	Woodruff Key	40	O-Ring	55	Hex Nut
11	Piston	26	Retainer Ring	41	O-Ring	56	Nameplate
12	Piston	27	Shaft Seal	42	Socket Head Cap Screw	57	Cap
13	Slide Screw	28	Endless Back-up ring	43	Socket Head Cap Screw	58	Plug
14	Spool	29	Endless Back-up ring	44	Socket Head Cap Screw	59	
15	Holder	30	O-Ring	45	Socket Head Cap Screw	60	

HIGH PRESSURE VARIABLE DISPLACEMENT DOUBLE VANE PUMP

A

How to order

VP5 - F - 1-2 - 30 - 70 - A - 2 - A - 2

1 2 3 4 5 6 7 8 9

1	Model
2	Flange mounting type
3	Series number 1: 20, 25, 30, 40 lpm 2: 54, 70, 86 lpm
4	Cover side pump delivery lpm
5	Shaft end pump delivery lpm
6	Cover side pump control type A: Sharp cut-off type
7	Cover side pump pressure adjusting range 2: 15-35 bar 3: 20-70 bar 4: 50-105 bar 5: 70-140 bar
8	Shaft end pump control type A: Sharp cut-off type
9	Shaft end pump pressure adjusting range 2: 15-35 bar 3: 20-70 bar 4: 50-105 bar 5: 70-140 bar

Dimensions

VP5-F-11

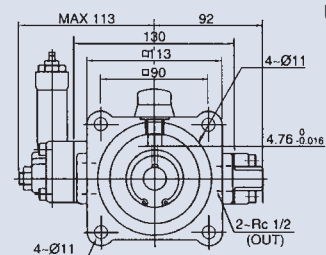
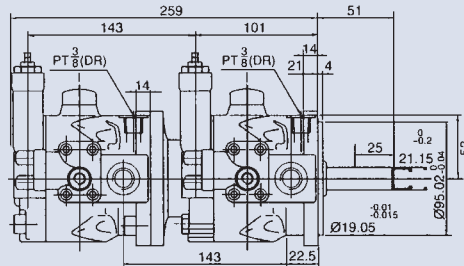
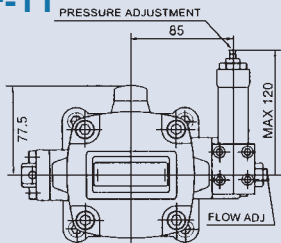

VP5-F-12

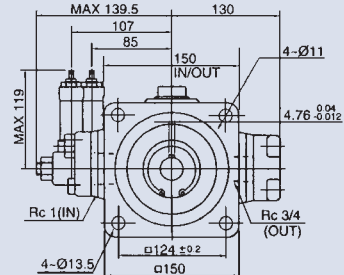
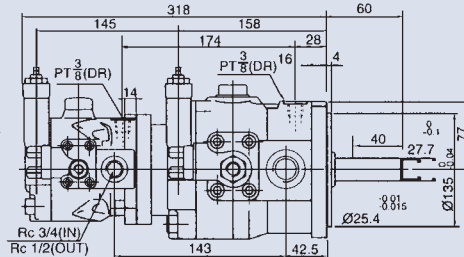
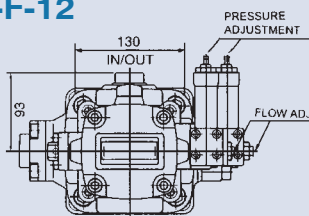

VP5-F-22

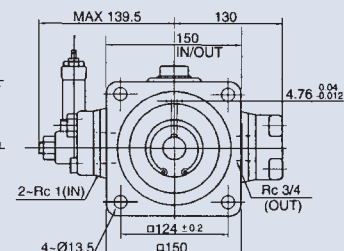
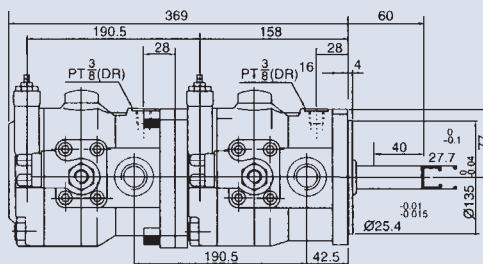
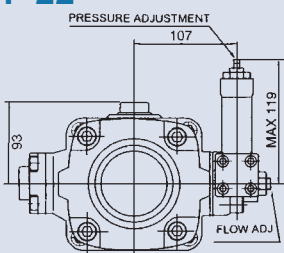

V SERIES AXIAL PISTON PUMP

Control Types

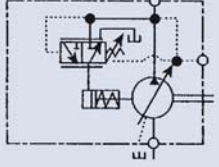
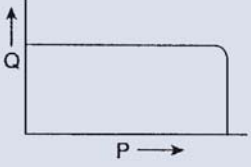
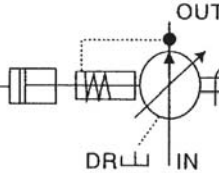
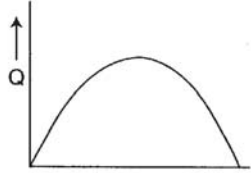
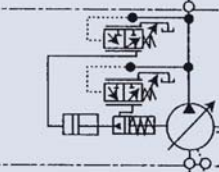
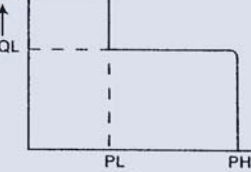
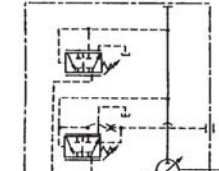
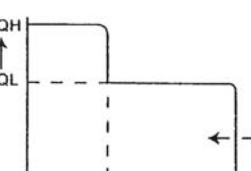
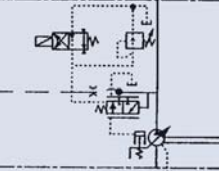
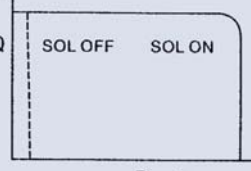
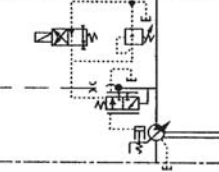
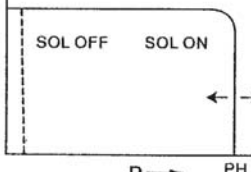
Control Types	JIS Symbols	Characteristics	Feature
A: Pressure Compensator Control			<ol style="list-style-type: none"> 1. When system pressure increase and reach preset pressure the flow decrease automatically and pressure maintain without changing. 2. Power and pressure can be adjusted manually.
B: Multi-stage Flow & Single stage Pressure Control Type (With Cylinder)			<ol style="list-style-type: none"> 1. Flow can be adjusted from 0 to maximum and pressure can be maintaining at preset pressure. 2. Absorbing impact and vibration which are produced by up and down motions of actuators. It is suitable for lifting equipment etc.
C: 2 stage Pressure & Flow Control Type			<ol style="list-style-type: none"> 1. Low consumption electric motor can be selected to save energy because of the functions of high flow at low pressure and low flow at high pressure. 2. When pressure increase and reach preset pressure "PH", flow is reduced to "QL". 3. Pressure "PH" "PL", and Flow "QH" "QL" can be adjusted optionally. 4. It is applied to actuators requiring long unloaded or short loaded strokes. Speedy and horsepower efficient.
CG: 2 stage remote Pressure & Flow Control Type			<ol style="list-style-type: none"> 1. The same function of "C" control type. 2. The pressure and the range can be adjusted remotely by the integrated remote pressure control valve. 3. Proportional Electro-hydraulic pressure control can be applied with HYDROME proportional valve.
D: Solenoid Controlled Pressure Compensating Type with Unloading Device			<ol style="list-style-type: none"> 1. Same as type A and unloading function added. 2. It is applied to systems requiring long term unloading operation. 3. When solenoid is turned off, pump operation under unloading condition maintains low noise level and oil heat generation.
DG: Solenoid Controlled Pressure Compensating Type with Unloading & Remote Device			<ol style="list-style-type: none"> 1. The same function of "C" control type. 2. The pressure and the range can be adjusted remotely by the integrated remote pressure control valve. 3. Proportional Electro-hydraulic pressure control can be applied with HYDROME proportional valve.

V SERIES AXIAL PISTON PUMP

Control Types

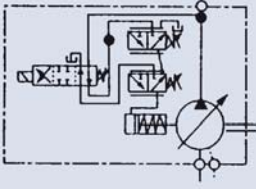
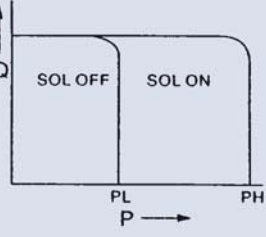
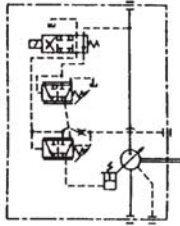
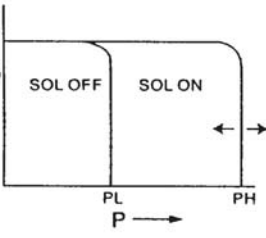
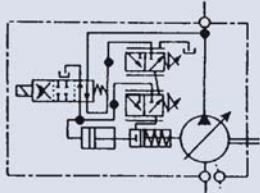
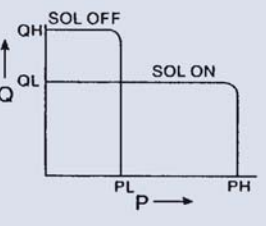
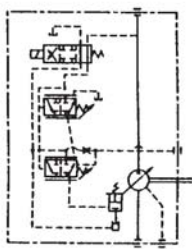
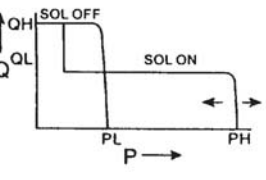
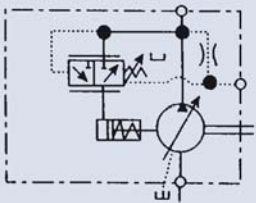
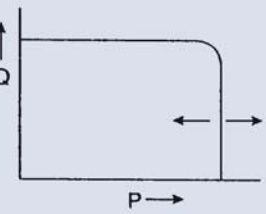
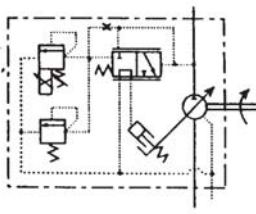
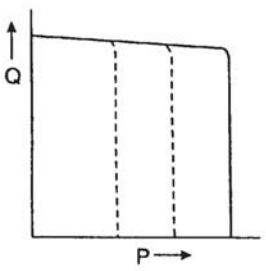
Control Types	JIS Symbols	Characteristics	Feature
E: Dual Pressure Control			<ol style="list-style-type: none"> 1. Preset high and low pressure can be controlled by switching directions of solenoid control valves. 2. This type is applied to actuators requiring 2 stage pressures with single speed. 3. One of "PL" and "PH" can be optionally be high pressure.
EG: Dual & Remote Pressure Control			<ol style="list-style-type: none"> 1. The same function of "E" control type. 2. The pressure and the range can be adjusted remotely by the integrated remote pressure control valve. 3. Proportional Electro-hydraulic pressure control can be applied with HYDROME proportional valve.
F: 2 flow-2 pressure p.c. by solenoid operated valve			<ol style="list-style-type: none"> 1. Actuators can be shifted slowly (high pressure low flow) and quickly (low pressure high flow) by switching directions of solenoid control valve. When solenoid valve turns on, pressure increase to "PH", and flow decrease to "QL". 2. Pressure "PL", "PH" and flow "QL", "QH" can be adjusted optionally. 3. This type is applied to actuator requiring operations of shift speed from high to low or low to high.
FG: 2 flow-2 pressure p.c. by solenoid operated & remote valve			<ol style="list-style-type: none"> 1. The same function of "F" control type. 2. The pressure and the range can be adjusted remotely by the integrated remote pressure control valve. 3. Proportional Electro-hydraulic pressure control can be applied with HYDROME proportional valve.
G: Remote pressure compensator control			<ol style="list-style-type: none"> 1. The same function of "A" control type. 2. Pressure can be adjusted remotely by the integrated remote pressure control valve.
GJ: Proportional Pressure with interface			<ol style="list-style-type: none"> 1. Same as Type "GM" and proportional valve added. 2. The proportional valve is installed on the NG 6 interface to reach Proportional Electro-hydraulic control to save energy.



V SERIES AXIAL PISTON PUMP

Control Types

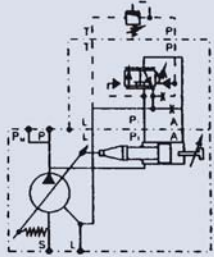
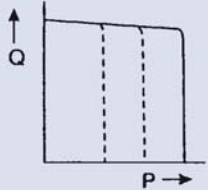
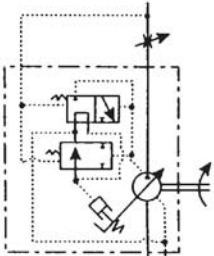
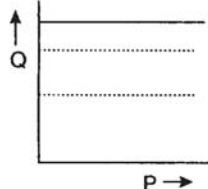
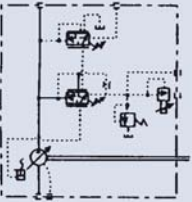
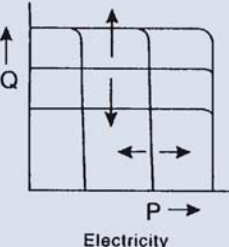
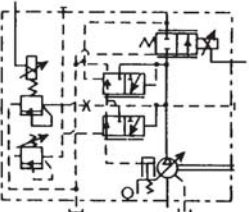
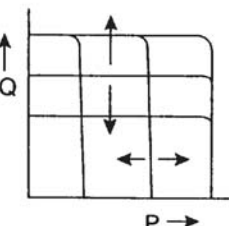
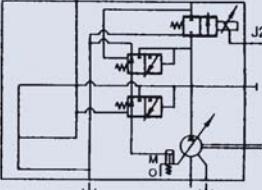
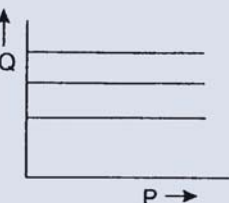
Control Types	JIS Symbols	Characteristics	Feature
GM: Remote Interface (Not include pilot valve)			<ol style="list-style-type: none"> 1. GM control with a NG6 interface, supply an installation for pilot valve to prove the operating pressure. The pressure setting can be set directly from the control panel of the machine. 2. The remote pressure compensator responds faster and offers more stable pressure. 3. The adjustment can also be manual or proportional pressure control.
HL: Load Sensing Compensator			<ol style="list-style-type: none"> 1. The pump outlet can be controlled by the setting pressure value of flow control valve. An ideal energy conservation system can be configured by combining the proportional directional control. 2. When setting pressure value, flow is changed depending on throttle valve. The sensing flow feedback function can reach to low oil heat generation and saving energy.
HJ: Load Sensing & Proportional Electro-hydraulic Pilot Relief Valve			<ol style="list-style-type: none"> 1. Same as Type "HL" and proportional pressure function added. 2. Supplied with proportional Electro-hydraulic pilot relief valve can reach to horse-saving and energy-saving.
HK: Proportional Electro-hydraulic Load Sensing Type			<ol style="list-style-type: none"> 1. HK type supplies the system pressure and flow depending on the proportional pressure and flow, voltage, and load value to save the energy. When in waiting circle, the outlet displacement and horse power loss are colse to zero. When pressure reaches to preset value, the flow decrease to the min., and the pressure is constant to reach low oil heat generation and energy loss. 2. HK type can save 30%~50% energy compare to vane pump and gear pump+PQ valve. It is an energy-saving and environmental design.
HQ: Load-sensing Proportional Flow control			<ol style="list-style-type: none"> 1. Same as Type "HL" and proportional flow function added. 2. The proportional flow control allows the adjustment of the pumps output flow with an electrical input signal. Supplied and adjusted the displacement by the electronic control module.

V SERIES AXIAL PISTON PUMP

Performance curves

MEASURING CONDITIONS

ROOM TEMPERATURE: $20 \pm 2^\circ\text{C}$

SPEED OF ROTATION: 1800 rpm

OIL: ISO VG 32-68

OIL CAPACITY: 40 lpm

ADOPTS SEALED CIRCUIT: 70 bar

ADJUST PRESSURE: 35 bar

V15, 18 Series

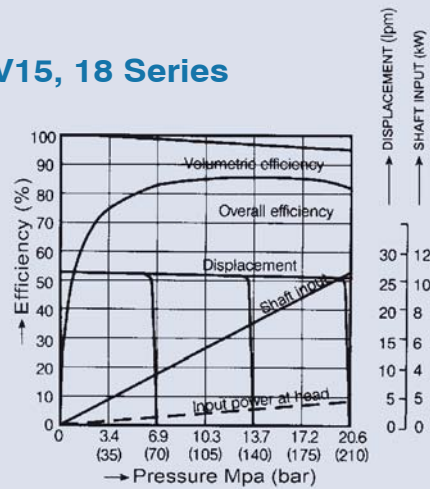

V23, 25 Series

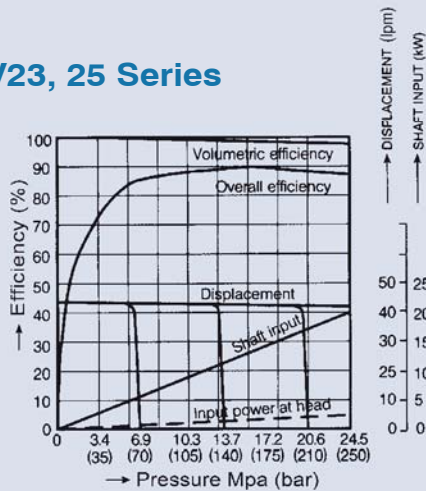

V38, 42 Series

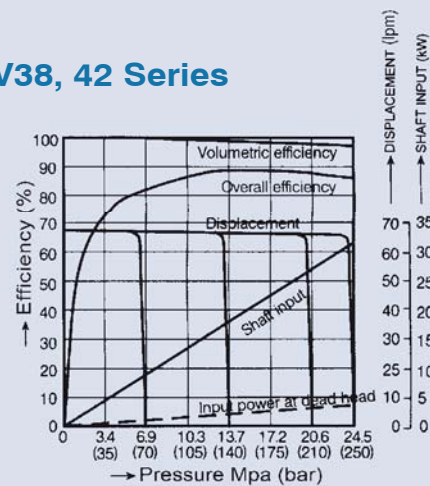

V50 Series

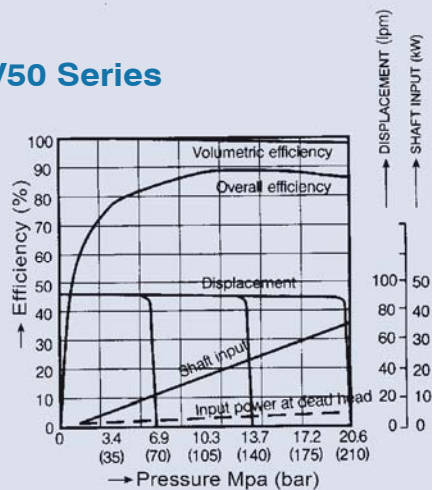

V70 Series

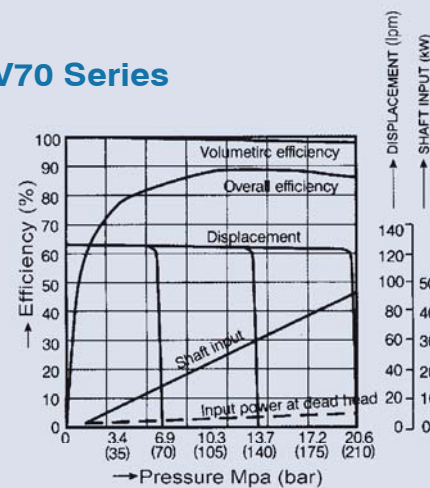

V SERIES AXIAL PISTON PUMP

Performance curves

B

V15, 18

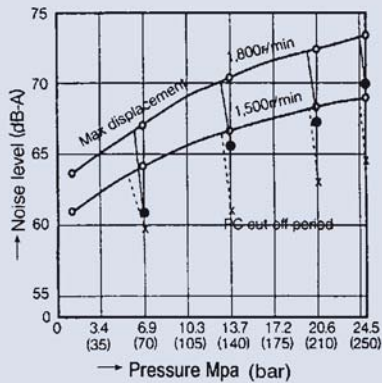

V23, 25

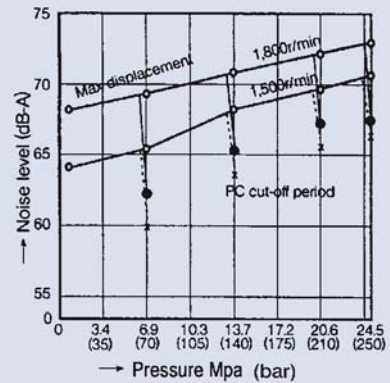

V38, 42

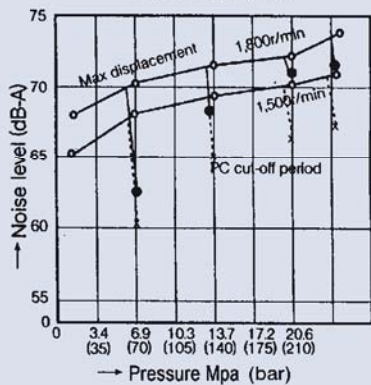

V50, 70

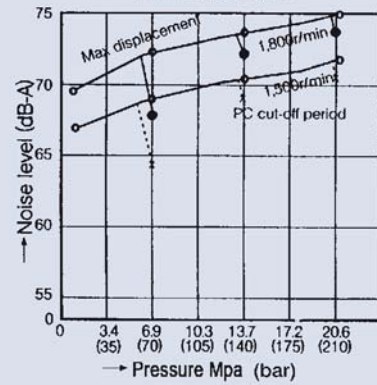

V15, 18

Drain volume characteristic

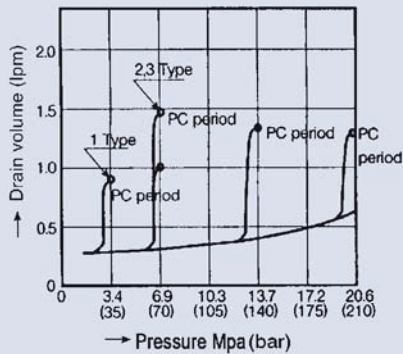

V23, 25

Drain volume characteristic

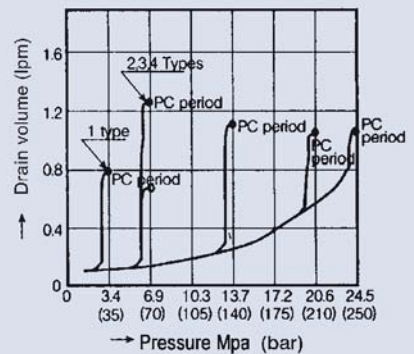

V38, 42

Drain volume characteristic

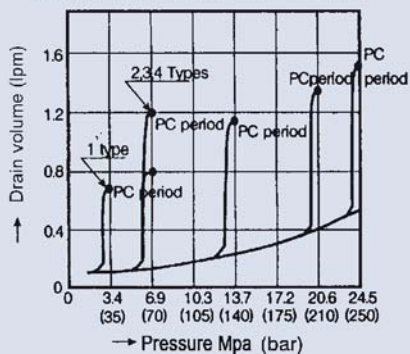

V50, 70

Drain volume characteristic

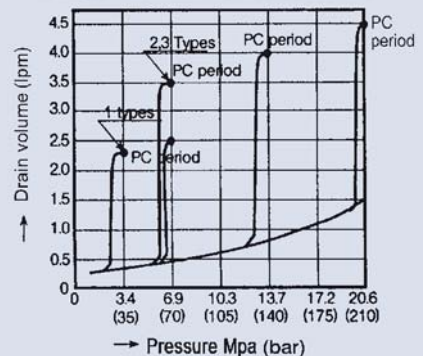

V SERIES AXIAL PISTON PUMP

Dimensions

V15A, V18A Pressure Compensator

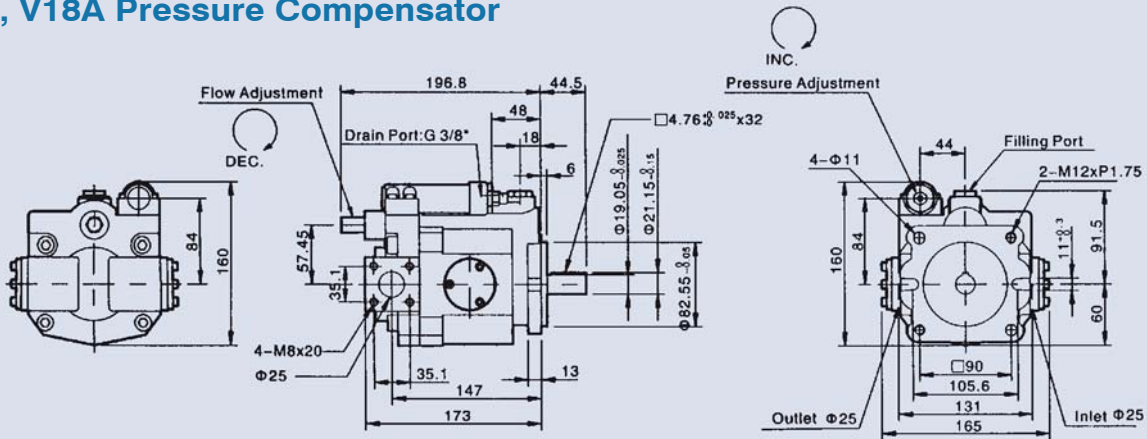

V15A, V18A Pressure Compensator (SAE A 2 bolt)

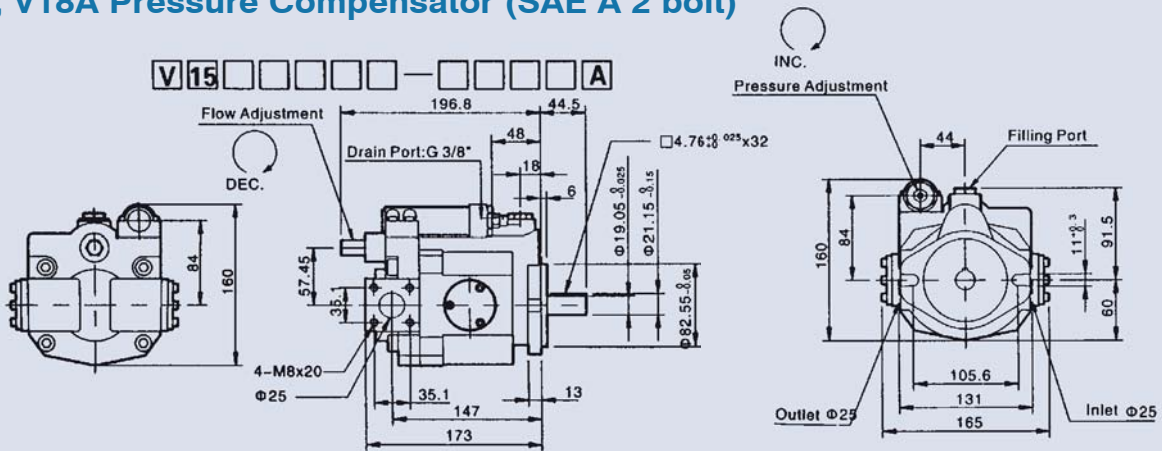

V15B, V18B Multi-stage Flow & Single-stage Pressure Compensator Control (With cylinder)

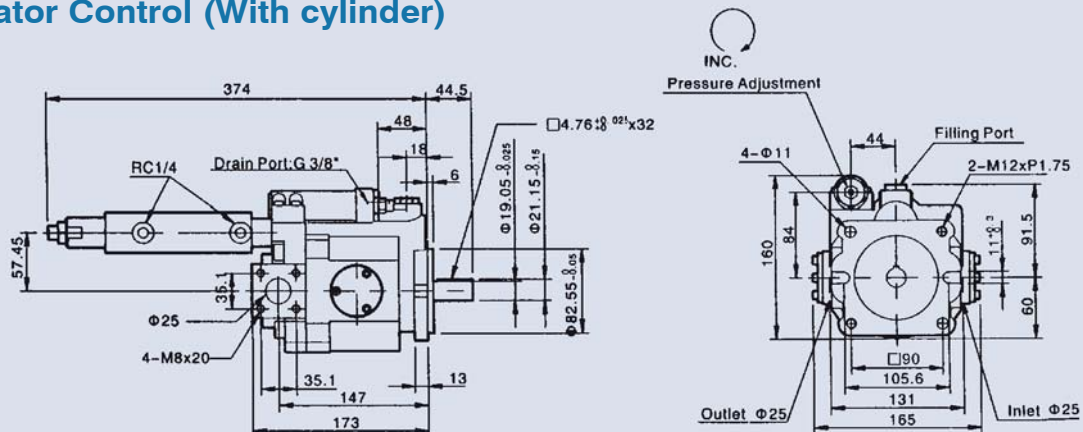

V SERIES AXIAL PISTON PUMP

Dimensions

V15C, V18C 2-stage Pressure & Flow Control Type

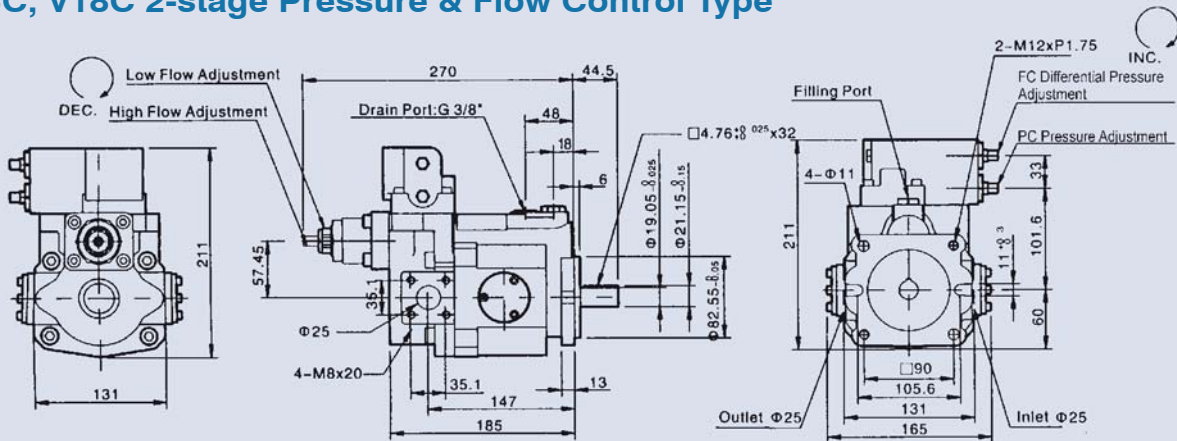

V15CG, V18CG 2-stage Pressure & Flow Control Type with Remote

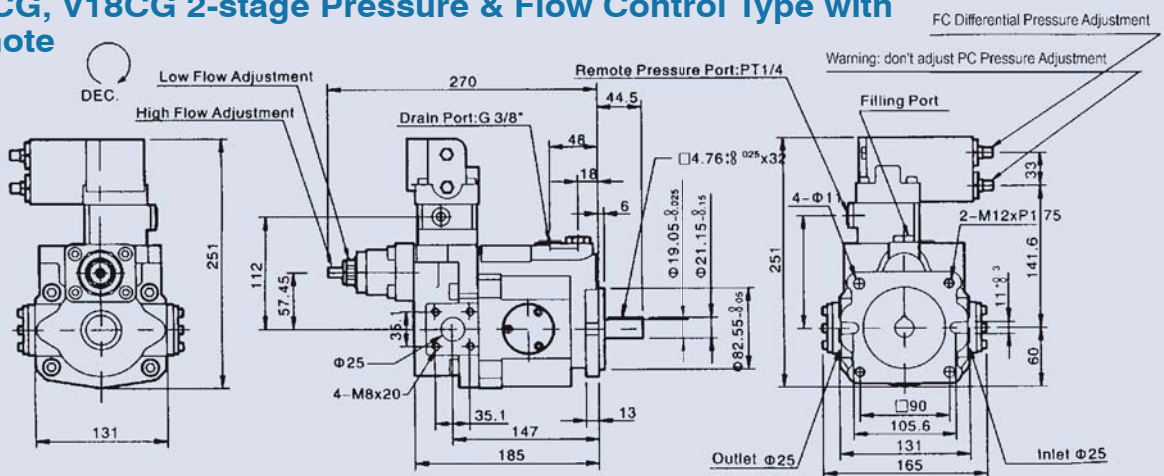

V15D, V18D Solenoid Controlled Pressure Compensating Type with Unloading Device

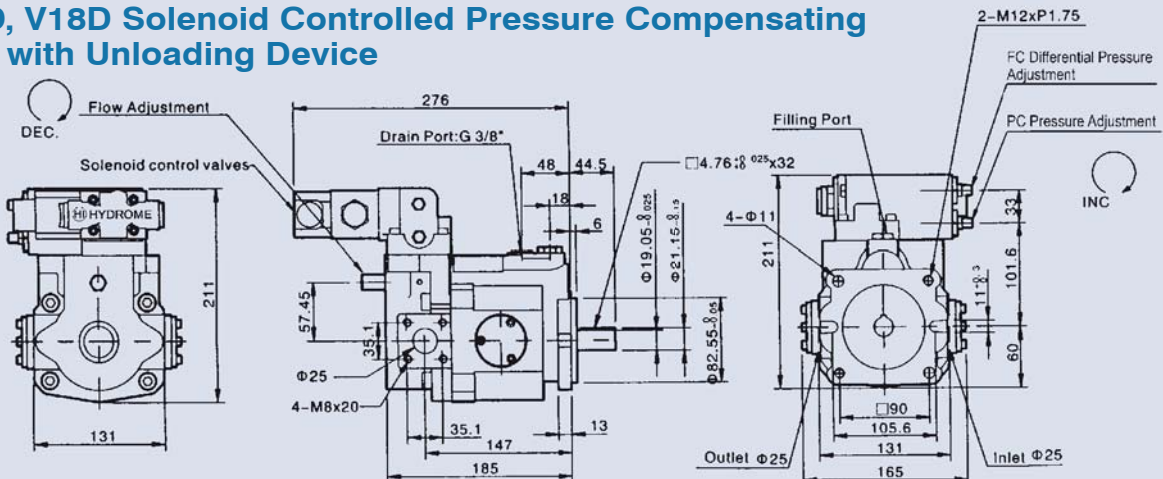

V SERIES AXIAL PISTON PUMP

Dimensions

V15F, V18F 2 Flow-2 Pressure Control by Solenoid Operated Valve

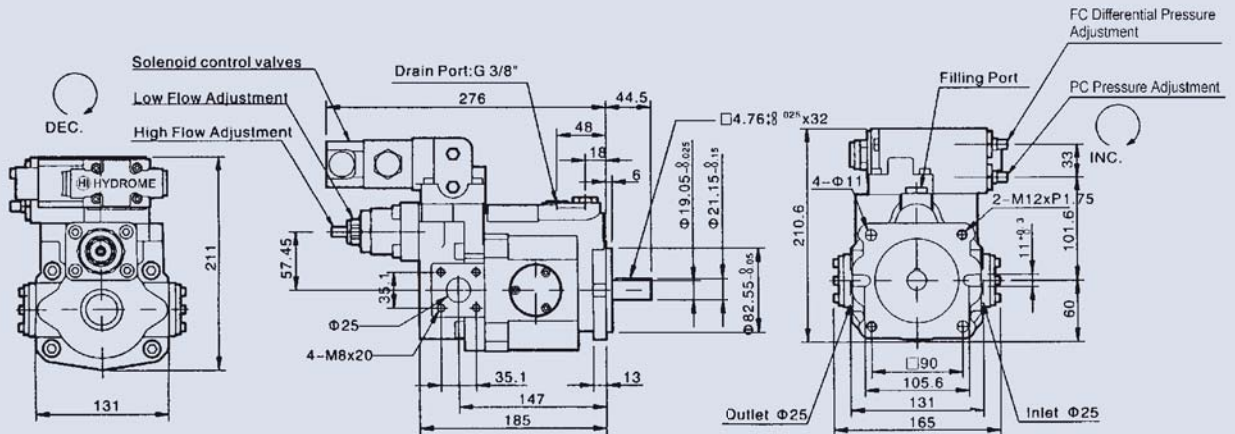

V15FG, V18FG 2 Flow-2 Pressure Control by Solenoid Operated & Remote Valve

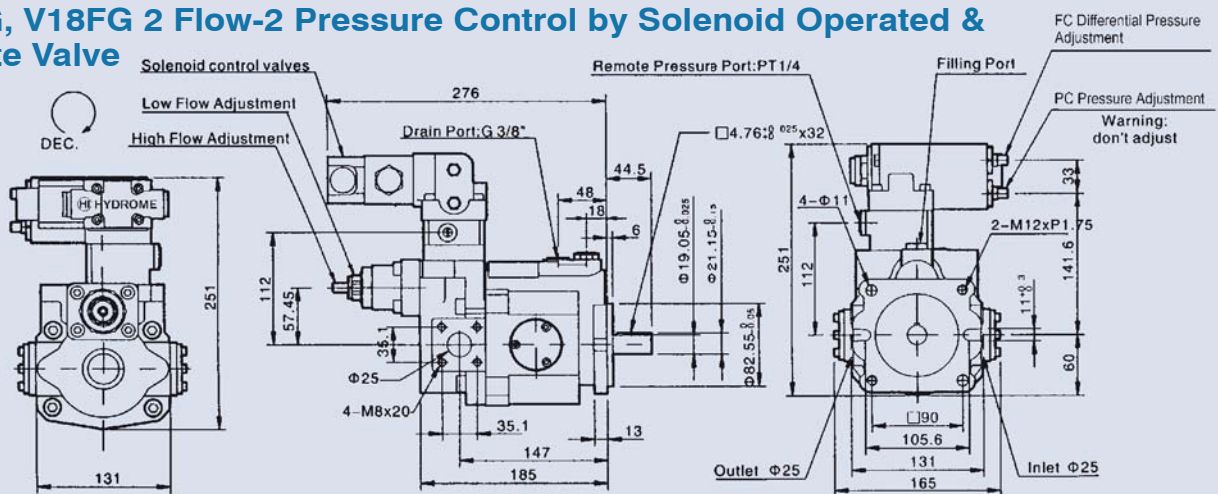

V15G, V18G Remoted Pressure Compensator Control

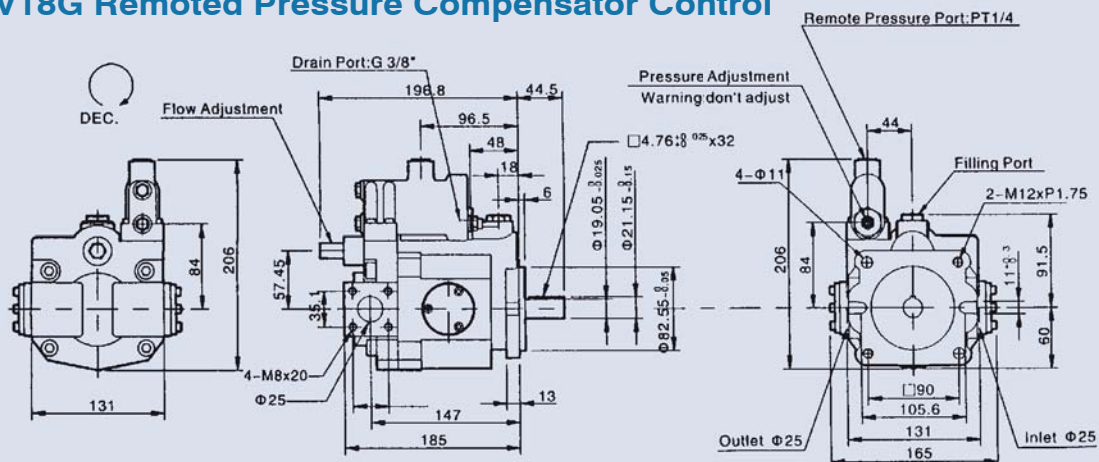

V SERIES AXIAL PISTON PUMP

Dimensions

V15GJ, V18GJ Proportional Pressure with Interface

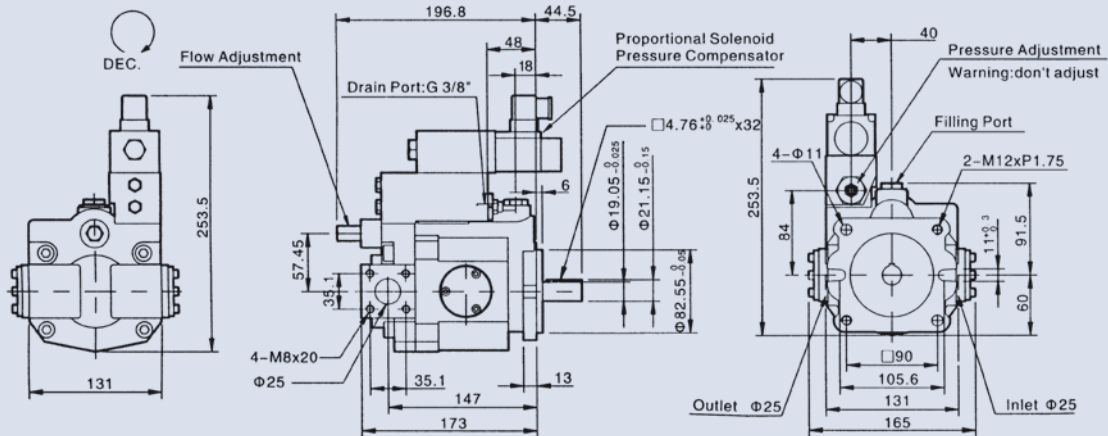

V15GM, V18GM Remote Interface (Not include valve)

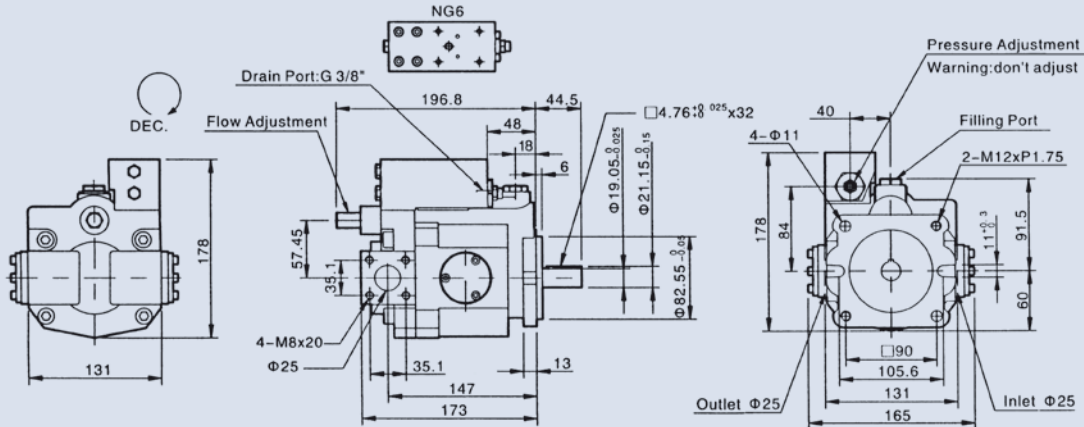

V15HL, V18HL Load-sensing Compensator

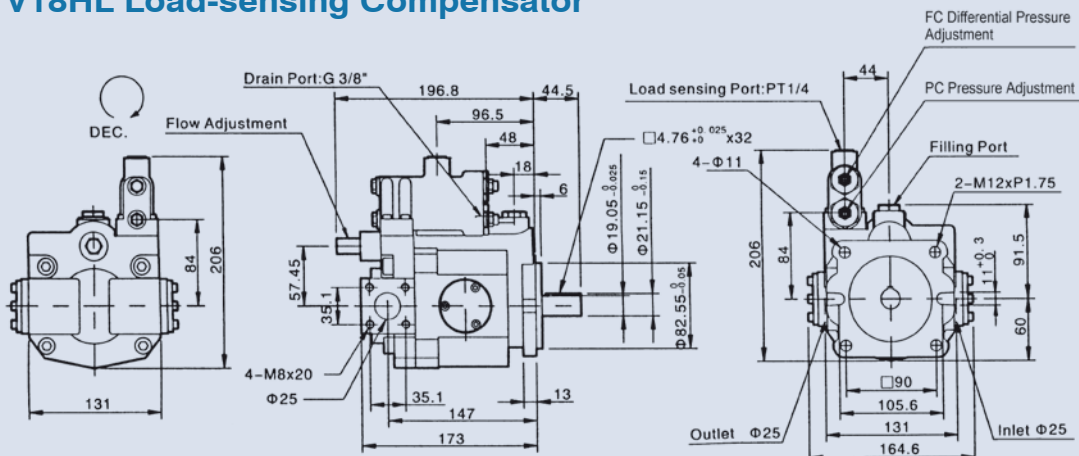

V SERIES AXIAL PISTON PUMP

Dimensions

V15, V18 Prepared for Thru Drive (SAE AA ϕ 50.8)

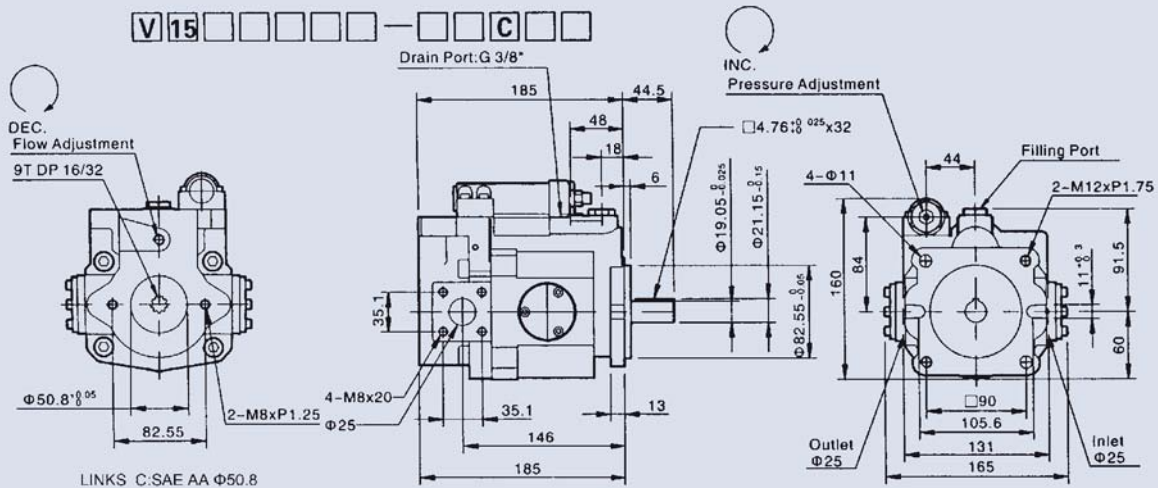

Type	A	B	C	CG	D	DG	E	EG	F	FG	G	GJ	GM	HL	HK	HQ
	O				O	O	O	O			O	O	O	O	O	O

Thru Drive Option

V15, V18 Prepared for Thru Drive (SAE A ϕ 82.55)

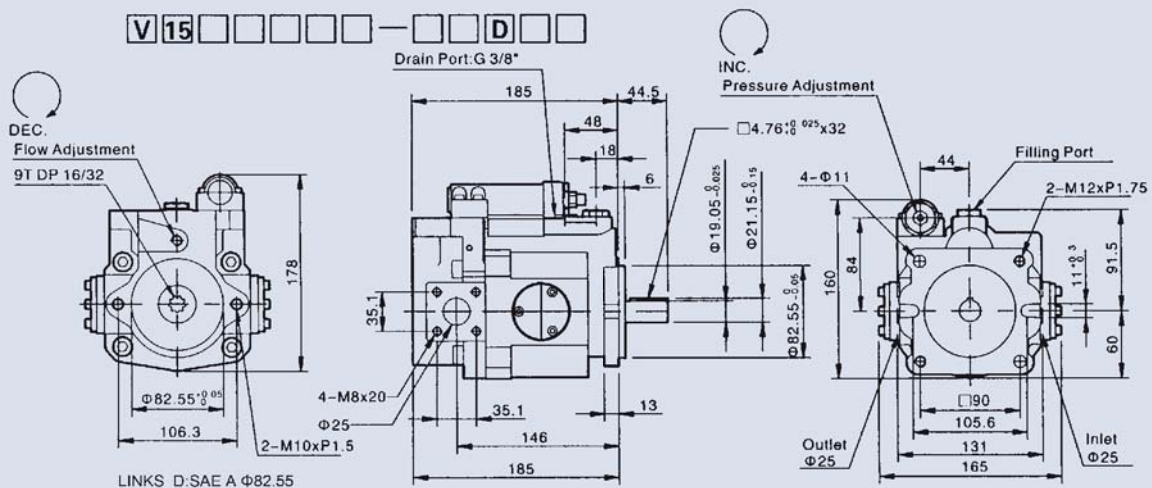

Type	A	B	C	CG	D	DG	E	EG	F	FG	G	GJ	GM	HL	HK	HQ
	O				O	O	O	O			O	O	O	O	O	

Thru Drive Option

V SERIES AXIAL PISTON PUMP

Dimensions

V23CG, V25CG 2-stage Pressure & Flow Control Type with Remote

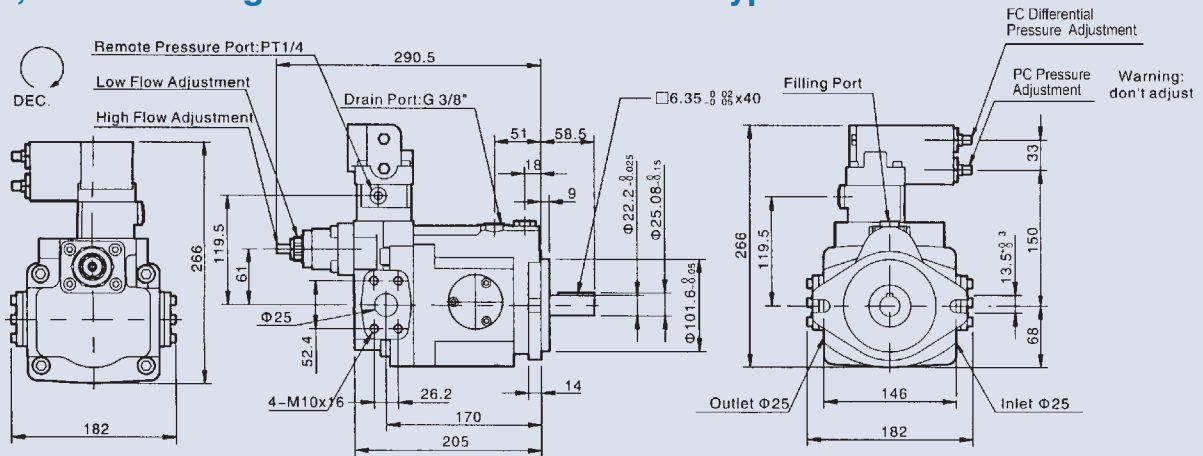

V23D, V25D Solenoid Controlled Pressure Compensating Type with Unloading Device

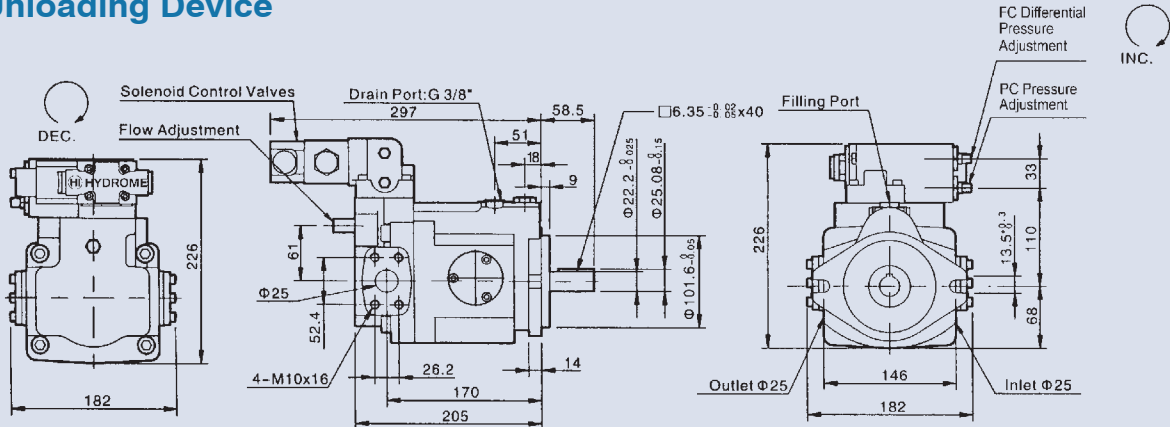

V23DG, V25DG Solenoid Controlled Pressure Compensating Type with Unloading Device & Remote

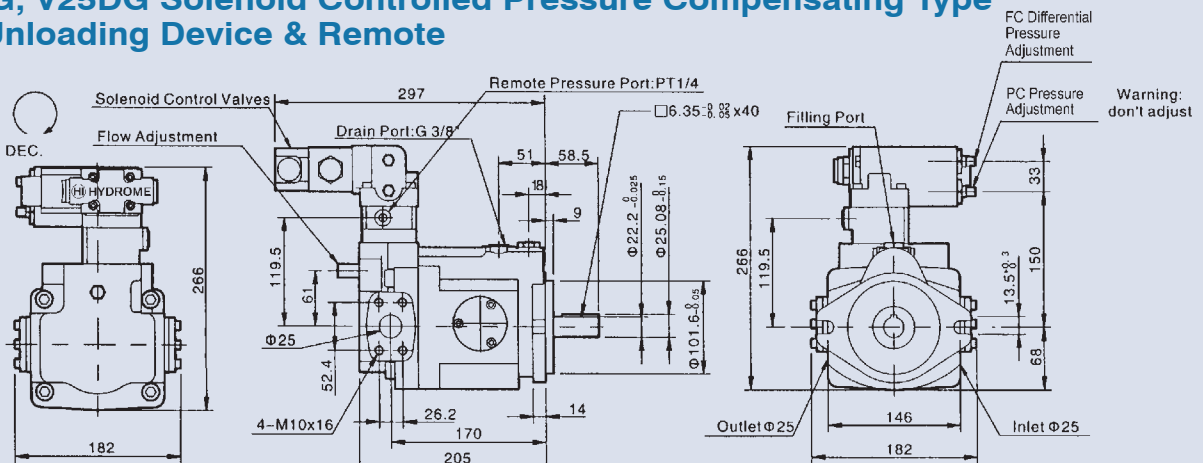

V SERIES AXIAL PISTON PUMP

Dimensions

V23E, V25E Dual Pressure Control

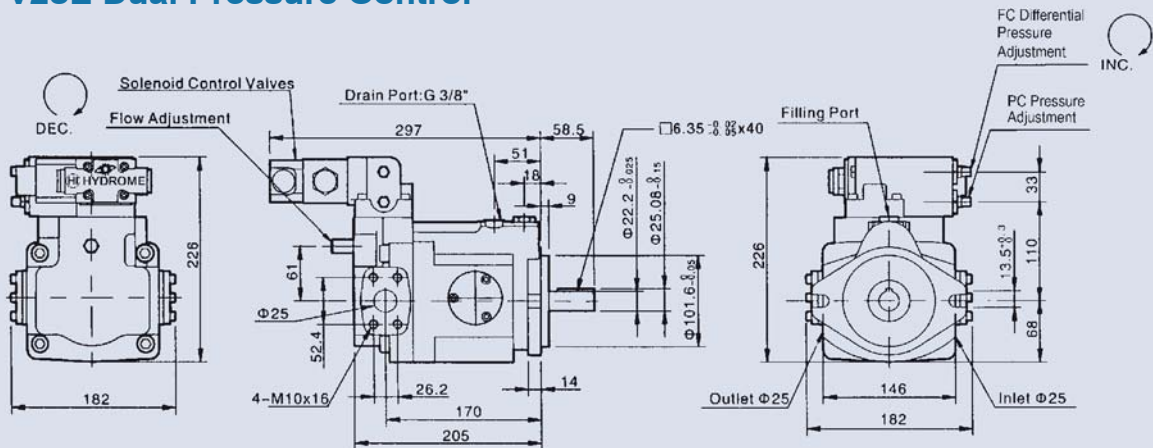

V23EG, V25EG Dual & Remote Pressure Control

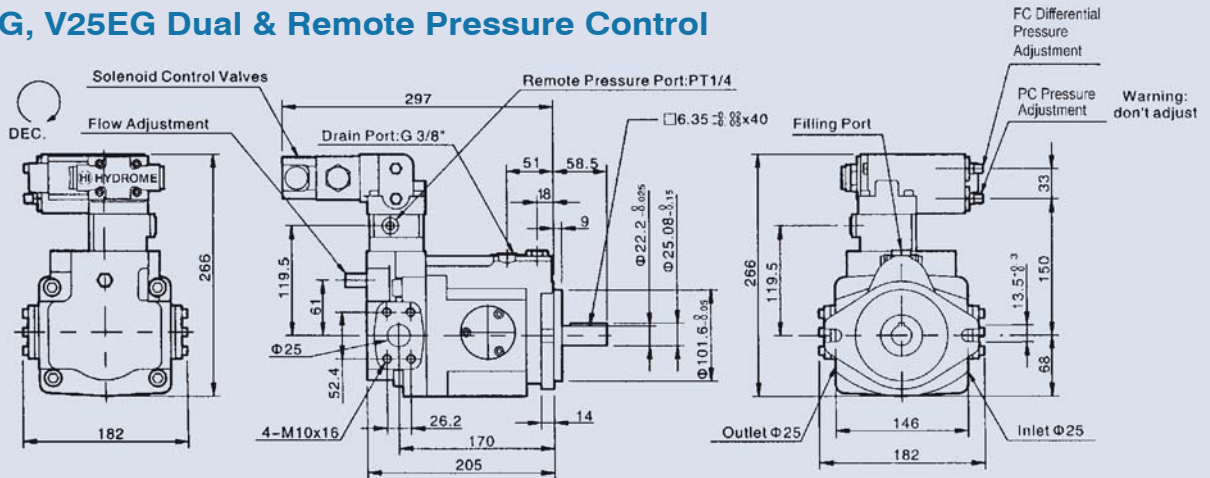

V23F, V25F 2 Flow-2 Pressure Control by Solenoid Operated Valve

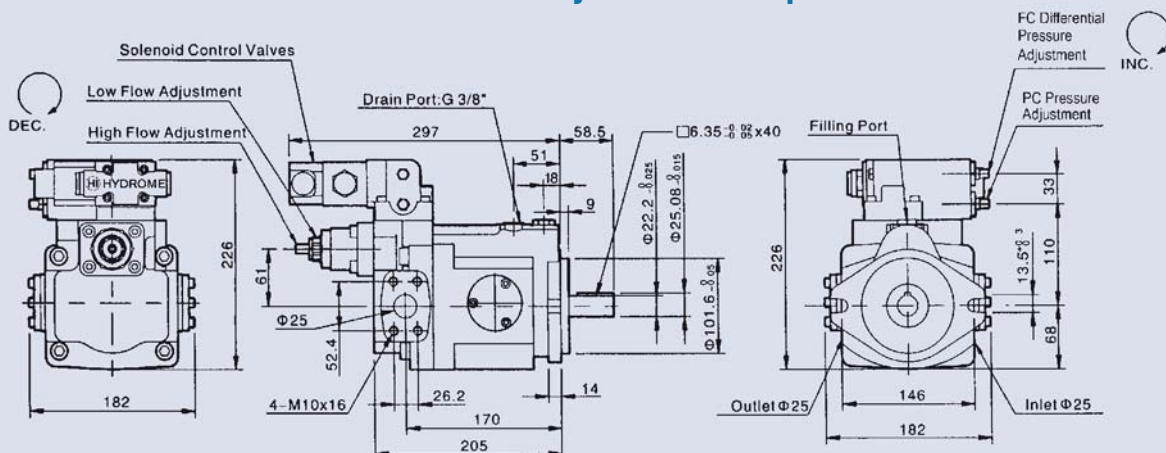

V SERIES AXIAL PISTON PUMP

Dimensions

V23FG, V25FG 2 Flow-2 Pressure Control by Solenoid Operated & Remote Valve

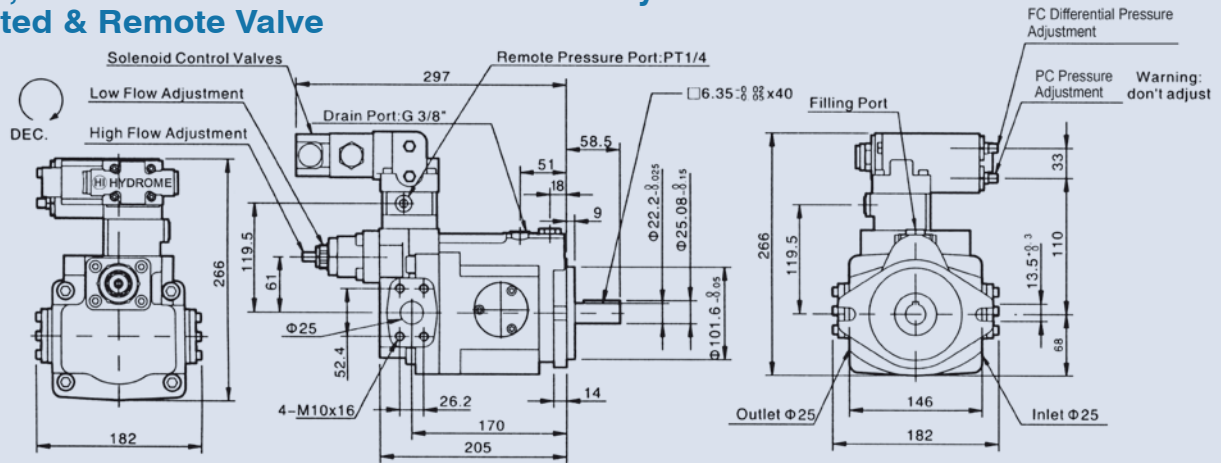

V23G, V25G Remoted Pressure Compensator Control

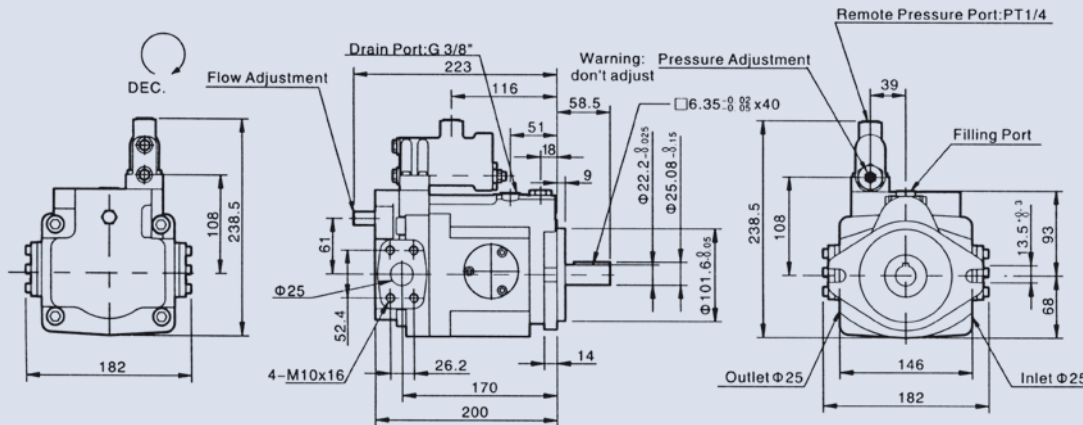

V23GJ, V25GJ Proportional Pressure with interface

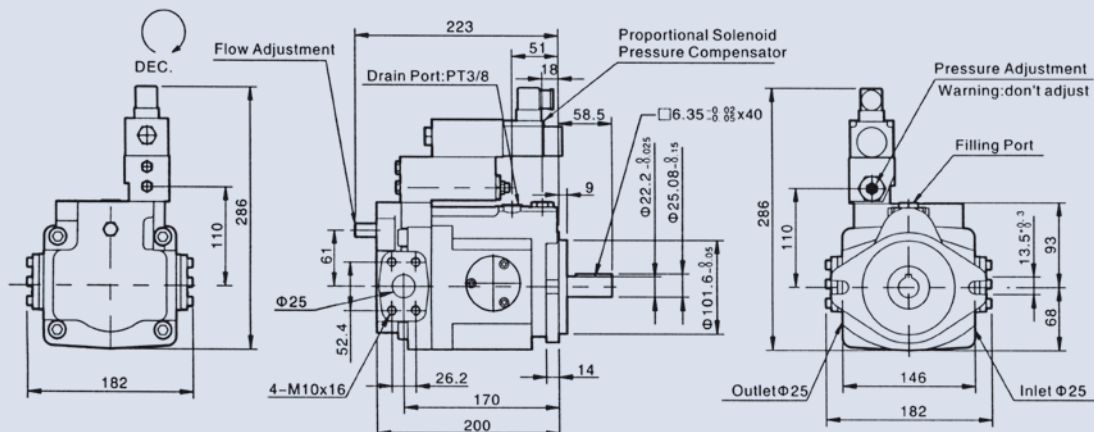

V SERIES AXIAL PISTON PUMP

Dimensions

V23GM, V25GM Remoted Interface (Not include valve)

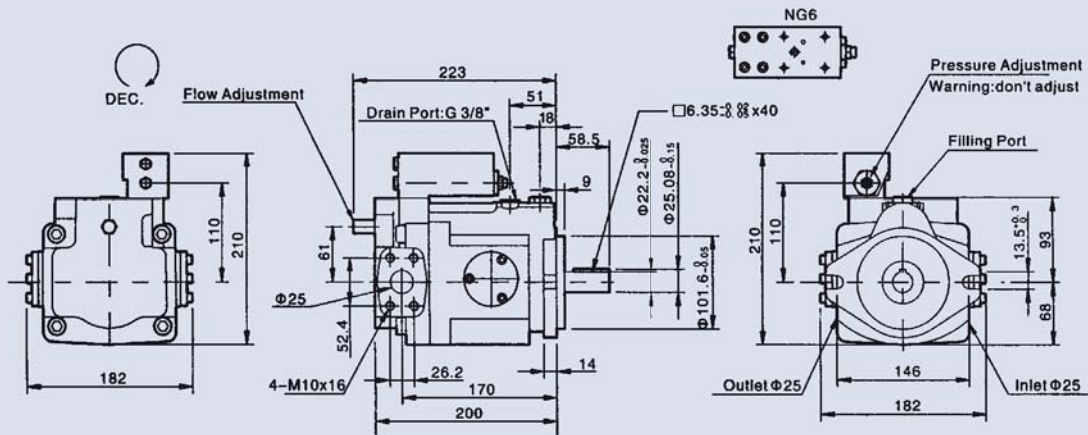

V23HL, V25HL Load-Sensing Compensator

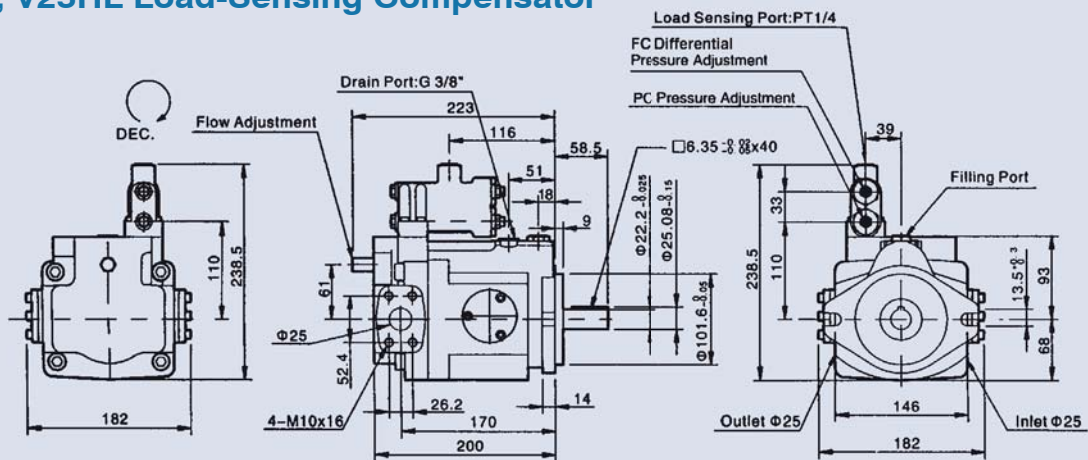

V23HK, V25HK Proportional Electro-hydraulic Load Sensing Type

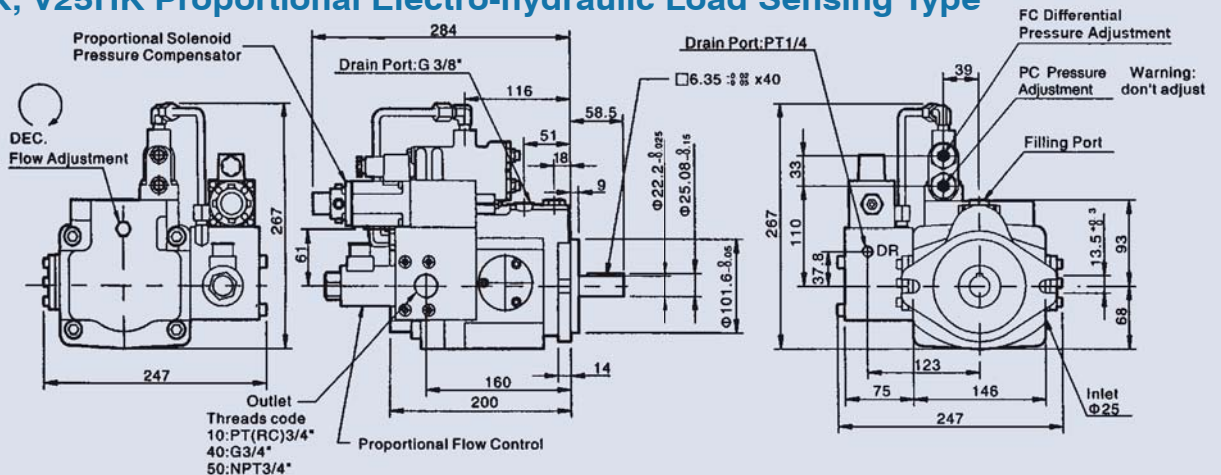

V SERIES AXIAL PISTON PUMP

Dimensions

V23, V25 Axial Port

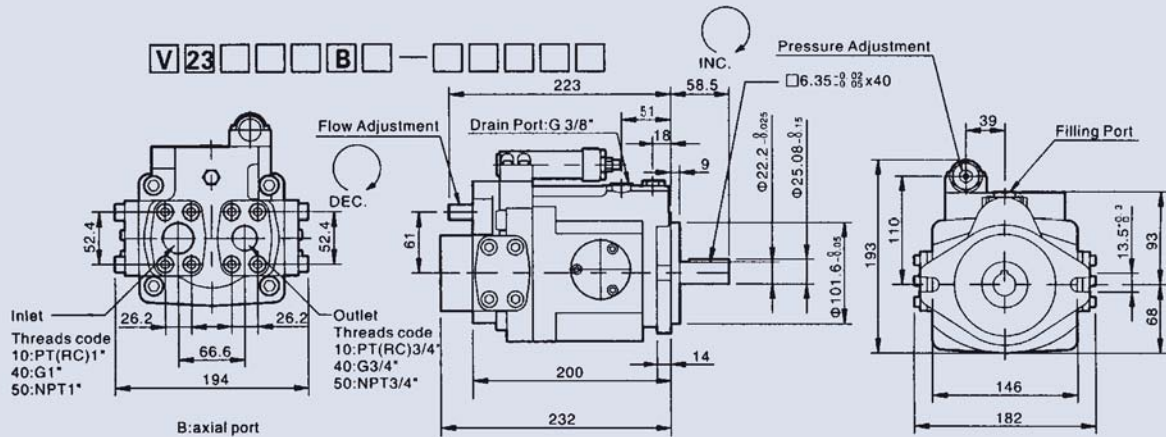

V23, V25 4 Connections for Axial Port

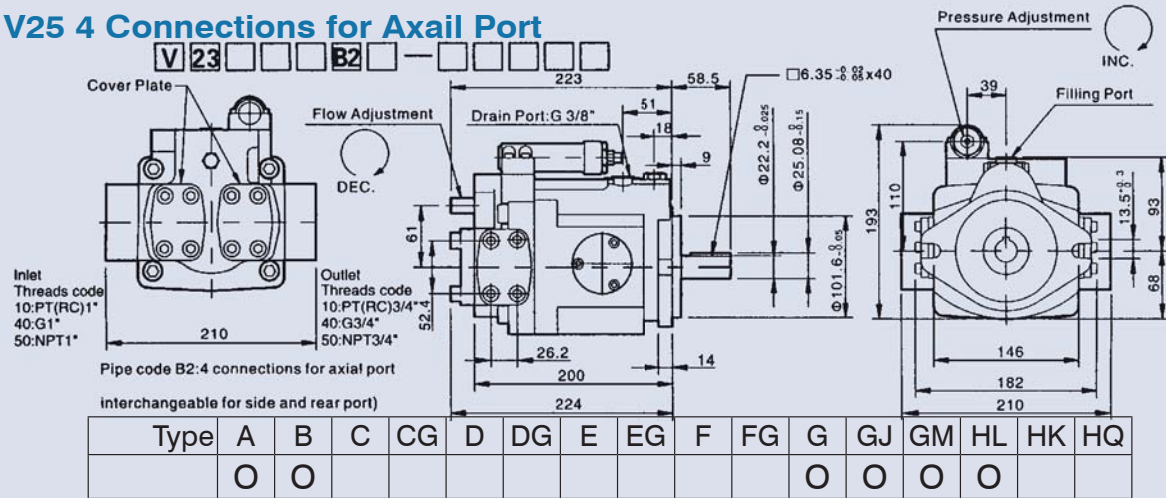

V23, V25 Splined Shaft Type

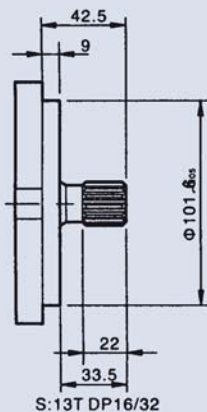

V23, V25 Hydraulic Flange

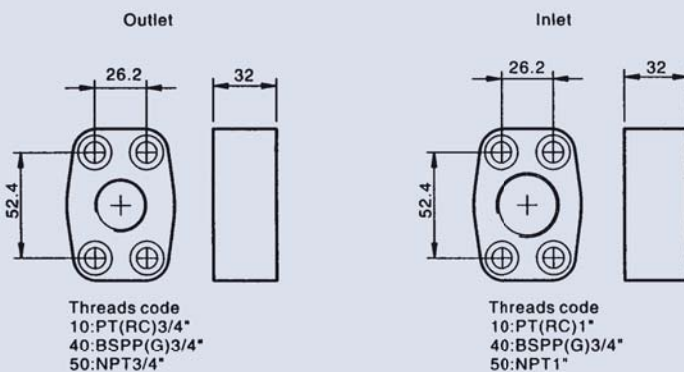

V SERIES AXIAL PISTON PUMP

Dimensions

V38A, V42A Pressure Compensator

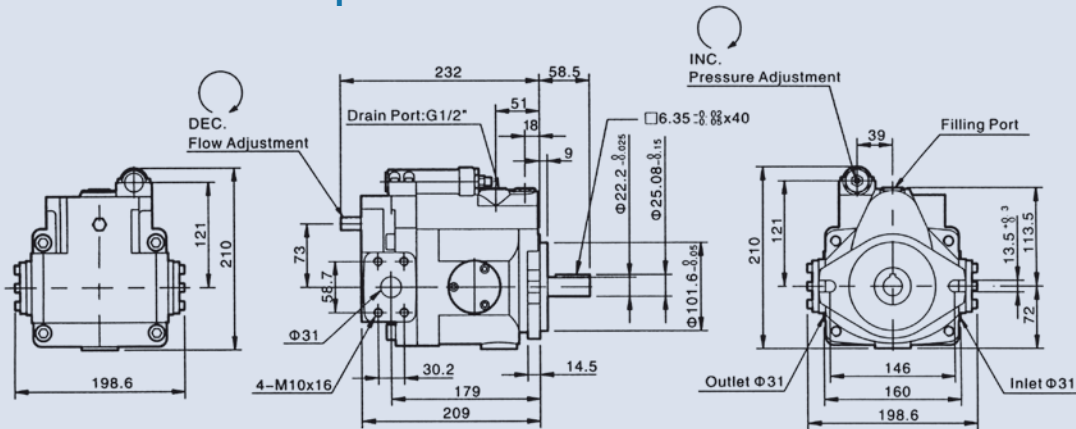

V38B, V42B Multi-stage Flow & Single-stage Pressure Compensator Control (With cylinder)

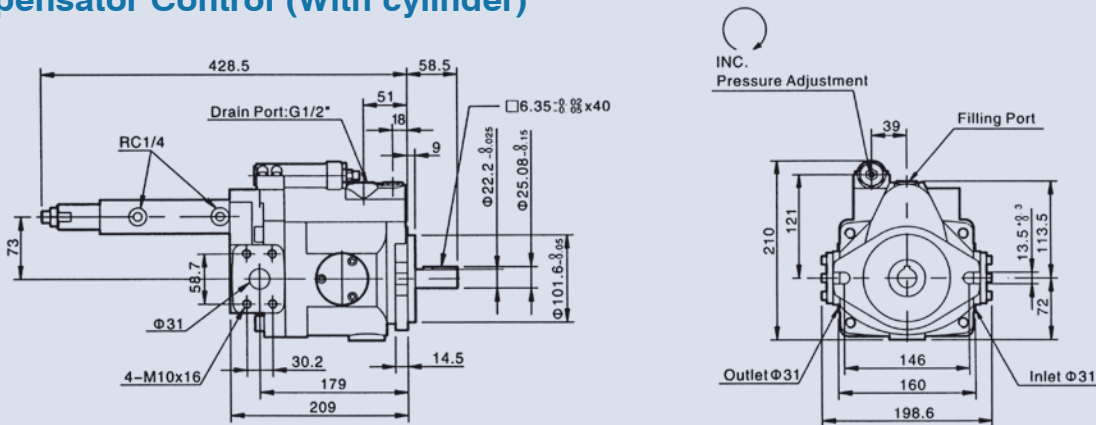

V38C, V42C 2-stage Pressure & Flow Control Type

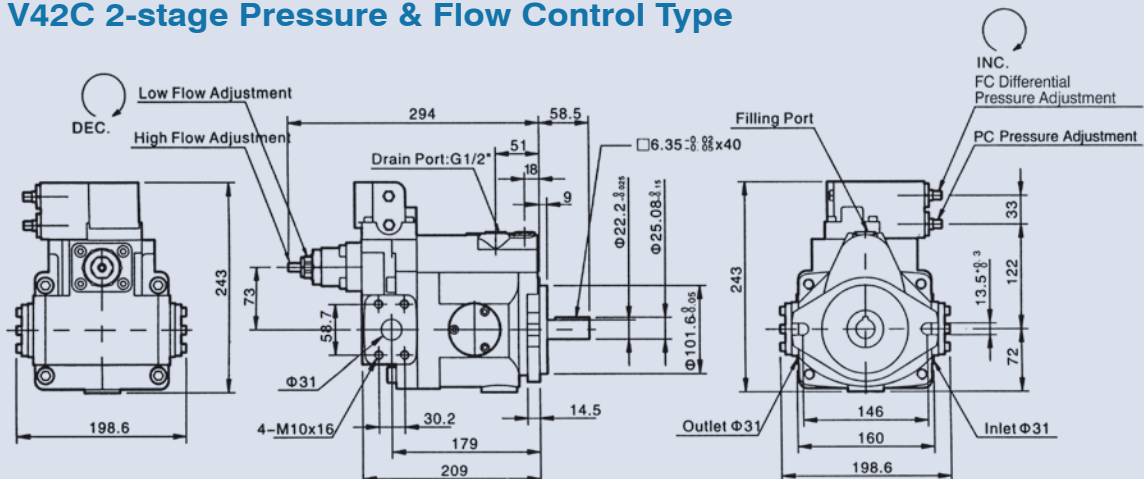

V SERIES AXIAL PISTON PUMP

Dimensions

V38CG, V42CG 2-stage Pressure & Flow Control Type with Remote

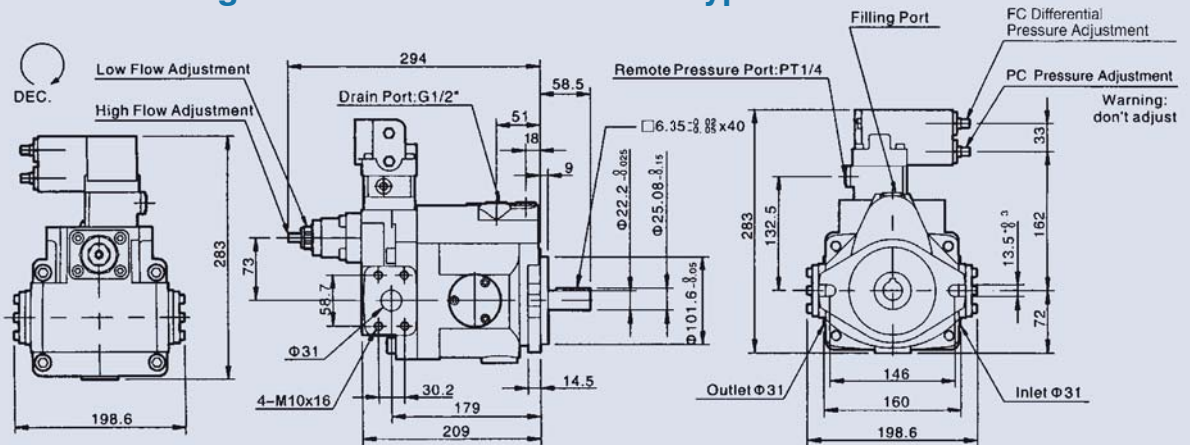

V38D, V42D Solenoid Controlled Pressure Compensating Type with Unloading Device

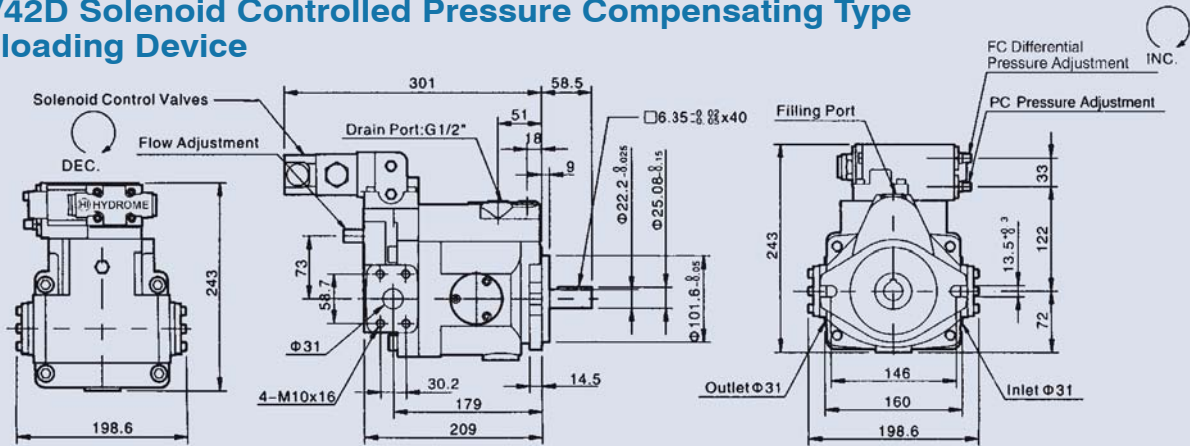

V38DG, V42DG Solenoid Controlled Pressure Compensating Type with Unloading Device & Remote

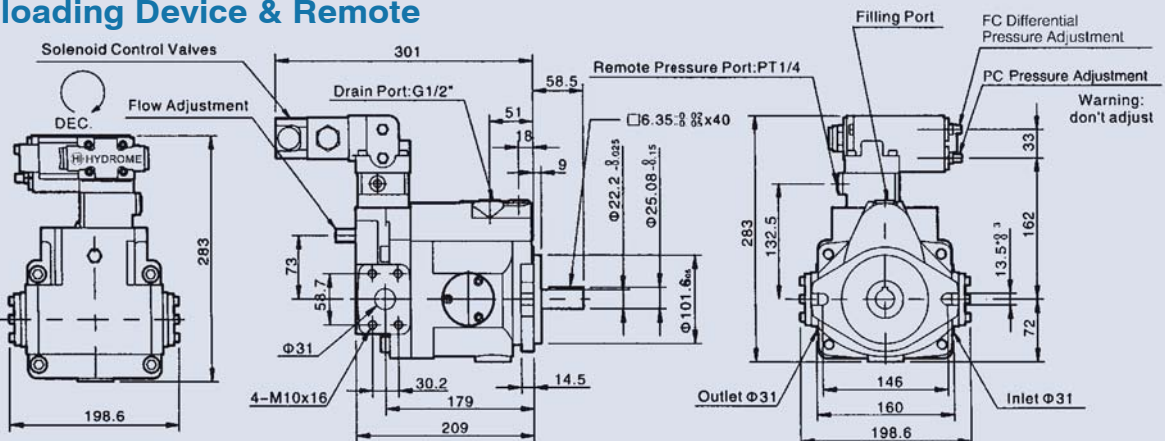

V SERIES AXIAL PISTON PUMP

Dimensions

V38E, V42E Dual Pressure Control

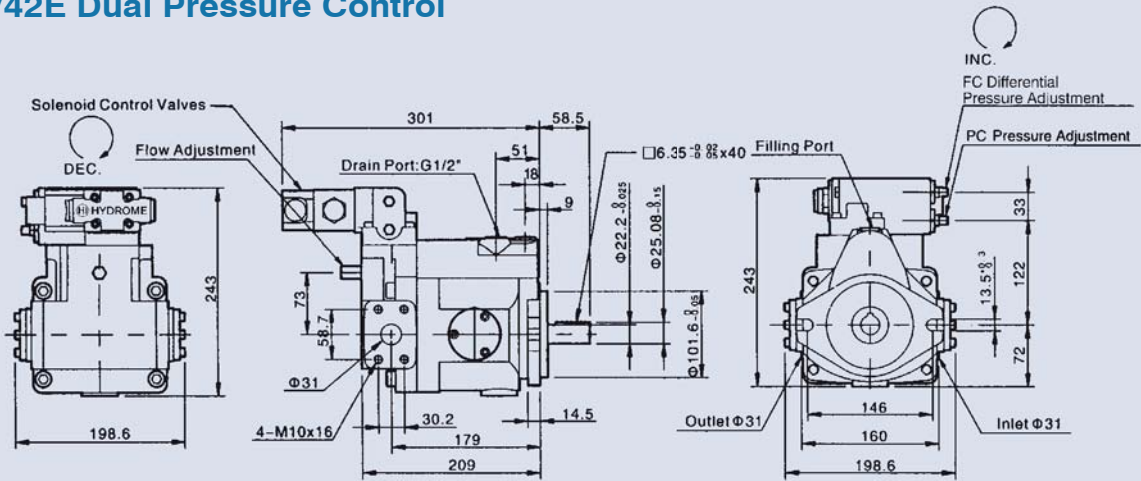

V38EG, V42EG Dual & Remote Pressure Control

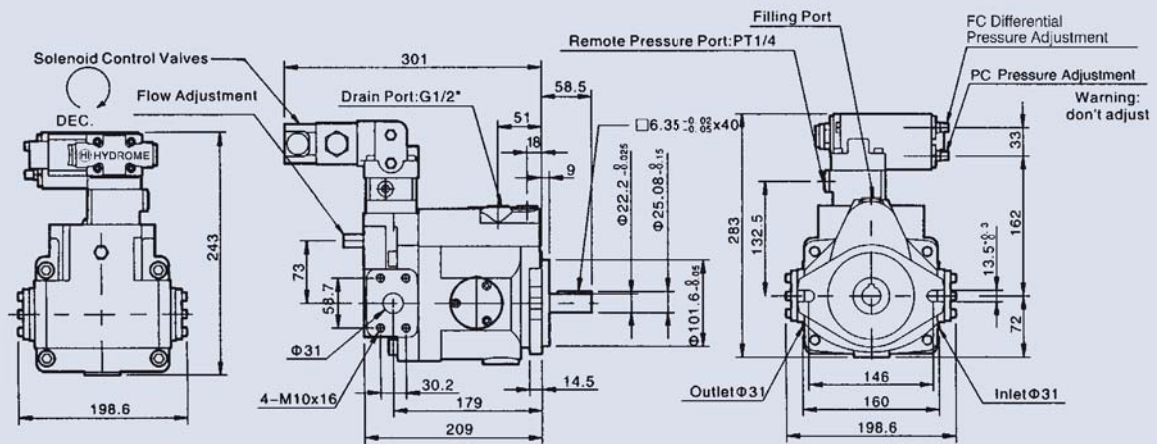

V38F, V42F Flow-2 Pressure Control by Solenoid Operated Valve

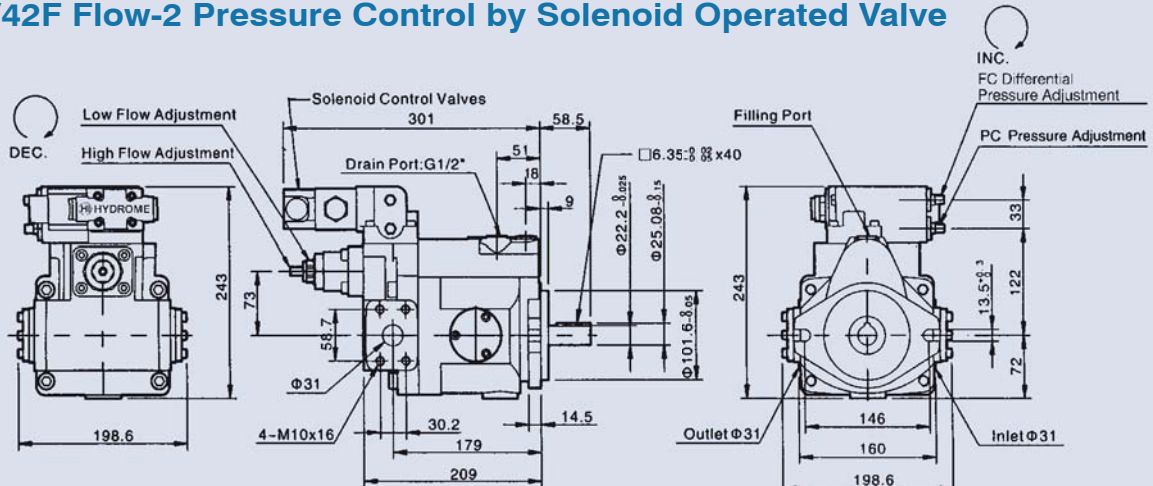

V SERIES AXIAL PISTON PUMP

Dimensions

V38FG, V42FG 2 Flow-2 Pressure Control by Solenoid Operated & Remote Valve

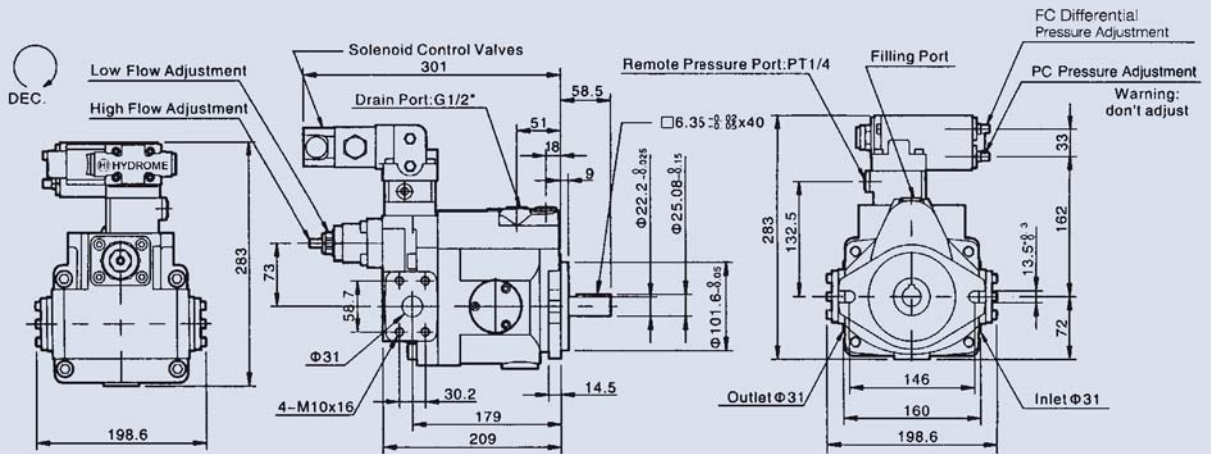

V38G, V42G Remoted Pressure Compensator Control

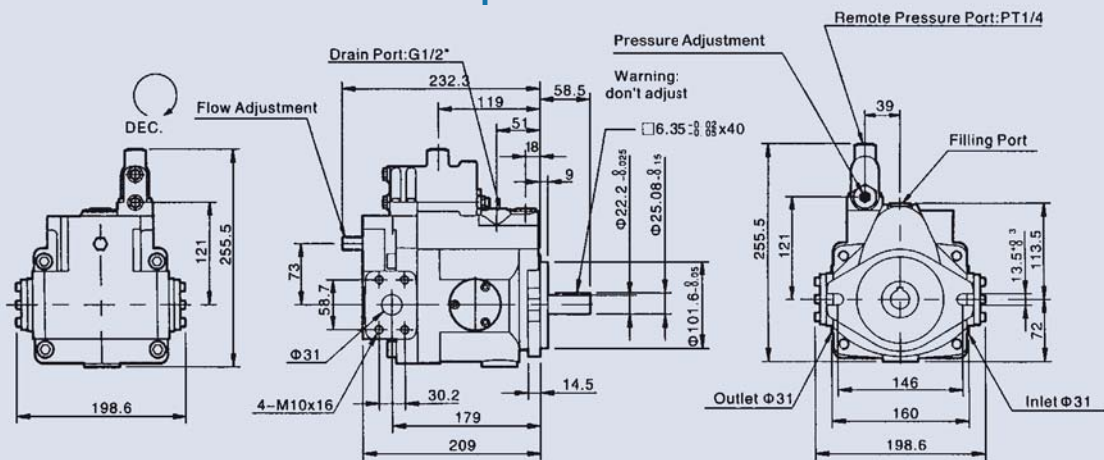

V38GJ, V42GJ Proportional Pressure with Interface

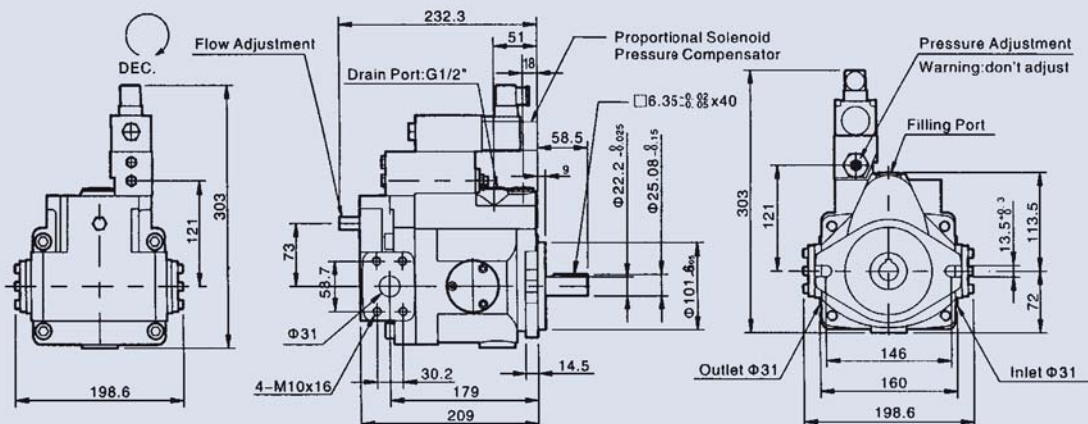

V SERIES AXIAL PISTON PUMP

Dimensions

V38GM, V42GM Remote Interface (Not include valve)

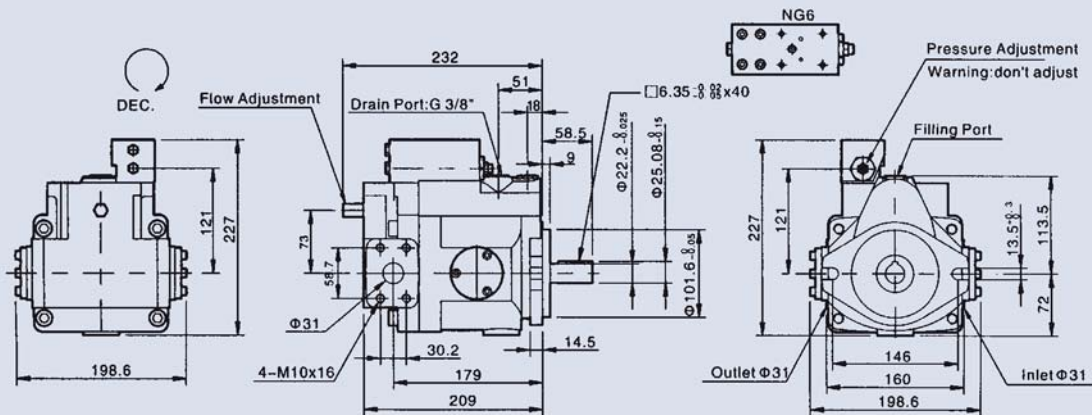

V38HL, V42HL Load-sensing Compensator

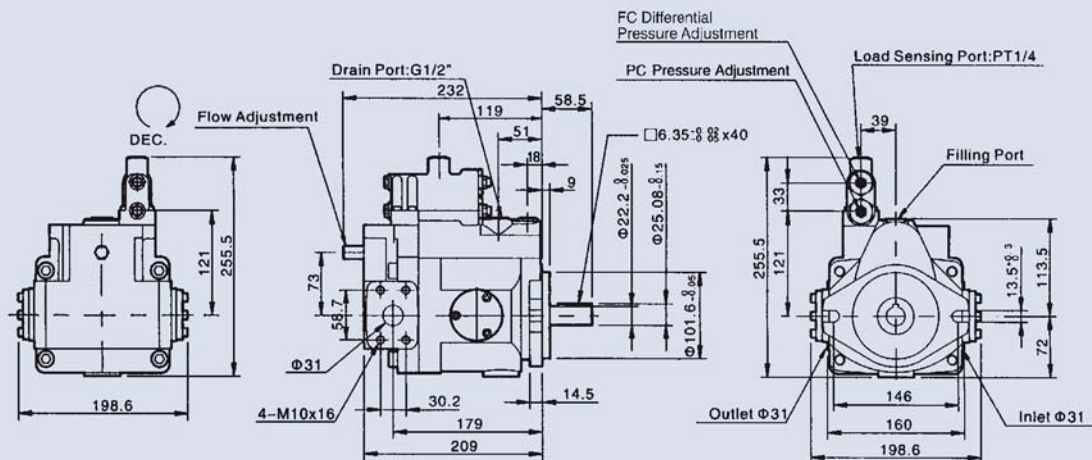

V38HK, V42HK Proportional Electro-hydraulic Load Sensing Type

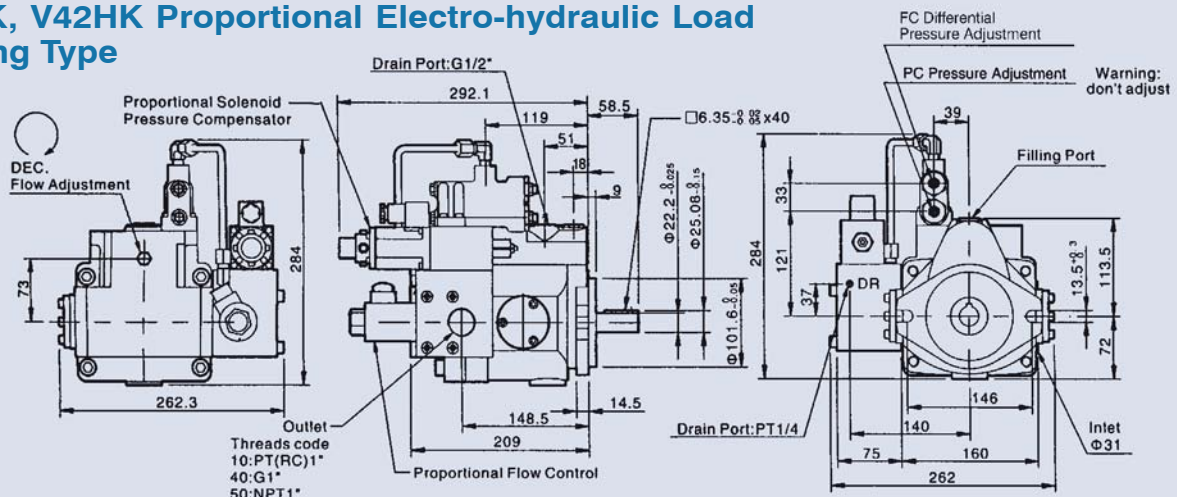

V SERIES AXIAL PISTON PUMP

Dimensions

V38HQ, V42HQ Load-sensing Proportional Flow Control

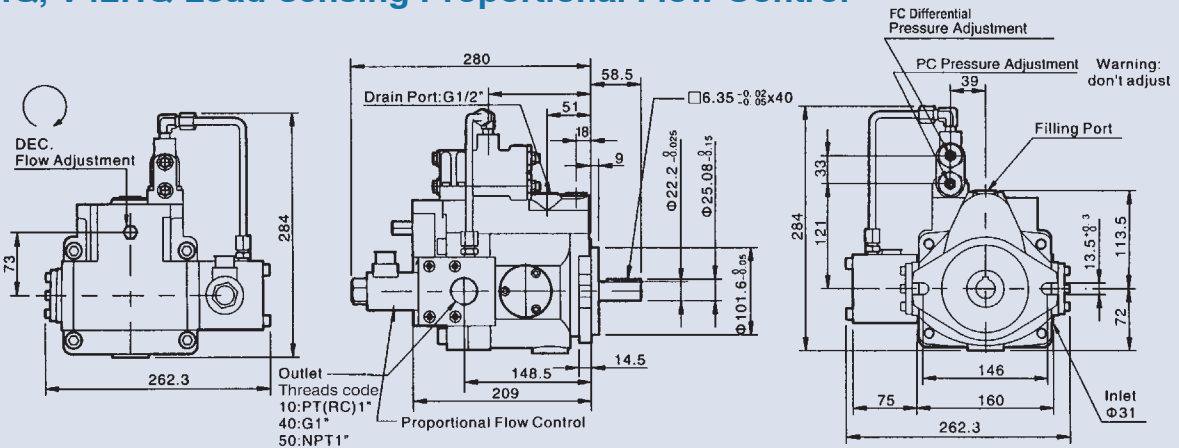

V38, V42 Prepared for Thru Drive (SAE A $\phi 82.55$)

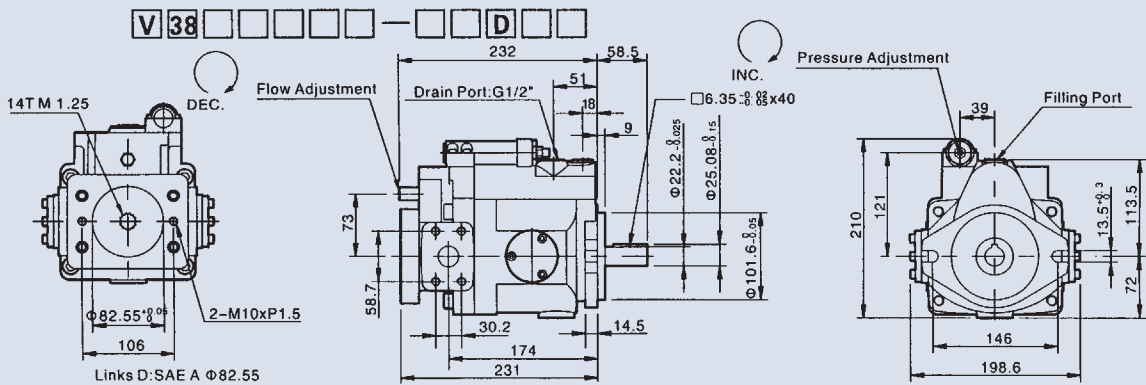

V38, V42 Prepared for Thru Drive (SAE B $\phi 101.6$)

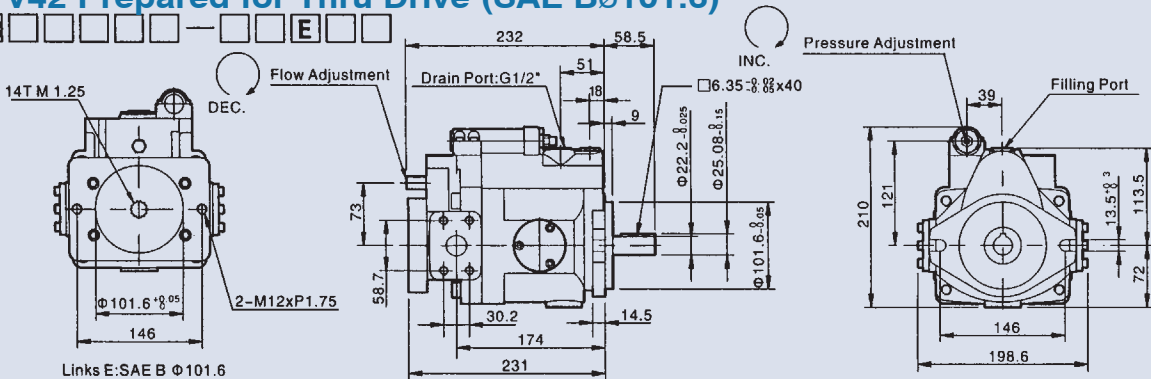

Type	A	B	C	CG	D	DG	E	EG	F	FG	G	GJ	GM	HL	HK	HQ
Thru Drive Option	O				O	O	O	O			O	O	O	O	O	O

V SERIES AXIAL PISTON PUMP

Dimensions

V38, V42 Axial Port

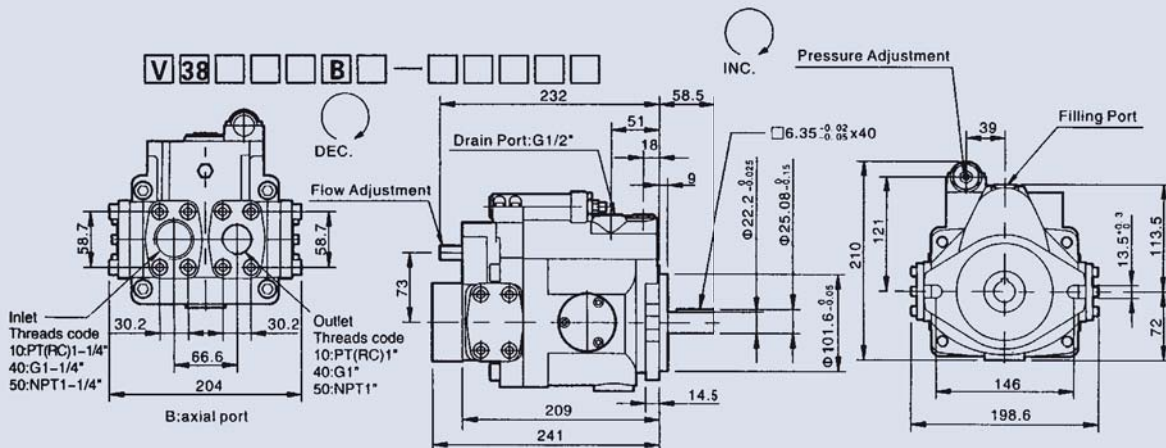

V38, V42 4 Connections for Axial Port

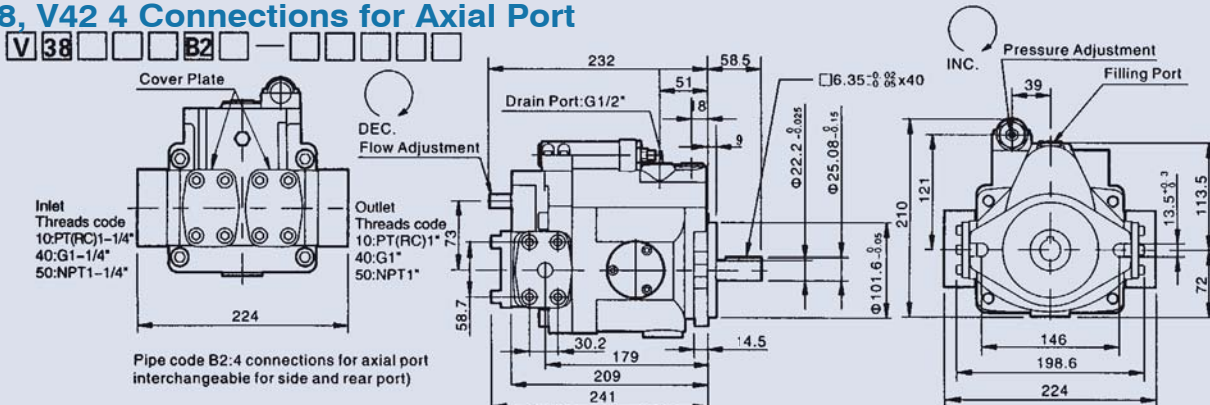

Type	A	B	C	CG	D	DG	E	EG	F	FG	G	GJ	GM	HL	HK	HQ
	○	○	○	○					○	○	○	○	○	○		

Axial Port Option

V38, V42 Splined Shaft Type

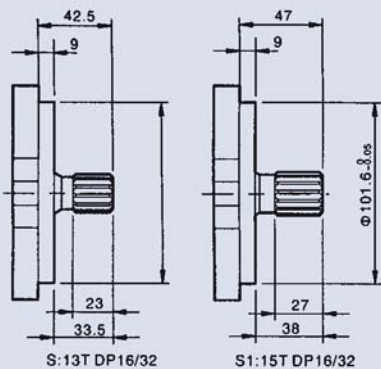

V38, V42 Hydraulic Flange

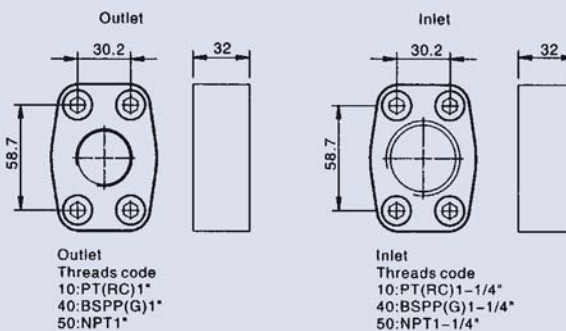

V SERIES AXIAL PISTON PUMP

Dimensions

V50A, V70A Pressure Compensator

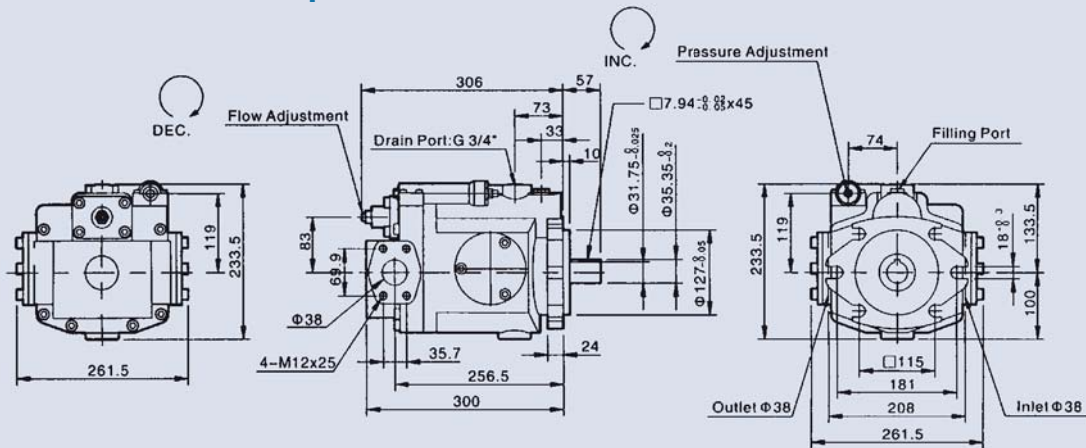

V50B, V70B Multi-stage Flow & Single-stage Pressure Compensator Control (With cylinder)

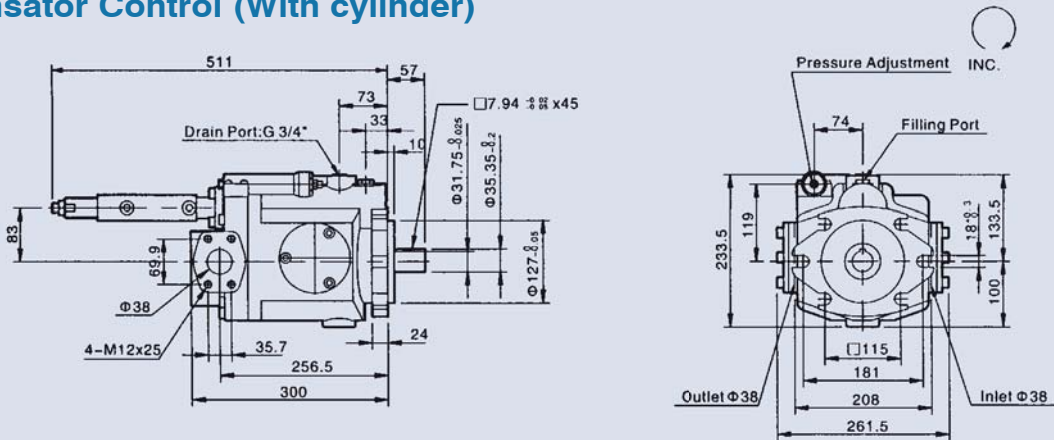

V50C, V70C 2-stage Pressure & Flow Control Type

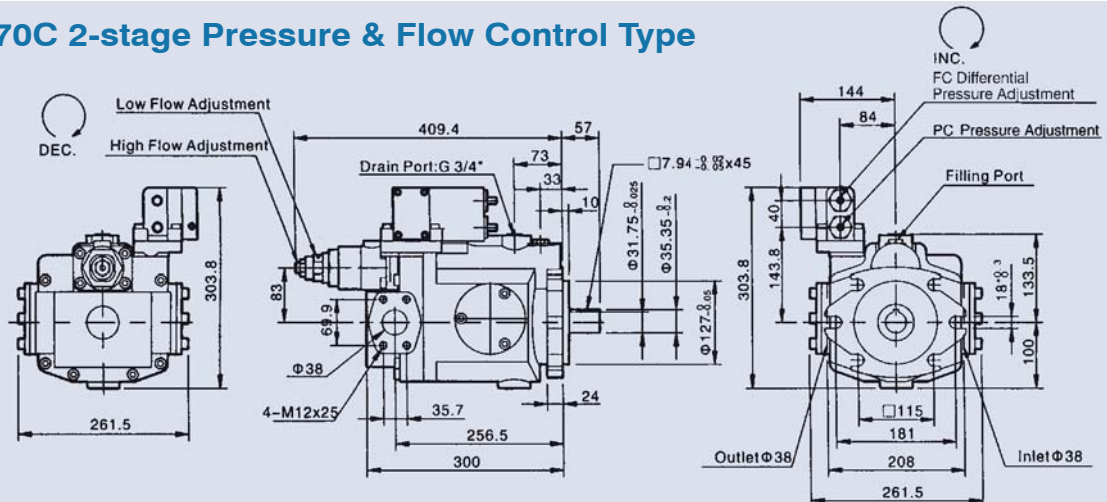

V SERIES AXIAL PISTON PUMP

Dimensions

V50D, V70D Solenoid Controlled Pressure Compensating Type with Unloading Device

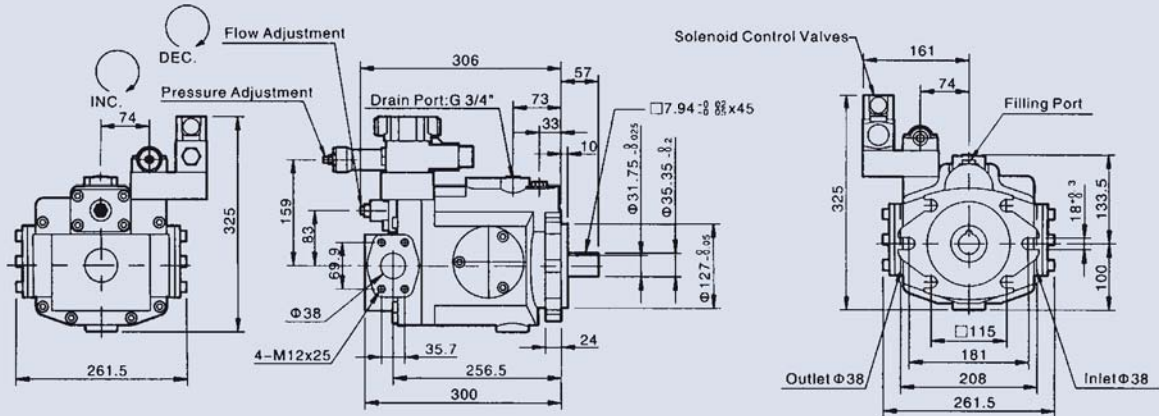

V50F, V70F 2 Flow-2 Pressure Control by Solenoid Operated Valve

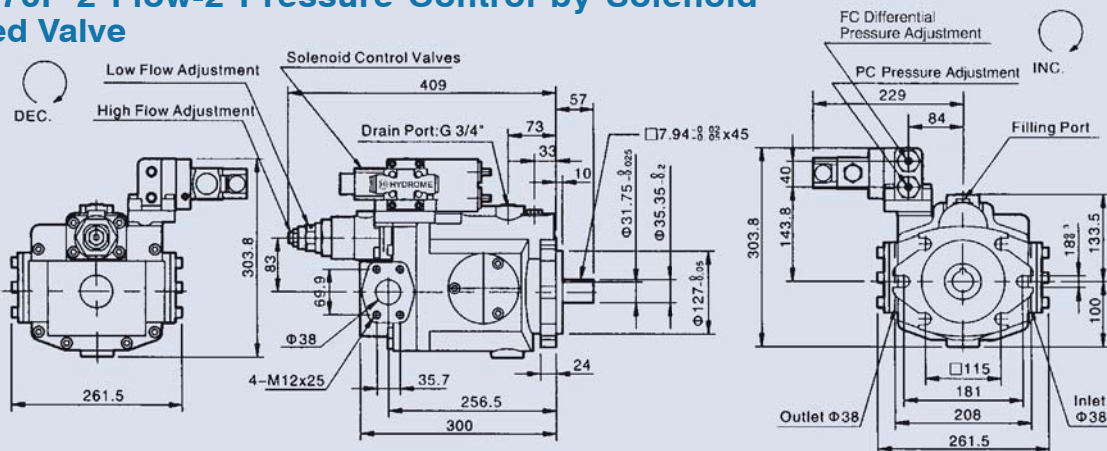

V50G, V70G Remoted Pressure Compensator Control

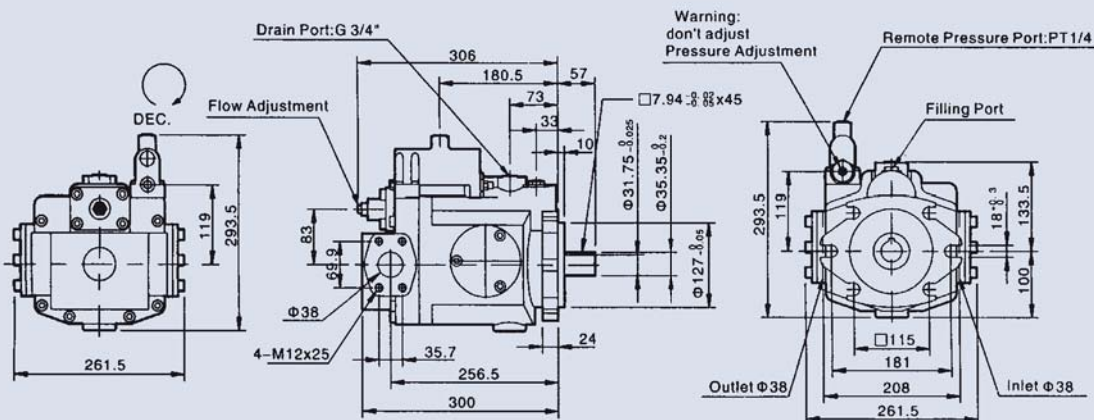

V SERIES AXIAL PISTON PUMP

Dimensions

V50GJ, V70GJ Proportional Pressure with interface

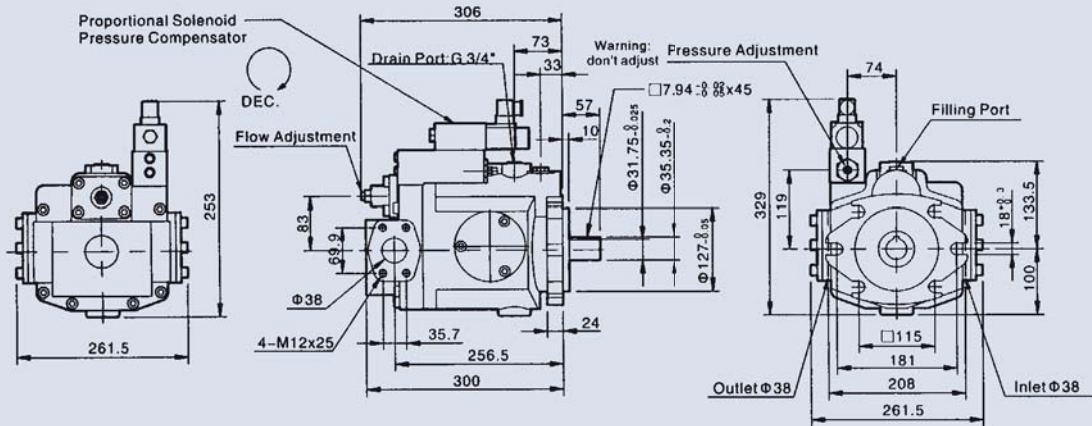

V50GM, V70GM Remote Interface (Not include valve)

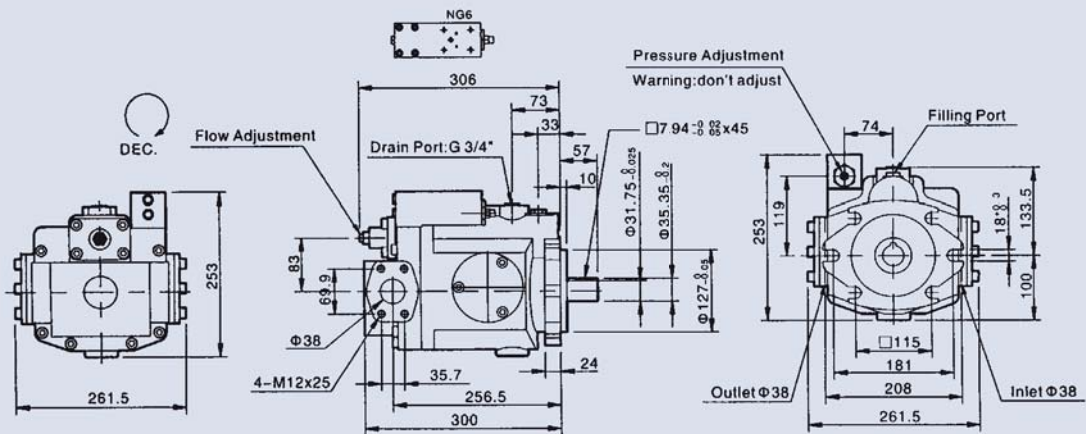

V50HL, V70HL Load-sensing Compensator

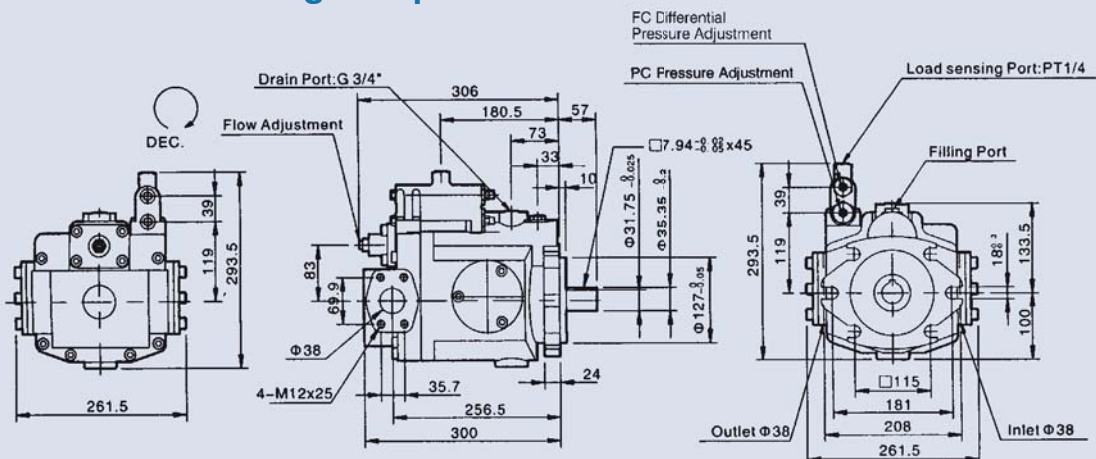

V SERIES AXIAL PISTON PUMP

Dimensions

V50HK, V70HK Proportional Electro-hydraulic Load Sensing Type

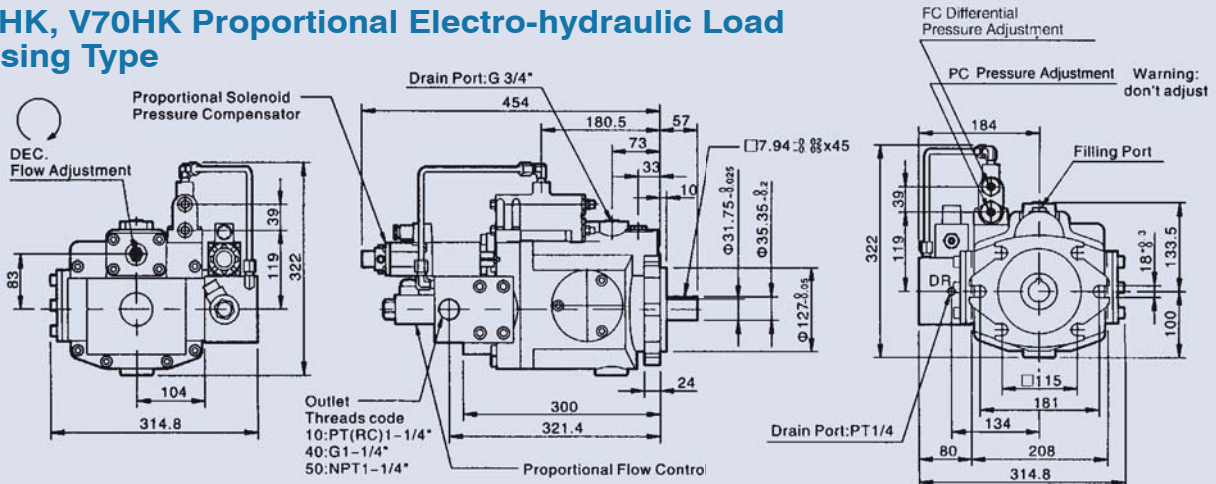

V50HQ, V70HQ Load-Sensing Proportional Flow Control

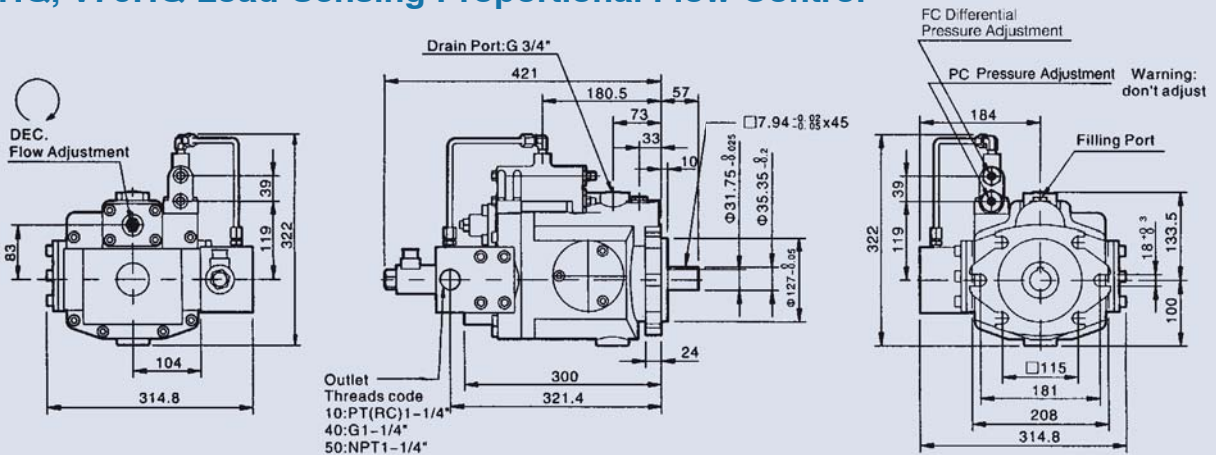

V50, V70 Splined Shaft Type

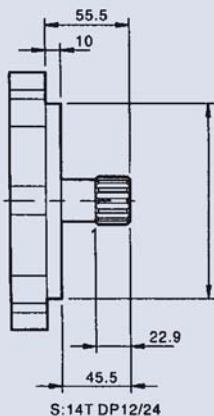

V50, V70 Hydraulic Flange

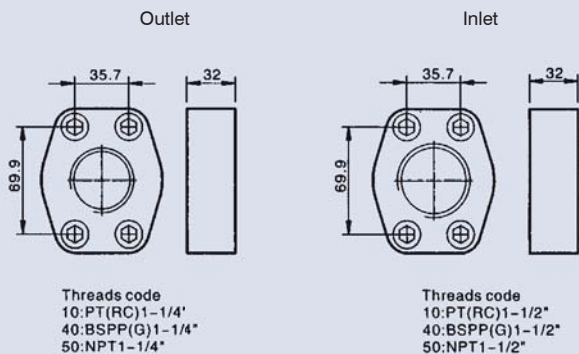

V SERIES AXIAL PISTON PUMP

Dimensions

V50, V70 Prepared for Thru Drive (SAE Aø82.55, SAE Bø101.6)

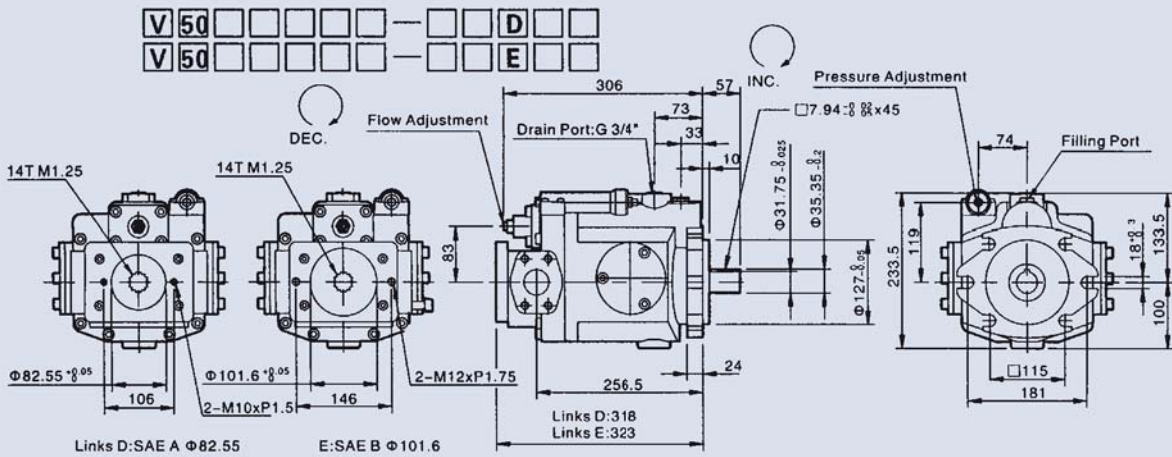

Type	A	B	C	CG	D	DG	E	EG	F	FG	G	GJ	GM	HL	HK	HQ
	O				O	O	O	O			O	O	O	O	O	O

Thru Drive Option

V50, V70 Axial Port

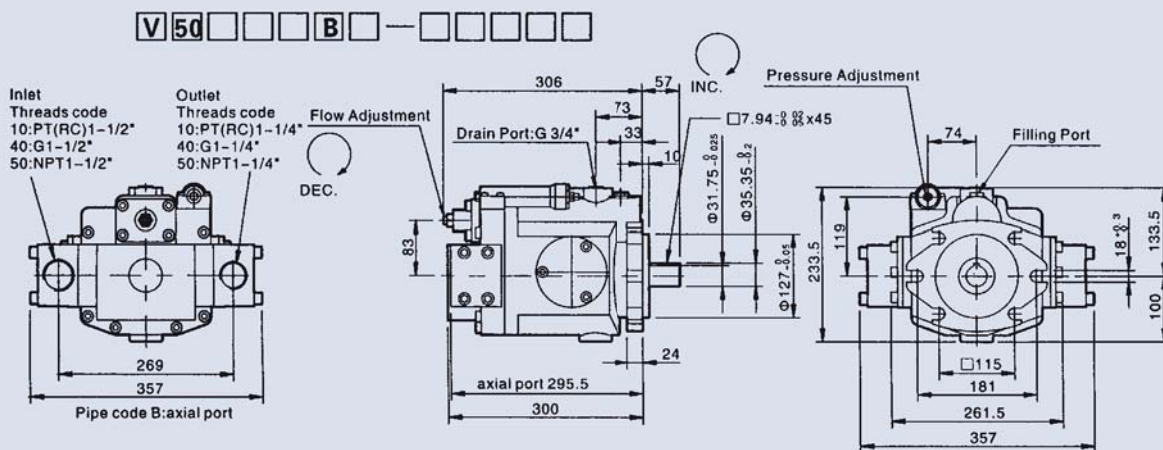

Type	A	B	C	D	F	G	GJ	GM	HL	HK	HQ
	O	O	O	O	O	O	O	O	O		

Axial Port Option

V SERIES AXIAL PISTON PUMP

Decomposition Chart

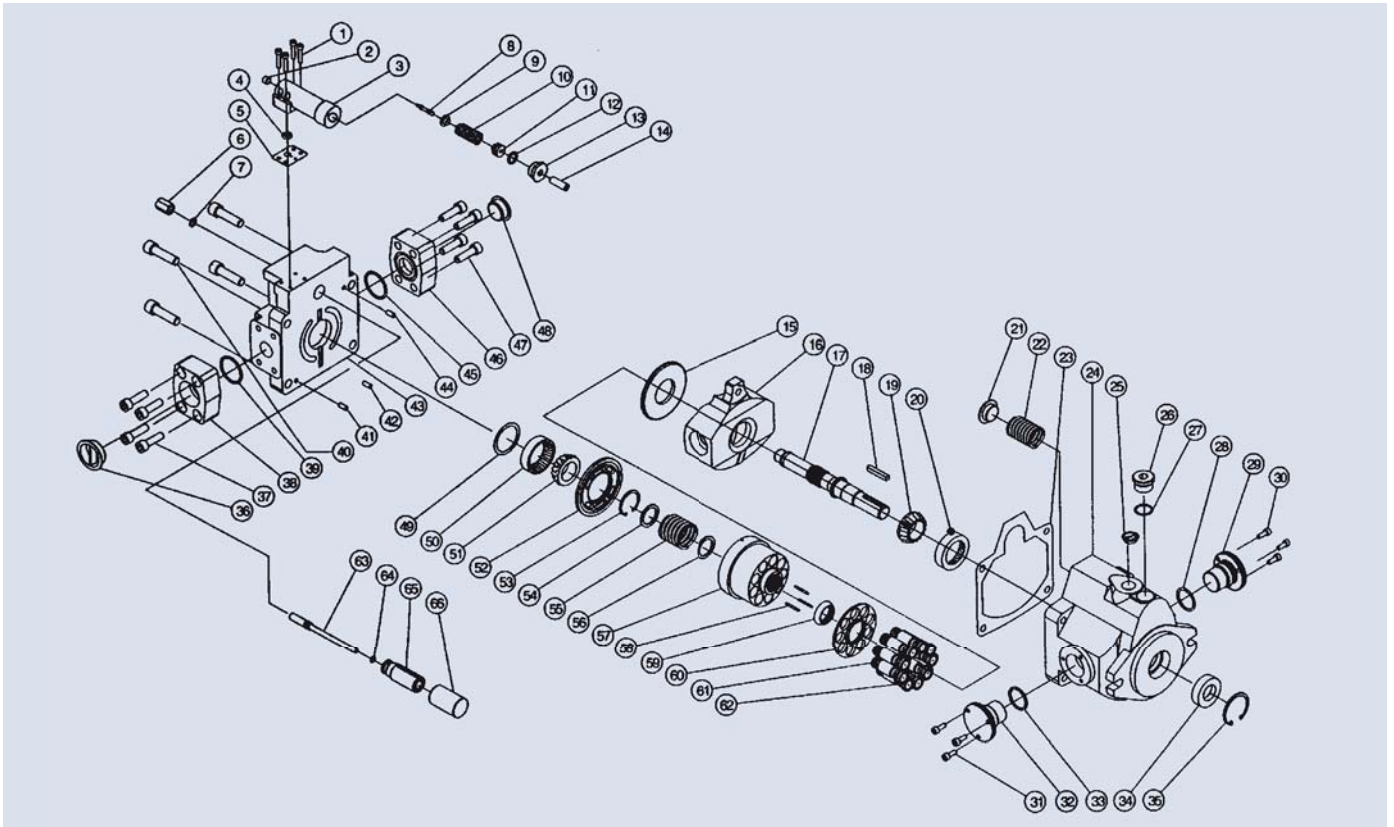

List of parts

No.	Description	No.	Description	No.	Description	No.	Description
1	Bolt	18	Shaft Key	35	M snap ring	52	Valve plate
2	Port plug	19	Bearing of shaft	36	Plug	53	Snap ring
3	Pressure compensator	20	Bearing of shaft	37	Bolt	54	Washer cylinder block
4	O-ring	21	Servo spring washer	38	Flange	55	Retainer spring
5	Gasket	22	Servo spring	39	O-ring	56	Washer cylinder block
6	Lock nut	23	End cover seal	40	Bolt	57	Cylinder block
7	O-ring	24	Pump body	41	Roller	58	Roller
8	Control compensator shaft	25	Drain plug	42	Roller	59	Cylinder block holder
9	Spring washer	26	Filling screw	43	End cover	60	Slipper retainer
10	Control spring	27	O-ring	44	Roller	61	Pistons
11	O-ring washer	28	O-ring	45	O-ring	62	Piston head
12	O-ring	29	Swash shaft	46	Flange	63	Flow screw
13	Lock nut	30	Bolt	47	Bolt	64	O-ring
14	Screw	31	Bolt	48	Plug	65	Sleeve piston
15	Slipper plate	32	Swash shaft	49	Washer cylinder block	66	Servo piston sleeve
16	Swash	33	O-ring	50	Bearing of pump cover		
17	Shaft	34	Shaft seal	51	Bearing of pump cover		

VR SERIES AXIAL PISTON PUMP

Dimensions

VR15A ❖❖B- ❖Axial Port

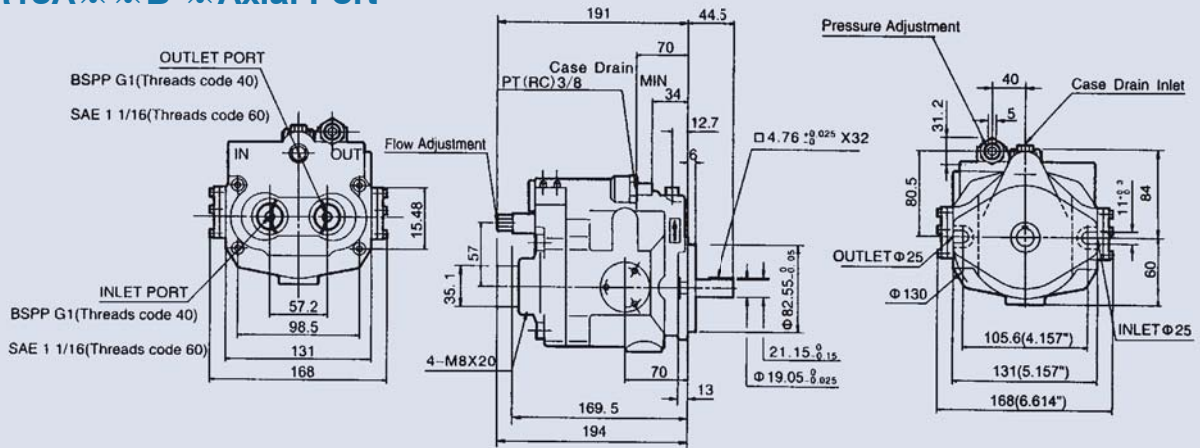

VR23A ❖❖B- ❖Axial Port (Pipe type)

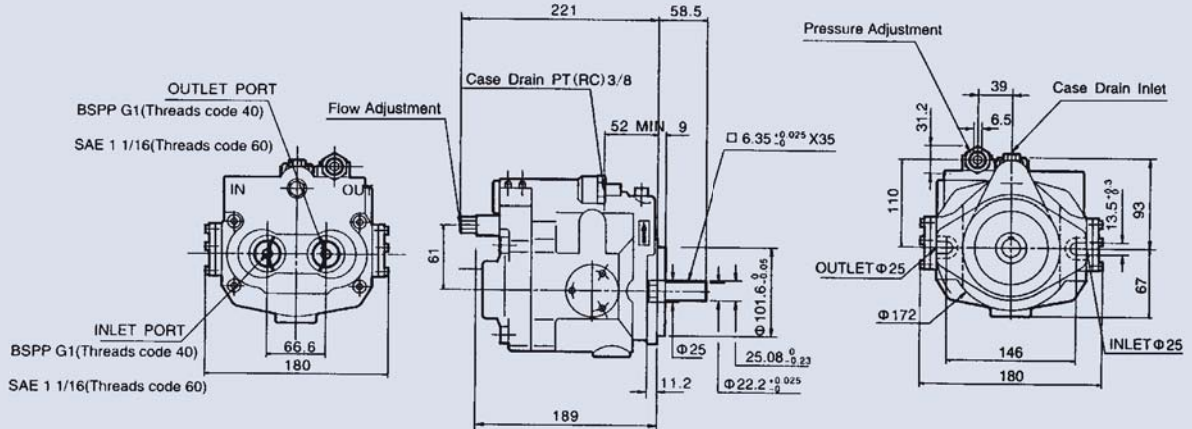

VR38A ❖❖B- ❖Axial Port (Pipe type)

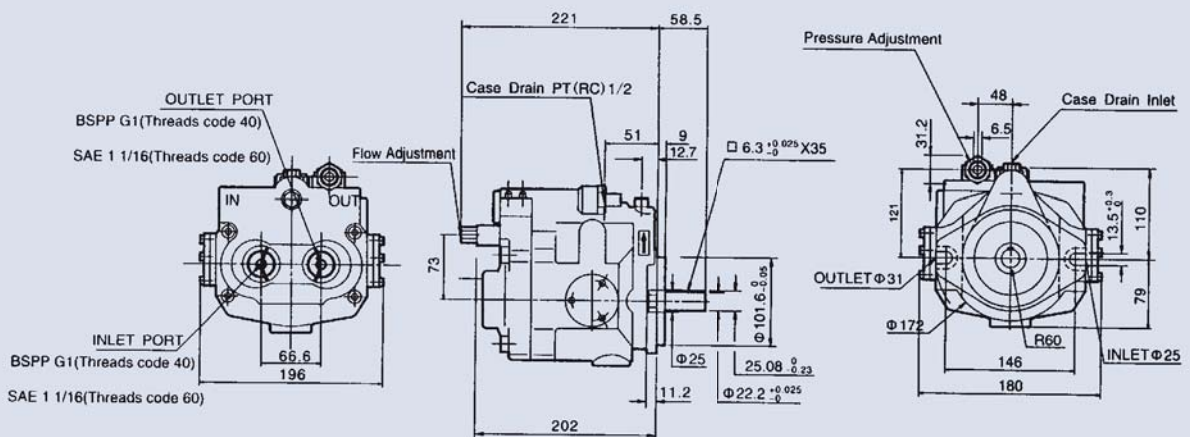

V SERIES TANDEM AXIAL PISTON PUMP

Tandem pump (Multi-option for tandem pump)

Pump 1	V15(V18)	V23(V25)	V23(V25)	V38(V42)	V38(V42)	V38(V42)	V50(V70)	V50(V70)	V50(V70)
Pump 2	V15(V18)	V15(V18)	V23(V25)	V15(V18)	V23(V25)	V38(V42)	V15(V18)	V23(V25)	V38(V42)
A	G 3/8"	G 3/8"	G 3/8"	G 3/8"	G 3/8"	G 1/2"	G 3/8"	G 3/8"	G 1/2"
B	G 3/8"	G 3/8"	G 3/8"	G 1/2"	G 1/2"	G 1/2"	G 3/4"	G 3/4"	G 3/4"
C	57.45	57.45	61	57.45	61	73	57.45	61	73
D	35.1	35.1	52.4	35.1	52.4	58.7	35.1	52.4	58.7
E	35.1	35.1	26.2	35.1	26.2	30.2	35.1	26.2	30.2
F	35.1	52.4	52.4	58.7	58.7	58.7	69.9	69.9	69.9
G	35.1	26.2	26.2	30.2	30.2	30.2	35.7	35.7	35.7
H	M8×20	M8×20	M10×16	M8×20	M10×16	M10×16	M8×20	M10×16	M10×16
I	M8×20	M10×16	M10×16	M10×16	M10×16	M10×16	M12×25	M12×25	M12×25
J	147	147	170	147	170	179	147	170	179
K	147	170	170	179	179	179	256.5	256.5	256.5
L	332	369	402	378	401	410	464	493	502
M	382	419	455	428	454	465	515	546	555
N	48	48	51	48	51	51	48	51	51
O	48	51	51	51	51	51	73	73	73
P	6	9	9	9	9	9	10	10	10
Q	4.76×32	6.35×40	6.35×40	6.35×40	6.35×40	6.35×40	7.94×45	7.94×45	7.94×45
R	13	14	14	14.5	14.5	14.5	24	24	24
S	ø19.05	ø22.22	ø22.22	ø22.22	ø22.22	ø22.22	ø31.75	ø31.75	ø31.75
T	21.15	25.08	25.08	25.08	25.08	25.08	35.35	35.35	35.35
U	ø82.55	ø101.6	ø101.6	ø101.6	ø101.6	ø101.6	ø127	ø127	ø127
V	ø25	ø25	ø25	ø31	ø31	ø31	ø38	ø38	ø38
W	ø25	ø25	ø25	ø31	ø31	ø31	ø38	ø38	ø38
X	106	146	146	146	146	146	181	181	181
Y	131	146	146	160	160	160	208	208	208
Z	165	182	182	198.6	198.6	198.6	261.5	261.5	261.5
A1	44	39	39	39	39	39	74	74	74
A2	31.2	31.2	31.2	31.2	31.2	31.2	40	40	40
A3	5	5	5	5	5	5	8	8	8
A4	84	110	110	121	121	121	119	119	119
A5	11	13.5	13.5	13.5	13.5	13.5	18	18	18
A6	44.5	58.5	58.5	58.5	58.5	58.5	57	57	57
A7	160	193	193	210	210	210	233.5	233.5	233.5
A8	91.5	93	93	113.5	113.5	113.5	133.5	133.5	133.5
A9	60	68	68	72	72	72	100	100	100

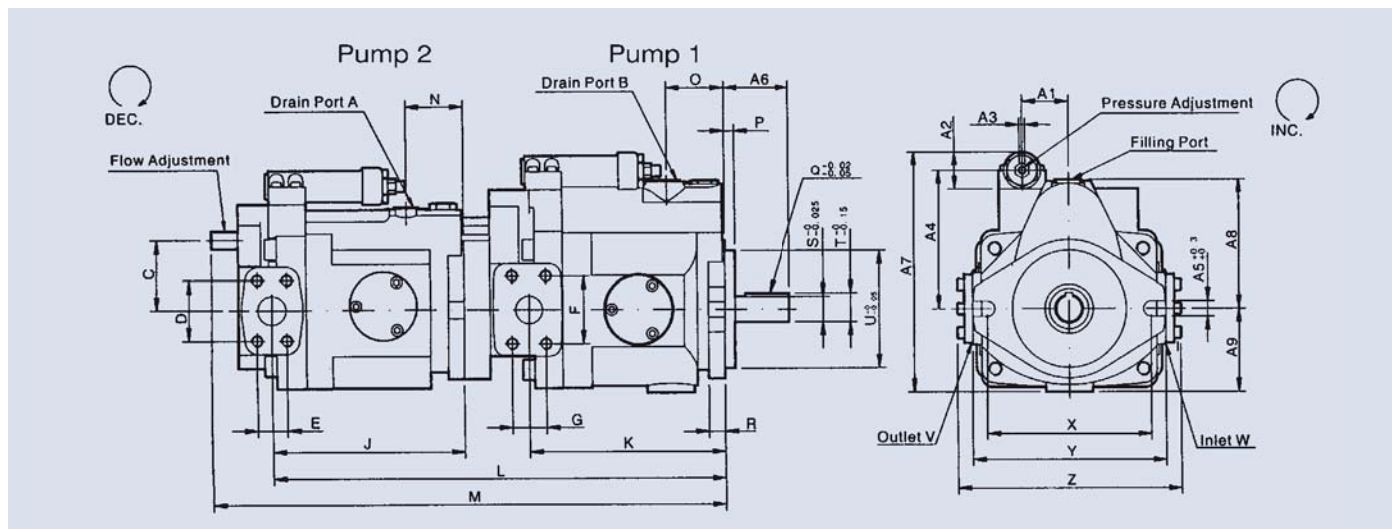

AR SERIES AXIAL PISTON PUMP

AR Control Type (see page. 15,16,17)



- 01: Pressure Compensator
- G: Remote Pressure Compensator
- GJ: Layer Porportional Pressure Compensator
- GR: Electrical Unloading
- GB: Dual Pressure Control
- GC: Dual Pressure+Electrical Unloading
- GM: Remote Pressure Compensator allows a pilot valve
- HL: Load-sensing Compensator

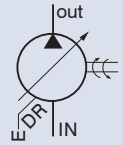

Ordering Codes

※Standard

Model	F	R	01	C	S	K	10	Y
	Mounting	Direction of Rotation	Control Type	Pres. Adj. Range bar (MPa)	Port Position	Shaft Extension	Threads Code	Design
AR16 (15.8cc/rev)	F: Flange Mtg.	Viewed from Shaft End * R: Clockwise (Standard) L: Counter Clockwise	01: Pressure Compensator Type HL: Load Sensing Compensator G: Remote Pressure Compensator	B:12~70 (1.2~7) C:12~210 (1.2~21)	None: Axial Port S: Side Port	*K: Keyed G: 16/32 DP-13T T: 16/32 DP-9T	*10: PT(RC) thread 40: BSPP(G) thread 50: NPT thread	X *Y
AR22 (22.2cc/rev)								

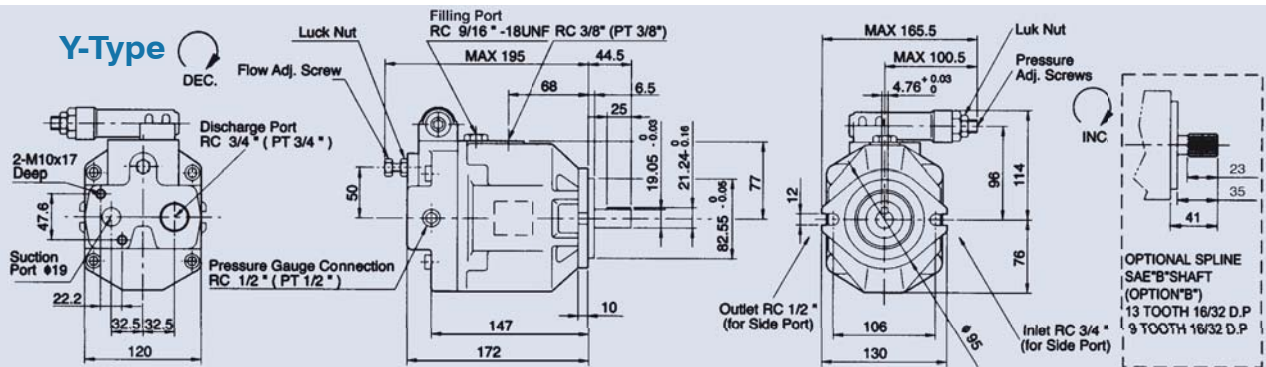

AR-16 Input Speed:1800 rpm/min

Fluid:Standard Hydraulic Oil ISO VG32 @50°C

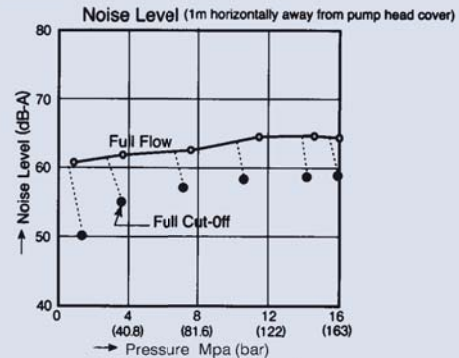
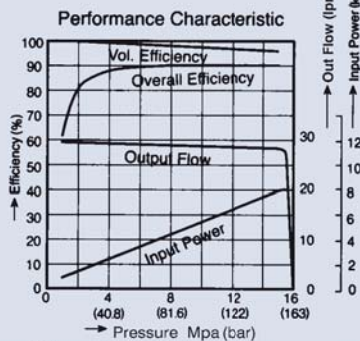

AR-22 Input Speed:1800 rpm/min

Fluid:Standard Hydraulic Oil ISO VG32 @50°C

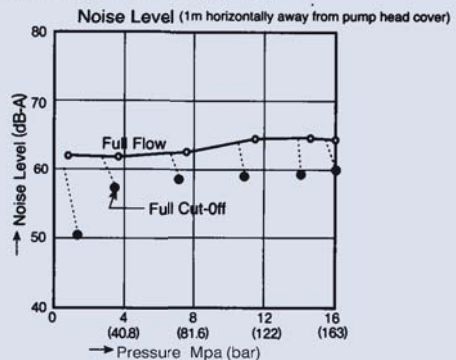
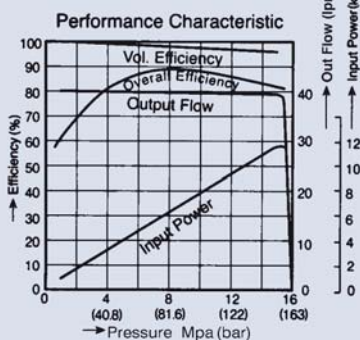

AR SERIES AXIAL PISTON PUMP

Decomposition Chart

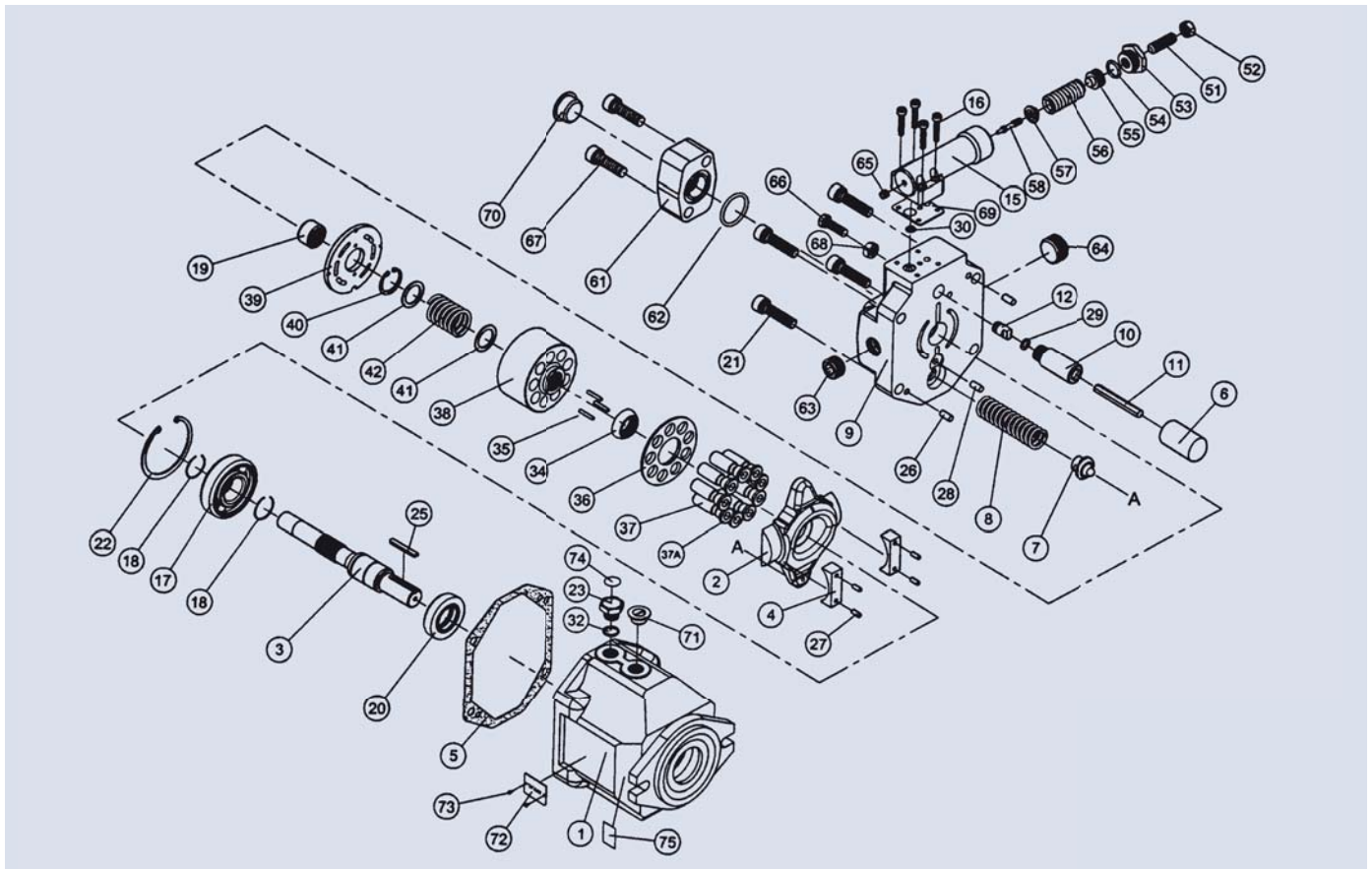

List of parts

No.	Description	No.	Description	No.	Description	No.	Description
1	Pump body	18	C snap ring 1-1/2	36	Slipper retainer	58	Control compensator shaft
2	Swash	19	1715 bearing rear	37	Piston	61	Flange 506A (6")
3	Swash shaft	20	Shaft seal	37A	Head of piston	62	O-ring G30
4	Swash plate	21	Screw M10x40L	38	Cylinder block	63	Pipe plug 1/2
5	Body seal	22	R62 snap ring	39	Valve plate	64	Pipe plug 3/4
6	Servo piston sleeve	23	Plug, feeder	40	Snap ring for bore R28	65	NPT 1/16
7	Servo spring washer	25	Key	41	Washer cylinder block	66	Screw M8x35
8	Swash spring	26	Locator pin, body	42	Retainer spring	67	Screw M10x35
9	Pump body / end cover	27	Locator pin, cradle	51	Screw M10x30	68	Lock nut M8
10	Sleeve piston	28	Locator pin, ø6x12.8	52	Lock nut M10	69	Body seal
11	Flow bar	29	O-ring P8 70°	53	Control lock nut	70	Plastic plug 3/4
12	Seal	30	O-ring P7	54	O-ring P14 70°	71	Plastic plug 3/8
15	Valve	32	O-ring S11	55	Control washer	72-73	Name Plate
16	Screw M5x25L	34	Cylinder block holder	56	Control spring	74-75	Description label
17	6305 bearing front	35	Roller	57	Spring washer		

PV SERIES AXIAL PISTON PUMP

FEATURES



1. New type of swash plate and large servo pistons with strong bias spring achieve fast response, reduce the noise due to active decompression of system at down stroke.
2. Nine piston and new precompression technology (precompression filter volume) result in unbeaten low outlet flow pulsation.
3. Rigid and FEM-optimized body design for lowest noise level.
4. Thru drive for 100% nominal torque.
5. Pump combinations (tandem pumps) of same size and model and mounting interface for basically all metric or SAE mounting interfaces.

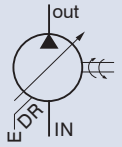

Continuous: 350bar
Intermittent: 420bar

B

Quick Reference Data Chart

Model	Displacement		Pump Delivery (7 bar) 100 PSI					
			1200 RPM		1500 RPM		1800 RPM	
	cc/rev	in ³ /rev	LPM	U.S. GPM	LPM	U.S. GPM	LPM	U.S. GPM
PV016	16	0.98	19.2	5.1	24	6.3	28.8	7.6
PV020	20	1.2	24	6.3	30	7.9	36	9.5
PV023	23	1.4	27.6	7.3	34.5	9.1	41.4	10.9
PV032	32	1.9	38.4	10.1	48	12.7	57.6	15.2
PV040	40	2.4	48	12.7	60	15.9	72	19
PV046	46	2.8	55.2	14.6	69	18.2	82.8	21.9
PV063	63	3.8	75.6	20	94.5	25	113.4	30
PV071	71	4.3	85.8	22.7	107	28.3	128.7	34
PV080	80	4.8	96	25.4	120	31.7	144	38
PV092	92	5.6	110.4	29.2	138	36.5	165.6	43.8
PV140	140	8.5	168	44.4	210	55.5	252.1	66.6
PV180	180	11	216	57.1	270	71.3	324	85.6
PV270	270	16.5	324	85.6	405	107	486	128.4

Model	APPROX. Noise Levels Db(A) Full Flow and 1500 RPM			Input Horse Power, Max. Displacement & 345 bar (5000PSI)		Operating Speed		Weight (kg)		
	70 bar (1 KPSI)	207 bar (3 KPSI)	343 bar (5 KPSI)	1500 rpm	1800 rpm	Max.	Min.	kg	lb	
				KW(hp)	KW(hp)	RPM	RPM			
PV016	56	60	68	15.5 (20.8)	18.5 (24.8)	2750	300	19	41.8	
PV020				19.5 (26.1)	23.4 (31.4)					
PV023				22.5 (30.2)	25.1 (33.6)					
PV032	59	62	69	31 (41.6)	35.1 (47.1)	2400	300	30	66	
PV040				39 (52.3)	46.5 (62.3)					
PV046				45 (60.3)	50.2 (67.3)					
PV063	66	70	74	61.5 (82.4)	70.1 (94)	2100	300	60	132	
PV071				70 (93.8)	80 (107.2)	2100				
PV080				78 (104.6)	89.2 (119.6)	2000				
PV092				89.5 (120)	136.8 (183.4)	1900				
PV140	70	74	76	136 (182.3)	149.4 (200.3)	2200	300	90	198	
PV180	71	75	77	175 (235)	210 (282)	2200		90	198	
PV270	77	79	81	263 (353)	298 (400)	1800		300	172	378.4

1. Installation outlet port top, the pipe have to less than 2 bar.
2. The use of max. pressure override 6 min, hydraulic oil clean that see General Installation Information.
3. Hydrome offer tandem pumps, and other pumps connection, the connection type use metric version and SAE version dimensions.

PV SERIES AXIAL PISTON PUMP

How to order

PV - 063 - GT - R - M - 1 - A - ✱ - ✱ - ✱

1 2 3 4 5 6 7 8 9 10

1 Series Axial piston pump variable displacement high pressure version

2 Size and Displacement

Code	Displacement cc/rev (In ³ /rev)	Code	Displacement cc/rev (In ³ /rev)	Code	Displacement cc/rev (In ³ /rev)
016	16 (0.98)	046	46 (2.8)	140	140 (8.5)
020	20 (1.2)	063	63 (3.8)	180	180 (10.9)
023	23 (1.4)	071	71 (4.3)	270	270 (16.5)
032	32 (1.9)	080	80 (4.8)		
040	40 (2.4)	092	92 (5.6)		

3 Control Types

Code	Compensator	Code	Horse power	PV016~ PV023	PV032~ PV046	PV063~ PV092	PV140	PV180	PV270
✱	Standard Type Pressure Compensator	A	3 KW	●					
	A2 10~140 bar	B	4 KW	●					
	A3 40~210 bar	C	5.5 KW	●	●				
	A4 70~350 bar	D	7.5 KW	●	●				
✱	Remote Type	E	11 KW	●	●	●			
✱	GT Remote pressure compensator	F	15 KW		●	●			
✱	GM Remote pressure compensator allows a pilot valve	G	18.5 KW		●	●	●		
	GA Remote pressure compensator allows a pilot valve (valve included)	H	22 KW		●	●	●	●	
	GJ Layer proportional pressure compensator (valve included)	I	30 KW			●	●	●	
	Electrical Unloading Type	J	37 KW			●	●	●	●
	GR Electrical unloading	K	45 KW			●	●	●	●
	GB Dual pressure control	L	55 KW				●	●	●
	GC Dual pressure+electrical unloading	M	75 KW					●	●
	Load-sensing Type	N	90 KW					●	●
✱	HL Load-sensing type	O	110 KW						●
	HM Load-sensing type	P	132 KW						●
	HJ 2-valve load-sensing type (valve included)								
	HA 2-valve load-sensing type								
	HK Proportional electro-hydraulic load sensing type								
	HQ Load-sensing & Proportional flow control								
	Proportionable displacement Type								
	FV Proportionable displacement control								
	FR Proportionable displacement control with pressure								
	FG Proportionable displacement control with pressure control								
	Horse Power Type								
	PA <input type="checkbox"/> Horse power compensator								
✱	PM <input type="checkbox"/> Horse power compensator, pilot flow internal pressure pilot valve (valve included)								
	PG <input type="checkbox"/> Horse power compensator, pilot flow internal								
	PL <input type="checkbox"/> Horse power compensator, load-sensing compensator								
	PH <input type="checkbox"/> Horse power compensator, pilot flow external for load-sensing								

4 Rotation (Viewed from shaft end)

Code	Rotation
✱ R	clockwise ↻
L	counterclockwise ↺



PV SERIES AXIAL PISTON PUMP

How to order

PV - 063 - GT - R - M - 1 - A - ※ - ※ - ※

1 2 3 4 5 6 7 8 9 10

5 Mounting

Code	Mounting	Code	Mounting
※ M (standard)	Metric	N	Inch
K		D	

Code	Model	Shaft		Flange		Mounting	
		A	B	C	D	E	
※ M	Metric	PV016~PV023	ø25	8×7×40	ø100	9	ø125
		PV032~PV046	ø32	10×8×56	ø125	9	ø160
		PV063~PV092	ø40	12×8×80	ø160	9	ø200
		PV140~PV180	ø50	12×8×80	ø160	9	ø200
		PV270	ø65	12×8×80	ø200	9	ø250
K	Metric	PV016~PV023	W25×1.5×15×8f DIN5480		ø100	9	ø125
		PV032~PV046	W32×1.5×20×8f DIN5480		ø125	9	ø160
		PV063~PV092	W40×1.5×25×8f DIN5480		ø160	9	ø200
		PV140~PV180	W50×2×24×9g DIN5480		ø160	9	ø200
		PV270	W60×2×28×9g DIN5480		ø200	9	ø250
N	Inch	PV016~PV023	ø1"	0.25"×0.25"×1.6"	ø4"	3/8"	ø5"
		PV032~PV046	ø1-1/4"	5/16"×5/16"×2.2"	ø5"	1/2"	ø6.37"
		PV063~PV092	ø1-3/4"	7/16"×7/16"×3.15"	ø6"	1/2"	ø9"
		PV140~PV180	ø2"	1/2"×1/2"×2.95"	ø6"	1/2"	ø9"
		PV270	ø2"	1/2"×1/2"×2.95"	ø6.5"	5/8"	ø12.5"
D	Inch	PV016~PV023	Splined 15T 16/32DP ANSI B92.1		ø4"	3/8"	ø5"
		PV032~PV046	Splined 14T 12/24DP ANSI B92.1		ø5"	1/2"	ø6.37"
		PV063~PV092	Splined 13T 8/16DP ANSI B92.1		ø6"	1/2"	ø9"
		PV140~PV180	Splined 15T 8/16DP ANSI B92.1		ø6"	1/2"	ø9"
		PV270	Splined 15T 8/16DP ANSI B92.1		ø6.5"	5/8"	ø12.5"

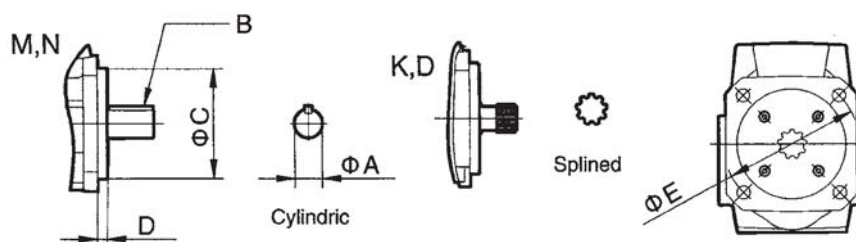

6 Threads

Code	Threads
※ 1 (standard)	BSPP (G)
2	PT (RC)
3	UNF
4	NPT
7	ISO 6149

PV SERIES AXIAL PISTON PUMP

How to order

PV - 063 - GT - R - M - 1 - A - *-*-*

1 2 3 4 5 6 7 8 9 10

7 Thru drive & 2nd pump

Code	Thru drive & 2nd pump	
* A (standard)	Single pump	
* B	Prepared for thru drive	
With adaptor for 2nd pump		
C	Inch	SAE AA, $\phi 2"$ ($\phi 50.8\text{mm}$)
D		SAE A, $\phi 3-1/4"$ ($\phi 82.55\text{mm}$)
E		SAE B, $\phi 4"$ ($\phi 101.6\text{mm}$)
F		SAE C, $\phi 5"$ ($\phi 127\text{mm}$)
G		SAE D, $\phi 6"$ ($\phi 152.4\text{mm}$)
H		SAE E, $\phi 6.5"$ ($\phi 165.1\text{mm}$)
I	Metric	Metric, $\phi 63$
J		Metric, $\phi 80$
K		Metric, $\phi 100$
L		Metric, $\phi 125$
M		Metric, $\phi 160$
N		Metric, $\phi 200$
Other pump are acceptable order		

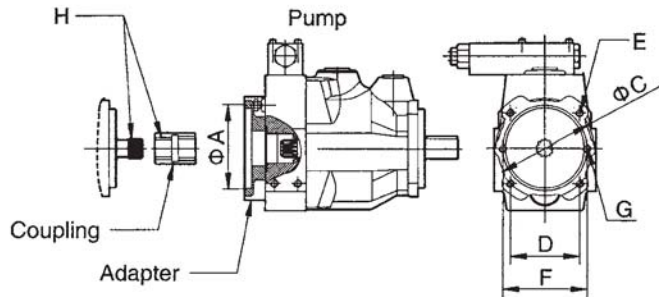

Code	Model	ϕA	ϕC	D	E	F	G	H
C	SAE AA, $\phi 2"$ ($\phi 50.8\text{mm}$)	$\phi 2"$ ($\phi 50.8$)				3.25" (82.55mm)	5/16"-18	9T 20/40 DP
D	SAE A, $\phi 3-1/4"$ ($\phi 82.55\text{mm}$)	$\phi 3-1/4"$ ($\phi 82.55$)				4.188" (106.3mm)	3/8"-16	9T 16/32 DP
E	SAE B, $\phi 4"$ ($\phi 101.6\text{mm}$)	$\phi 4"$ ($\phi 101.6$)		3.536" (89.8mm)	1/2"-13	5.75" (146.05mm)	1/2"-13	13T 16/32 DP, 15T 16/32 DP
F	SAE C, $\phi 5"$ ($\phi 127\text{mm}$)	$\phi 5"$ ($\phi 127$)		4.508" (114.5mm)	1/2"-13	7.125" (180.98mm)	5/8"-11	14T 12/24 DP, 15T 16/32 DP
G	SAE D, $\phi 6"$ ($\phi 152.4\text{mm}$)	$\phi 6"$ ($\phi 152.4$)		6.364" (161.6mm)	5/8"-11	9" (228.6mm)	5/8"-11	13T 8/16 DP, 15T 8/16 DP
H	SAE E, $\phi 6.5"$ ($\phi 165.1\text{mm}$)	$\phi 6.5"$ ($\phi 165.1$)		8.839" (224.5mm)	3/4"-10			15T 8/16 DP
I	Metric, $\phi 63$	$\phi 63$	$\phi 85$		M8	100	M8	
J	Metric, $\phi 80$	$\phi 80$	$\phi 103$		M8	109	M10	
K	Metric, $\phi 100$	$\phi 100$	$\phi 125$		M10	150	M12	W25×1.5×15×8f
L	Metric, $\phi 125$	$\phi 125$	$\phi 160$		M12	180	M16	W32×1.5×20×8f
M	Metric, $\phi 160$	$\phi 160$	$\phi 200$		M16	224	M20	W40×1.5×25×8f, W50×2×24×9g
N	Metric, $\phi 200$	$\phi 200$	$\phi 250$		M20			W50×2×24×9g

Coupling pump				Coupling pump				Coupling pump			
Code	pump	H		Code	pump	H		Code	pump	H	
A-D1	PV016~ PV023	D1	9T 20/40 DP	C-D5	PV063~ PV092	D5	14T 12/24 DP	D-W2	PV140~ PV180	W2	W32×1.5×20×8f
A-D2		D2	9T 16/32 DP	C-D6		D6	13T 8/16 DP	D-W3		W3	W40×1.5×25×8f
A-D3		D3	13T 16/32 DP	C-D7		D7	15T 8/16 DP	D-W4		W4	W50×2×24×9g
A-D4		D4	15T 16/32 DP	C-W1		W1	W25×1.5×15×8f	E-D2		D2	9T 16/32 DP
A-W1	PV032~ PV046	W1	W25×1.5×15×8f	C-W2	W2	W32×1.5×20×8f	E-D3	D3	13T 16/32 DP		
B-D2		D2	9T 16/32 DP	C-W3	W3	W40×1.5×25×8f	E-D4	D4	15T 16/32 DP		
B-D3		D3	13T 16/32 DP	C-W4	W4	W50×2×24×9g	E-D5	D5	14T 12/24 DP		
B-D4		D4	15T 16/32 DP	D-D2	D2	9T 16/32 DP	E-D6	D6	13T 8/16 DP		
B-D5	D5	14T 12/24 DP	D-D3	D3	13T 16/32 DP	E-D7	D7	15T 8/16 DP			
B-W1	PV063~ PV092	W1	W25×1.5×15×8f	D-D4	D4	15T 16/32 DP	E-W1	W1	W25×1.5×15×8f		
B-W2		W2	W32×1.5×20×8f	D-D5	D5	14T 12/24 DP	E-W2	W2	W32×1.5×20×8f		
C-D2		D2	9T 16/32 DP	D-D6	D6	13T 8/16 DP	E-W3	W3	W40×1.5×25×8f		
C-D3		D3	13T 16/32 DP	D-D7	D7	15T 8/16 DP	E-W4	W4	W50×2×24×9g		
C-D4	D4	15T 16/32 DP	D-W1	W1	W25×1.5×15×8f	E-W5	W5	W60×2×28×9g			

8 Voltage

Code	Voltage	Code	Voltage	Code	Voltage
0	None	C	AC200V (50-60Hz)	F	DC24V
A	AC100V (50-60Hz)	D	AC220V (60Hz)		
B	AC110V (60Hz)	E	DC12V		

9 Seals

Code	Seals	Code	Seals
* N	NBR	E	Ethylene-propylen
V	FPM		

10 Design No. Not require for order

PV SERIES AXIAL PISTON PUMP

Compensator

Standard Type

- A:** Standard pressure compensator remote type
- GT:** Remote pressure compensator
- GM:** Remote pressure compensator allows a pilot valve
- GA:** Remote pressure compensator allows a pilot valve (valve included)
- GJ:** Layer proportional pressure compensator (valve included)

Electrical Unloading Type

- GR:** Electrical unloading
- GB:** 2 pressure electrical selection
- GC:** 2 pressure + electrical unloading

Load-sensing Type

- HL:** Load-sensing compensator
- HM:** Load-sensing compensator
- HJ:** 2-valve load-sensing compensator
- HA:** 2-valve load-sensing compensator (valve included)
- HK:** Proportional electro-hydraulic load sensing type
- HQ:** Load-sensing & Proportional flow control

Horse Power Type

- PA:** Horse power compensator
- PM:** Horse power compensator, pilot flow internal pressure pilot valve included
- PG:** Horse power compensator, pilot flow internal
- PL:** Horse power compensator, Load-sensing compensator
- PH:** Horse power compensator, pilot flow external for load-sensing

A: Standard Pressure compensator

The standard pressure compensator adjusts the pump displacement according to the actual need of the system in order to keep the pressure constant. As long as the system pressure at outlet port P is lower than the set pressure (set as spring preload of the compensator spring) the working port A of the compensator valve is connected to the case drain and the piston area is unloaded. Bias spring and system pressure on the annulus area keep the pump at full displacement.

When the system pressure reaches the set pressure the compensator valve spool connects port P1 to A and builds up a pressure at the servo piston resulting in a down stroking of the pump. The displacement of the pump is controlled in order to match the flow requirement of the system.

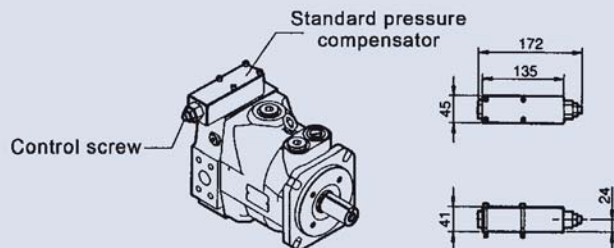
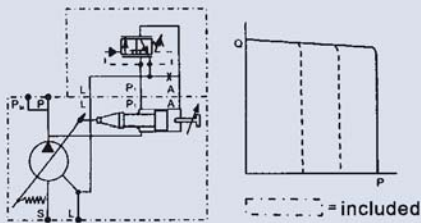

GT: Remote Pressure compensator

While at the standard pressure compensator the pressure is set directly at the compensator spring, the setting of the remote pressure compensator can be achieved by any suitable pilot pressure valve connected to pilot port PP. The pilot flow supply is internal through the valve spool.

The pilot flow is 1-1.5 lpm. The pilot valve can be installed remote from the pump in some distance. That allows pressure setting e.g. from the control panel of the machine. The remote pressure compensator and is able to solve instability problems that may occur with a standard pressure compensator in critical applications. The pressure pilot valve can also be electronically controlled (proportional pressure valve) or combined with a directional control valve for low pressure standby operation.

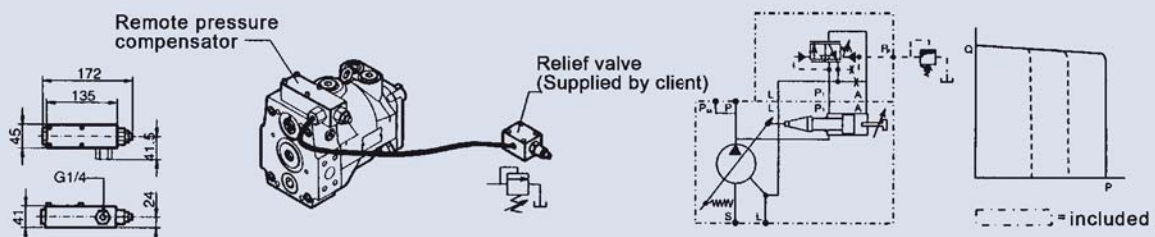

PV SERIES AXIAL PISTON PUMP

Compensator

Remote Pressure compensator allows pilot valve

Version GM of remote pressure compensator provides on its top side an interface NG6, DIN24340 (CETOP 03 at RP35H, NFFA D03). This interface allows a direct mounting of a pilot valve. Beside manual or electro hydraulic operated valves it is also possible to mount complete multiple pressure circuits directly on the compensator body. HYDROME

offers a variety of these compensator accessories ready to install. All remote pressure compensator have a factory setting of 15 bar differential pressure. With this setting, the controlled pressure at the pump outlet is higher than the pressure controlled by the pilot valve.

GM: Remote Pressure compensator allows a pilot valve

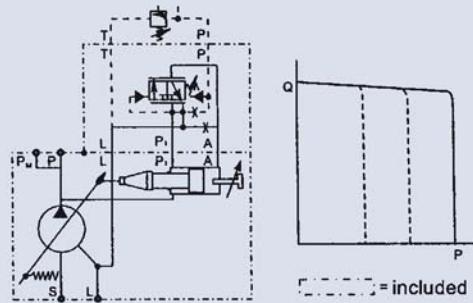
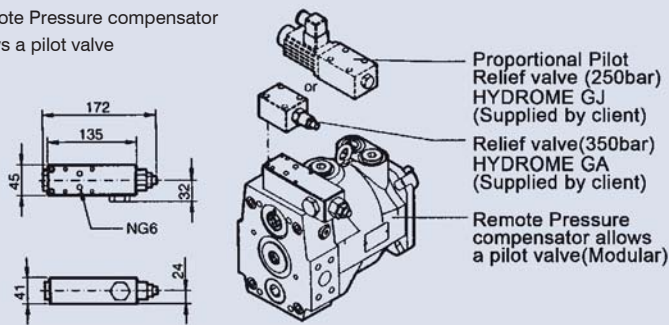

GA: Remote Pressure compensator allows a pilot valve (valve included)

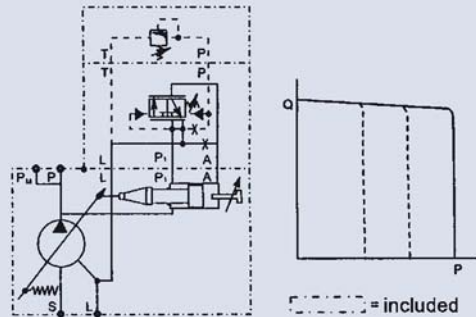
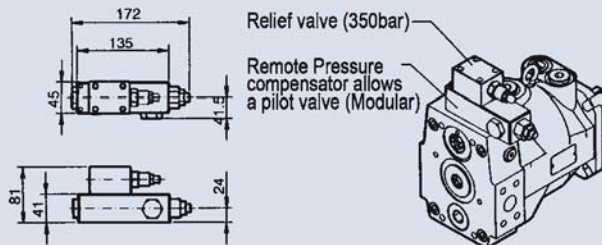

GJ: Layer Proportional pressure compensator (valve included)

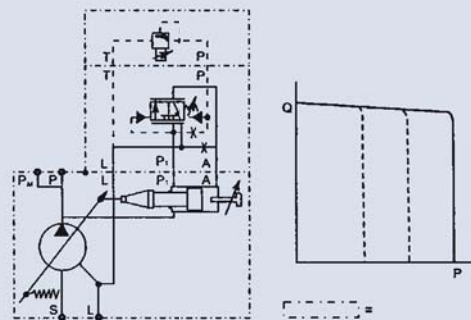
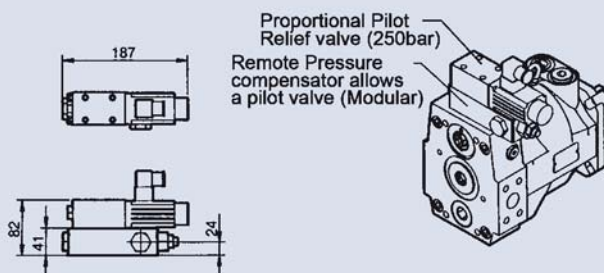

PV SERIES AXIAL PISTON PUMP

Compensator

Electrical Unloading Type

PV pump with fast response remote pressure control, relief valve with 2 pressure stages, electrical pressure selection, nitrile seals, spindle adjustment, 24 VDC solenoid, plug to DIN46350 accessories fitted.

Usable for horsepower control and proportional volume control, too.

GR: Electrical unloading type

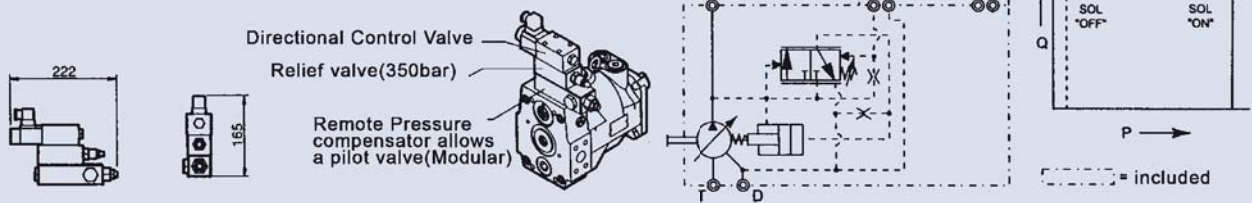

GB: Dual pressure control

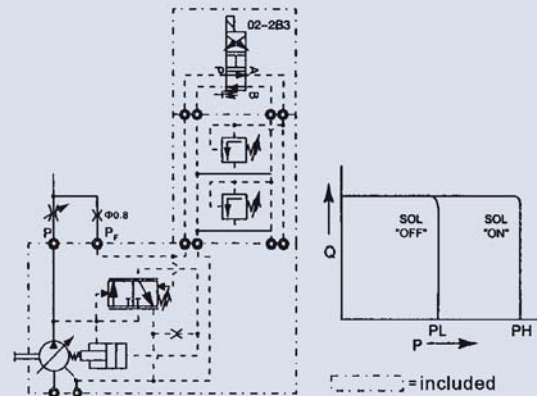
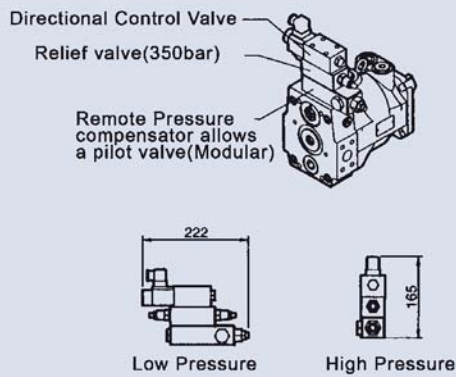

GC: Dual pressure + electrical unloading

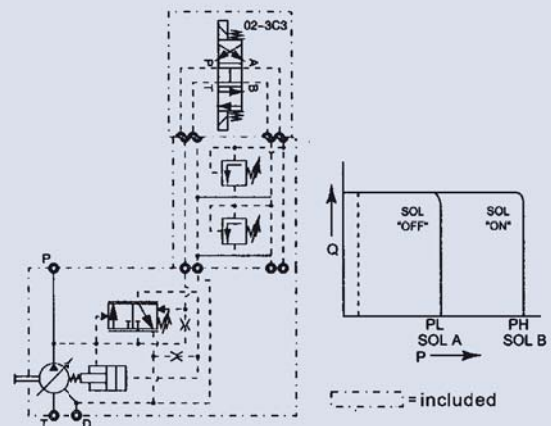
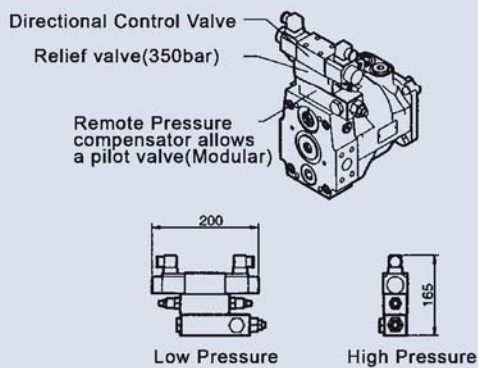

PV SERIES AXIAL PISTON PUMP

Compensator

Load-sensing Type

HL: Load-sensing compensator

The load-sensing compensator has an external pilot pressure supply. Factory setting for the differential pressure is 10 bar. The input signal to the compensator is the differential pressure at a main stream resistor. A load-sensing compensator represents mainly a flow control for the pump output flow, because the compensator keeps

the pressure drop at the main stream resistor constant. A variable input speed or a varying load (pressure) has consequently no influence on the output flow of the pump and speed of the actuator. By adding a pilot orifice ($\varnothing 0.8\text{mm}$) and compensation can be added to the flow control function. See the circuit diagram below, left.

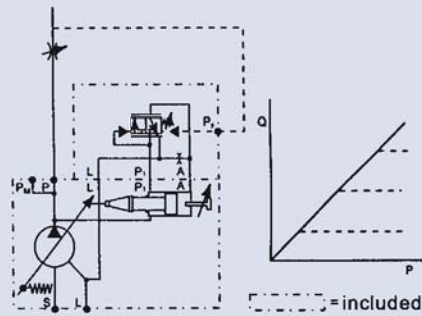
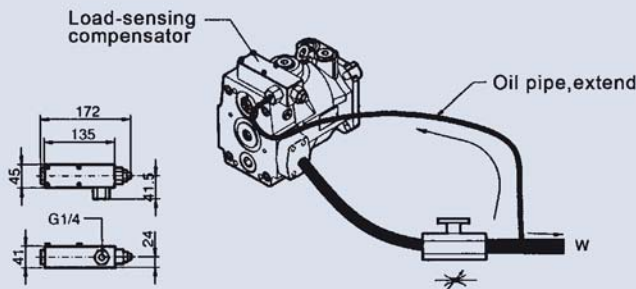

HM: Load-sensing compensator

Shown above is load sensing compensator code HM with an NG6 interface on top of the control valve. That allows direct mounting of a pilot valve for pressure compensation. This version includes the pilot orifice. Due to the interaction of flow and pressure compensation

this package has not the "ideal" control characteristic. The deviation is caused by the pilot valves characteristic.

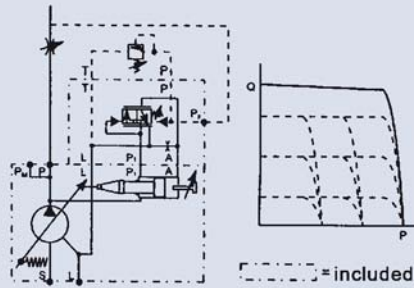
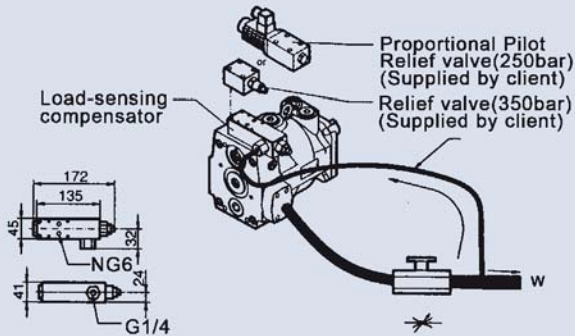

HJ: 2-valve load-sensing compensator

If a more accurate pressure compensation is required, the 2-valve load-sensing compensator code HJ can be used. The circuit diagram of this version is shown left. Here the interaction of the two control

functions is avoided by using two separate control valves for flow and pressure compensation. The 2-valve compensator is equipped with an interface NG6 on the compensators top side.

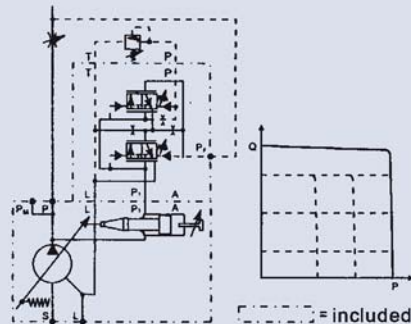
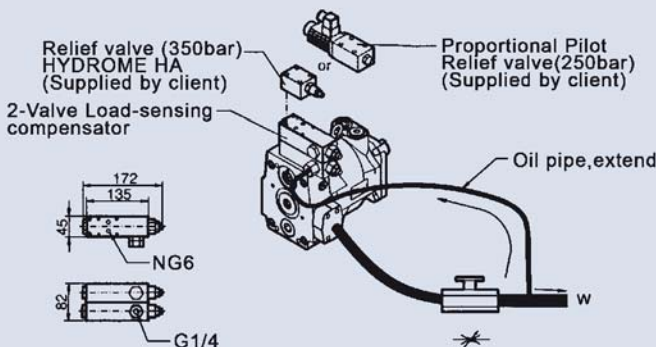

PV SERIES AXIAL PISTON PUMP

Compensator

HA: 2-valve load-sensing compensator (valve included)

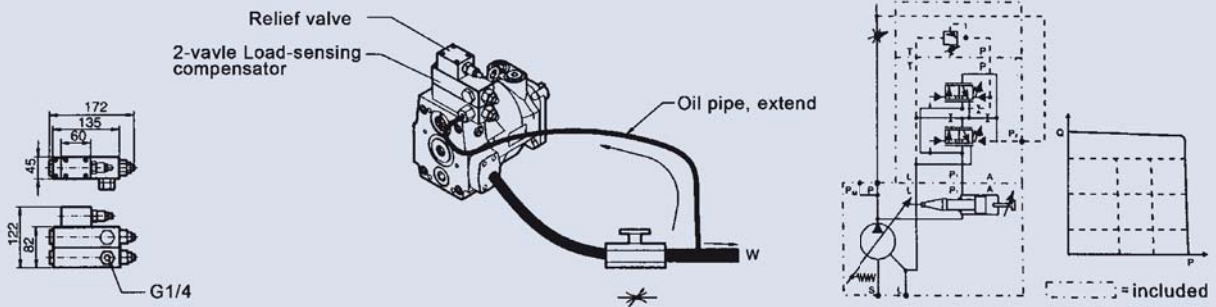

The hydraulic-mechanical horse power compensator consists of a modified remote pressure compensator (Code PG* \ PM*) or of a modified load-sensing compensator (Code PH*) and a pilot valve. This pilot valve is integrated into the pump and is adjusted by a cam sleeve. The cam sleeve has a contour that is designed and machined for the individual displacement and the nominal horse power setting. At a large displacement the opening pressure (given by the cam sleeve diameter) is lower than at small displacements. This makes the pump compensate along a constant horse power (torque) curve.

For all nominal powers of standard electrical motors HYDROME offers a dedicated cam sleeve. The exchange of this cam sleeve (e. g. : to change horse power setting) can easily be done without disassembly of the pump.

On top of that an adjustment of the horse power setting can be done within certain limits by adjustment the preload of the pilot control cartridge spring.

That allows an adjustment of a constant horse power setting for other than the nominal speeds (1500min-1) or for other horse power.

PA: Horse power compensator

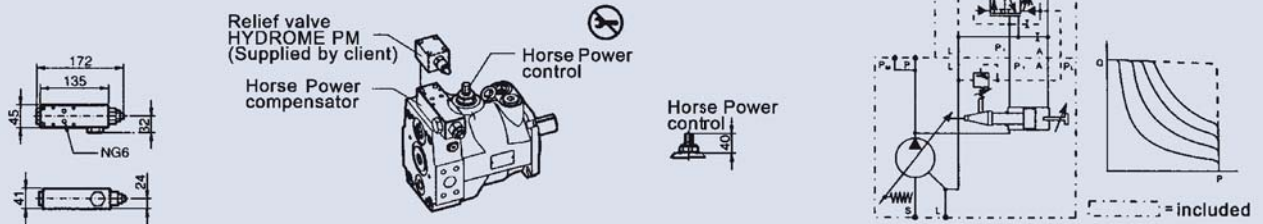

PM: Horse power compensator, pilot flow internal pressure pilot valve included

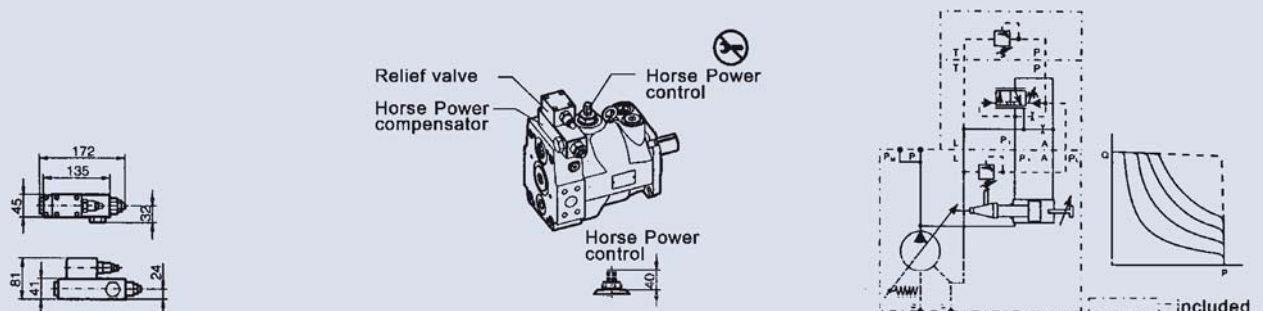

PV SERIES AXIAL PISTON PUMP

Compensator

PG: Horse power compensator, pilot flow internal

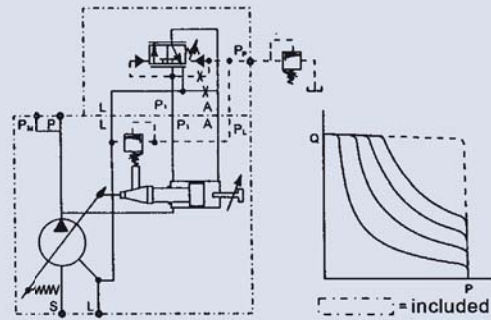
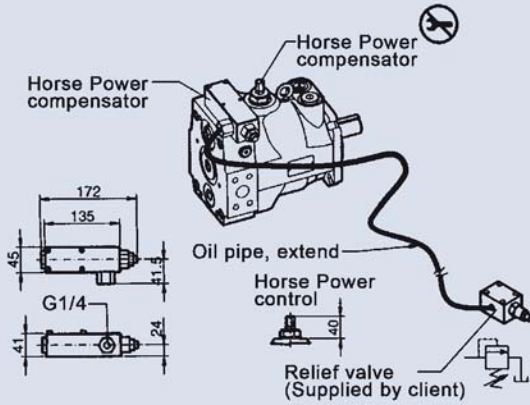

PL: Horse power compensator, Load-sensing compensator

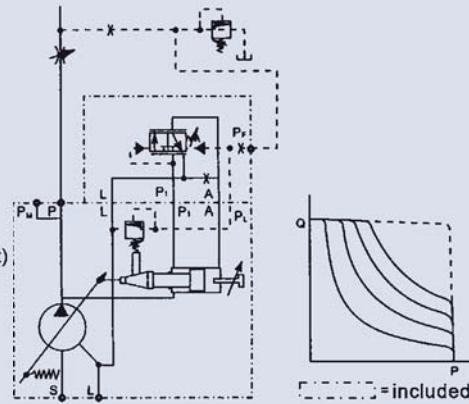
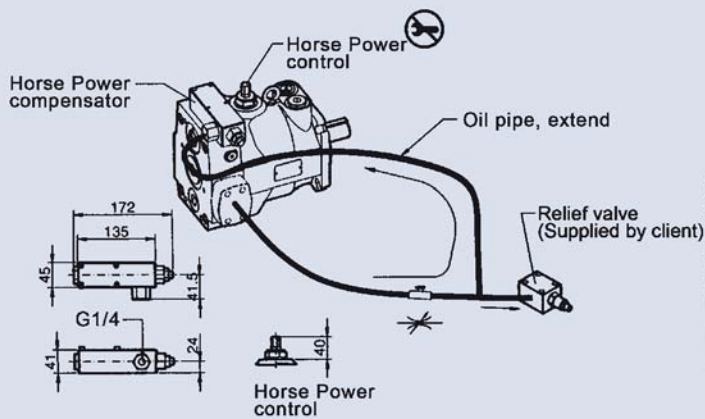

PH: Horse power compensator, pilot flow external for load-sensing

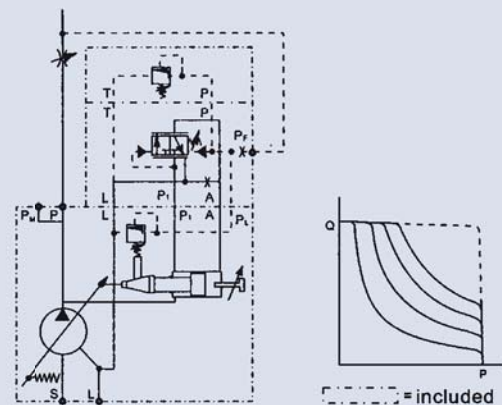
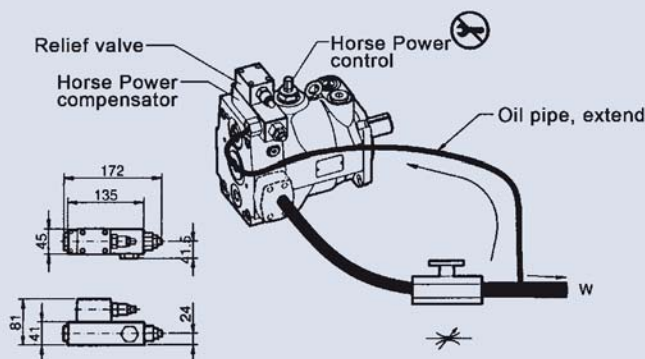

PV SERIES AXIAL PISTON PUMP

Performance curves

Horse Power Compensator, diagrams

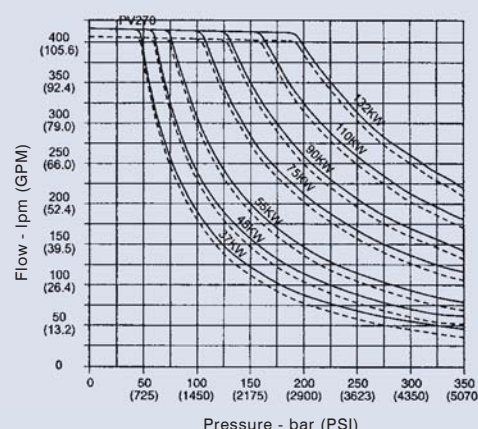
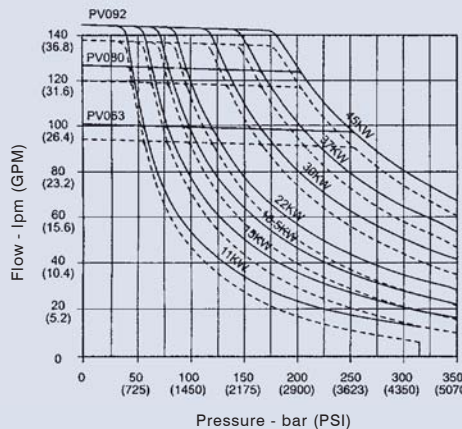
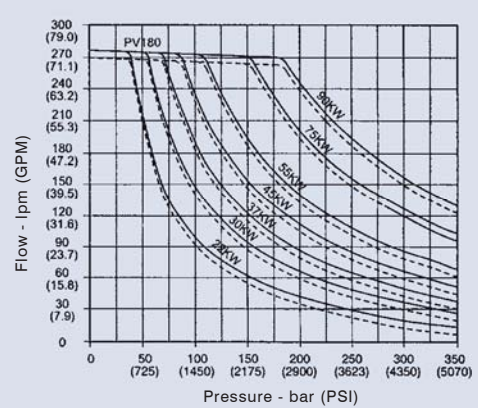
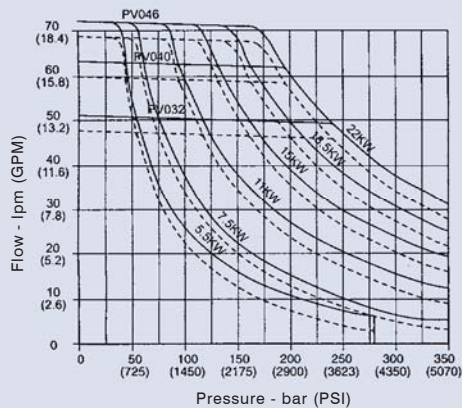
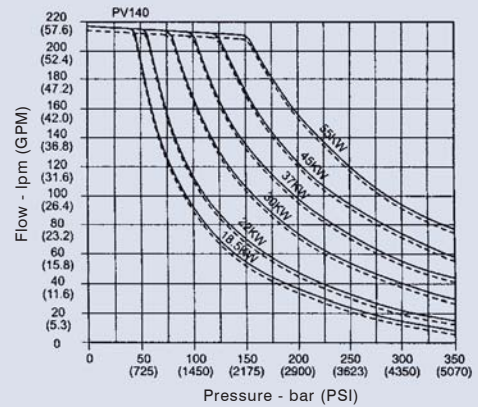
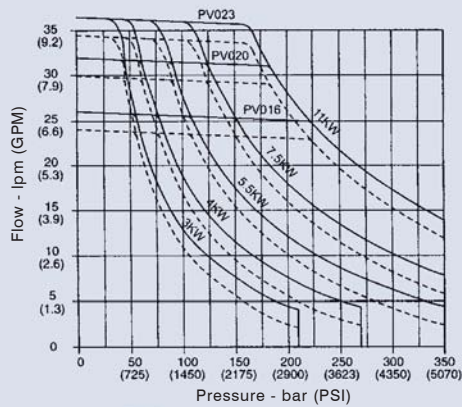

The diagrams shown are only valid for the following working conditions:
 speed: $n=1500$ (—) and 1800 (---) rev/min
 temperature: $t=50^{\circ}\text{C}$
 fluid: mineral oil HLP, ISO VG46
 viscosity: $v=46\text{mm}^2/\text{s}$ at 40°C

PV SERIES AXIAL PISTON PUMP

Efficiency And Case Drain Flows PV016-PV023

The efficiency and power graphs are measured at an input speed of $n = 1500 \text{ min}^{-1}$, a temperature of 40°C and a fluid viscosity of $46 \text{ mm}^2/\text{s}$. Case drain flow and compensator control flow leave via the drain port of the pump. To the valves shown are to be added 1 to 1.2 lpm, if at pilot operated compensator (code G*, H* horse power compensator and P/Q-control) the control flow of the pressure pilot valve also goes

through the pump.

Please note: The valves shown below are only valid for static operation. Under dynamic conditions and at rapid compensator of the pump the volume displaced by the servo piston also leaves the case drain port.

This dynamic control flow can reach up to 40 lpm.

Therefore the case drain line is to lead to the reservoir at full size and without restrictions at short and direct as possible.

Performance curves

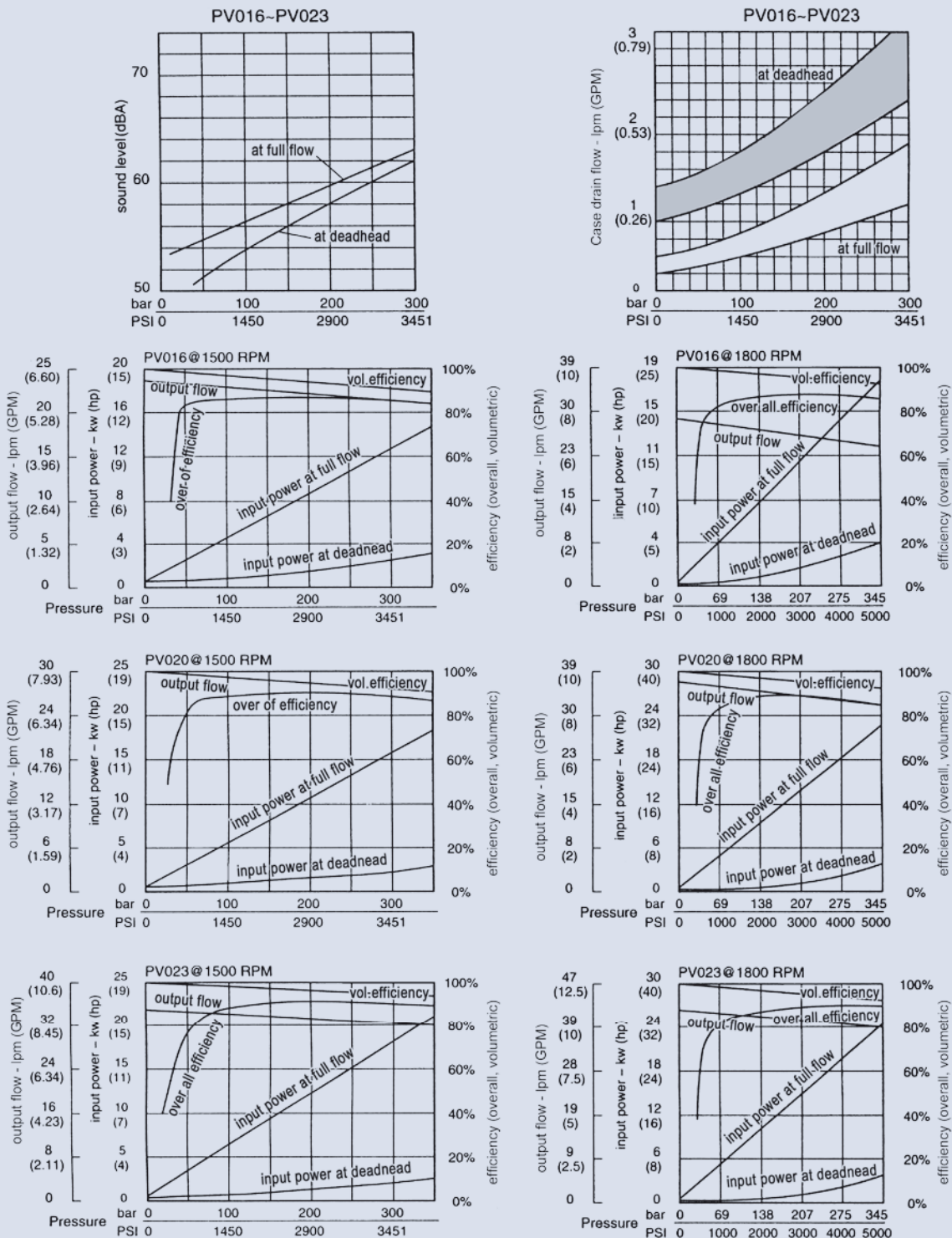

PV SERIES AXIAL PISTON PUMP

Efficiency And Case Drain Flows PV032-PV046

The efficiency and power graphs are measured at an input speed of $n = 1500 \text{ min}^{-1}$, a temperature of 40°C and a fluid viscosity of $46 \text{ mm}^2/\text{s}$. Case drain flow and compensator control flow leave via the drain port of the pump. To the valves shown are to be added 1 to 1.2 lpm, if at pilot operated compensator (code G*,H* horse power compensator and P/Q-control) the control flow of the pressure pilot valve also goes

through the pump.

Please note: The valves shown below are only valid for static operation. Under dynamic conditions and at rapid compensator of the pump the volume displaced by the servo piston also leaves the case drain port.

This dynamic control flow can reach up to 60 lpm.

Therefore the case drain line is to lead to the reservoir at full size and without restrictions at short and direct as possible.

Performance curves

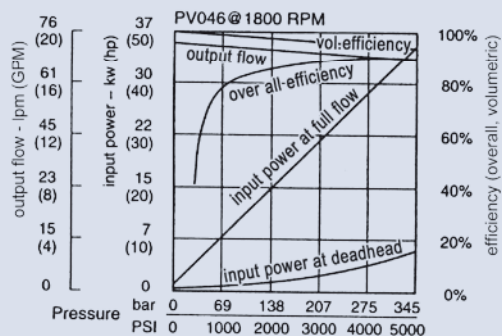
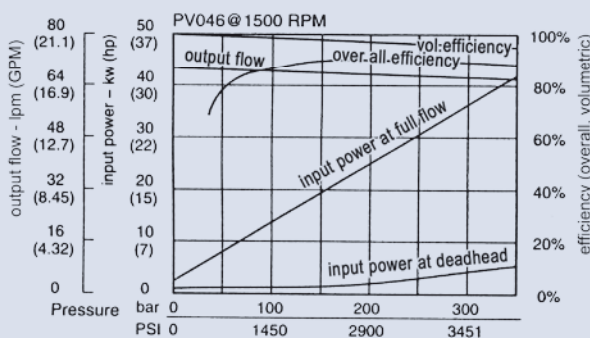
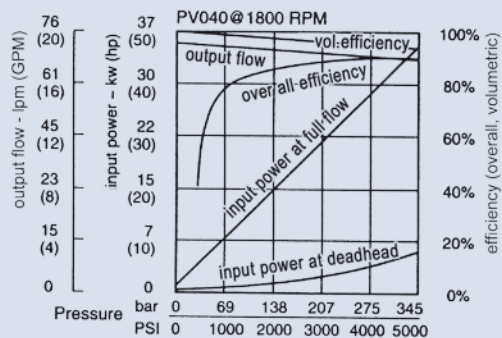
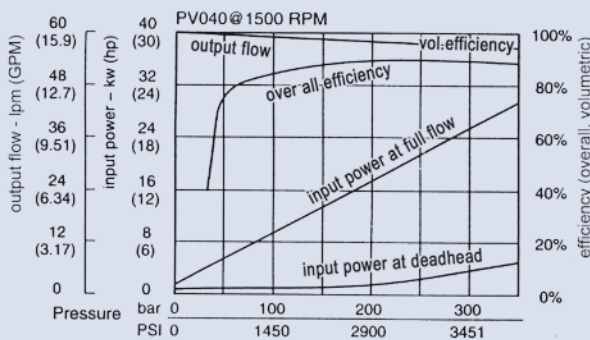
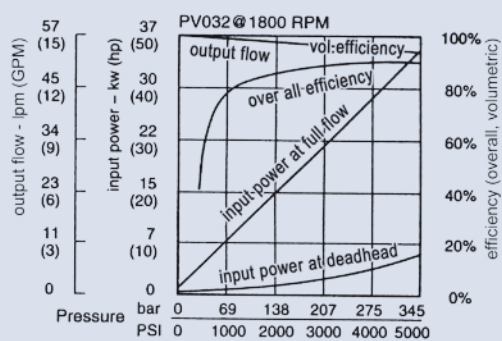
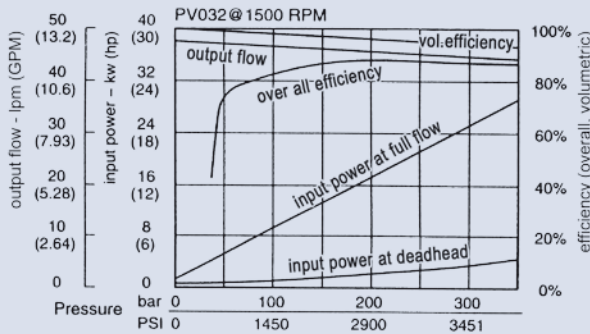
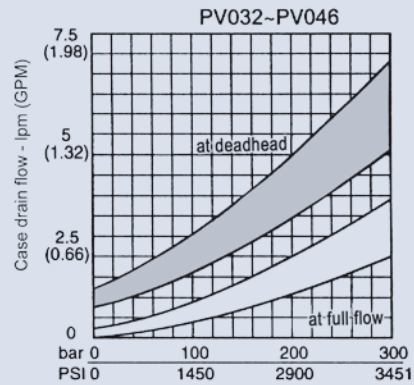
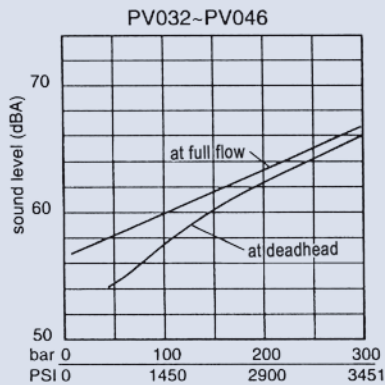

PV SERIES AXIAL PISTON PUMP

Efficiency And Case Drain Flows

PV063, PV080, PV092

The efficiency and power graphs are measured at an input speed of $n = 1500 \text{ min}^{-1}$, a temperature of 40°C and a fluid viscosity of $46 \text{ mm}^2/\text{s}$. Case drain flow and compensator control flow leave via the drain port of the pump. To the valves shown are to be added 1 to 1.2 lpm, if at pilot operated compensator (code G*, H* horse power compensator and P/Q-control) the control flow of the pressure pilot valve also goes

through the pump.

Please note: The valves shown below are only valid for static operation. Under dynamic conditions and at rapid compensator of the pump the volume displaced by the servo piston also leaves the case drain port.

This dynamic control flow can reach up to 80 lpm.

Therefore the case drain line is to lead to the reservoir at full size and without restrictions at short and direct as possible.

Performance curves

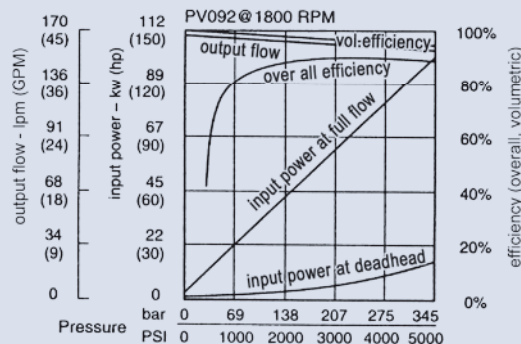
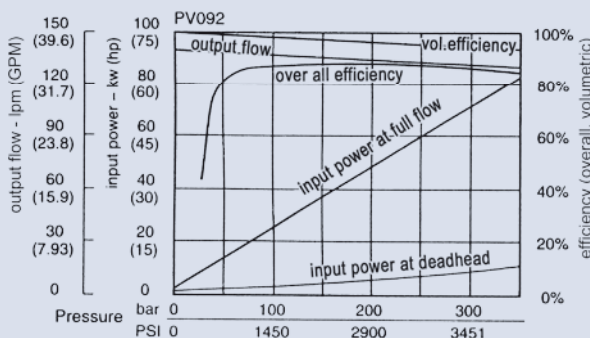
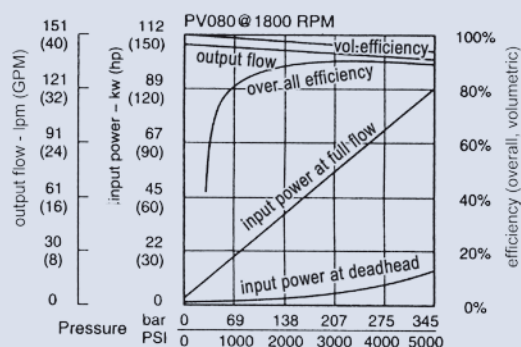
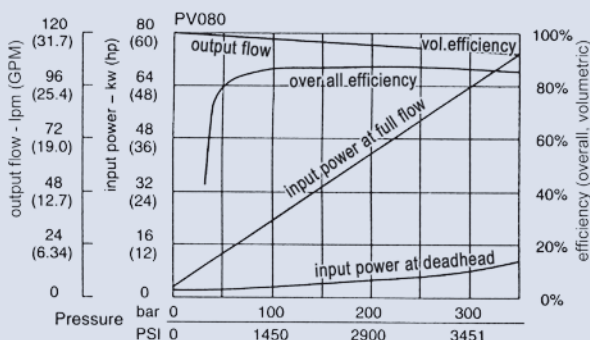
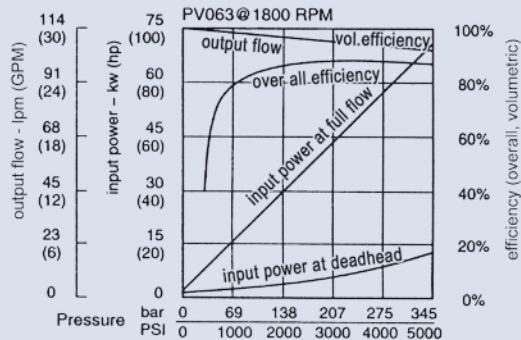
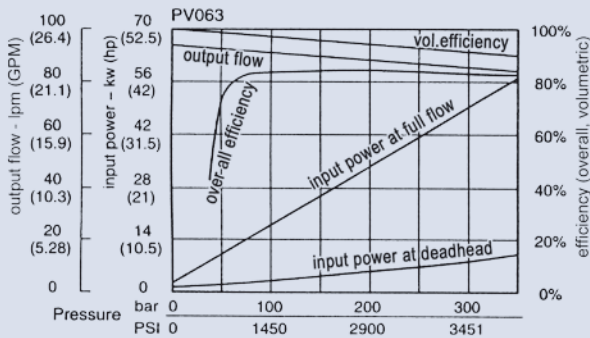
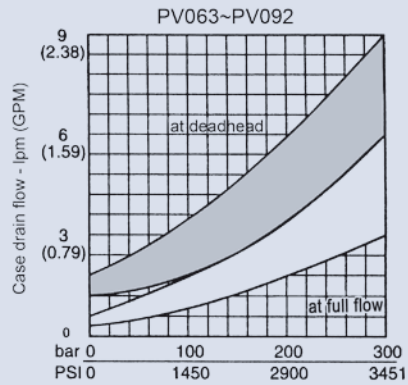
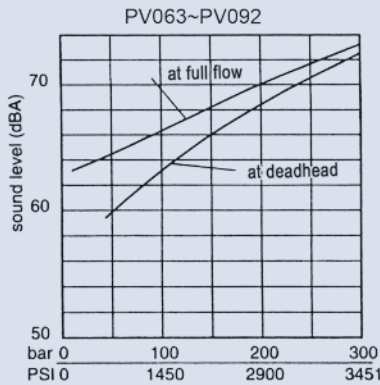

PV SERIES AXIAL PISTON PUMP

Efficiency And Case Drain Flows PV140, PV180

The efficiency and power graphs are measured at an input speed of $n = 1500 \text{ min}^{-1}$, a temperature of 40°C and a fluid viscosity of $46 \text{ mm}^2/\text{s}$. Case drain flow and compensator control flow leave via the drain port of the pump. To the valves shown are to be added 1 to 1.2 lpm, if at pilot operated compensator (code G*, H* horse power compensator and P/Q-control) the control flow of the pressure pilot valve also goes

through the pump.

Please note: The valves shown below are only valid for static operation. Under dynamic conditions and at rapid compensator of the pump the volume displaced by the servo piston also leaves the case drain port.

This dynamic control flow can reach up to 120 lpm.

Therefore the case drain line is to lead to the reservoir at full size and without restrictions at short and direct as possible.

Performance curves

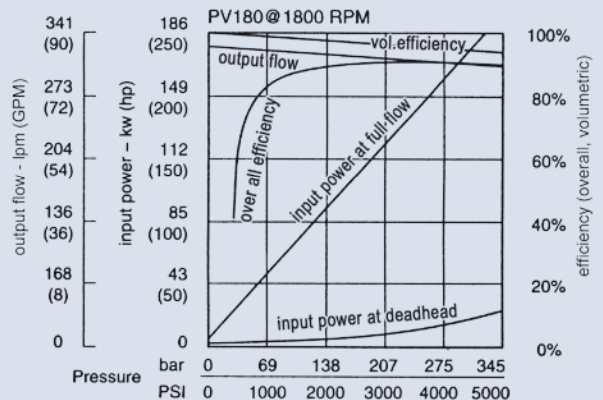
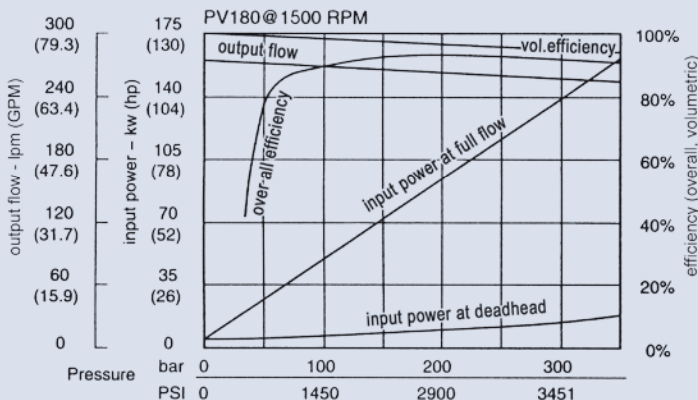
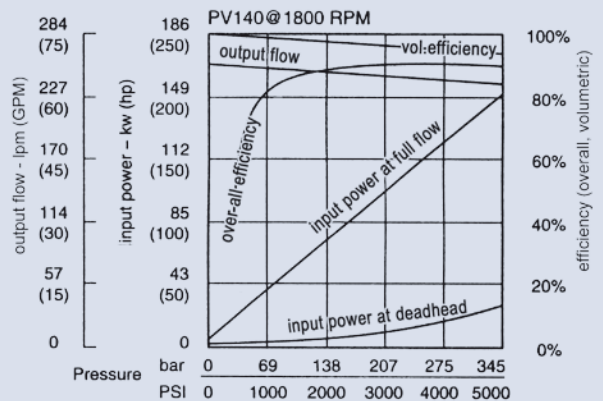
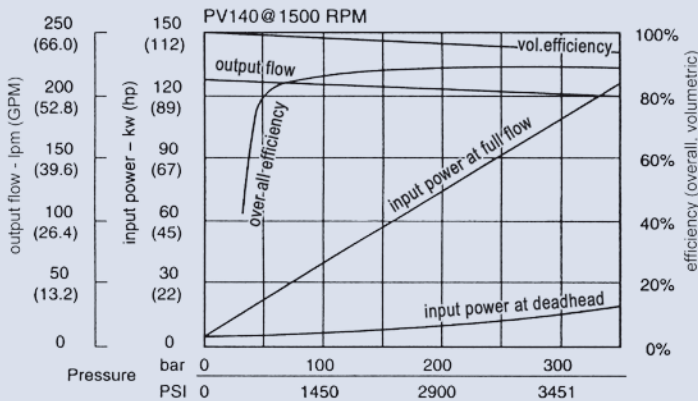
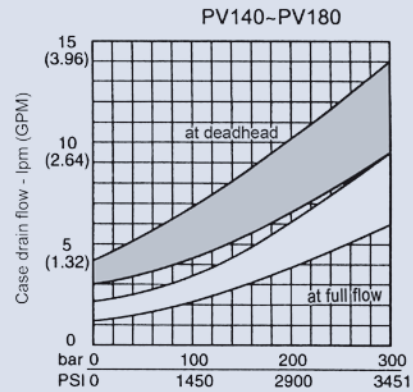
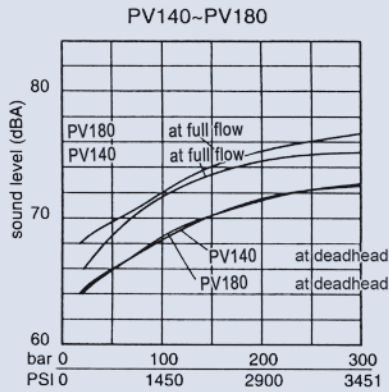

PV SERIES AXIAL PISTON PUMP

Efficiency And Case Drain Flows

PV270

The efficiency and power graphs are measured at an input speed of $n = 1500 \text{ min}^{-1}$, a temperature of 40°C and a fluid viscosity of $46 \text{ mm}^2/\text{s}$. Case drain flow and compensator control flow leave via the drain port of the pump. To the valves shown are to be added 1 to 1.2 lpm, if at pilot operated compensator (code G*, H* horse power compensator and P/Q-control) the control flow of the pressure pilot valve also goes

through the pump.

Please note: The valves shown below are only valid for static operation. Under dynamic conditions and at rapid compensator of the pump the volume displaced by the servo piston also leaves the case drain port.

This dynamic control flow can reach up to 120 lpm.

Therefore the case drain line is to lead to the reservoir at full size and without restrictions at short and direct as possible.

Performance curves

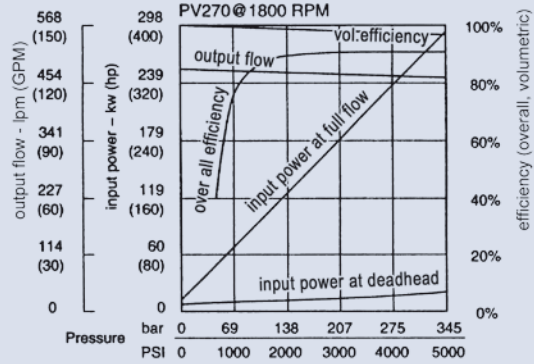
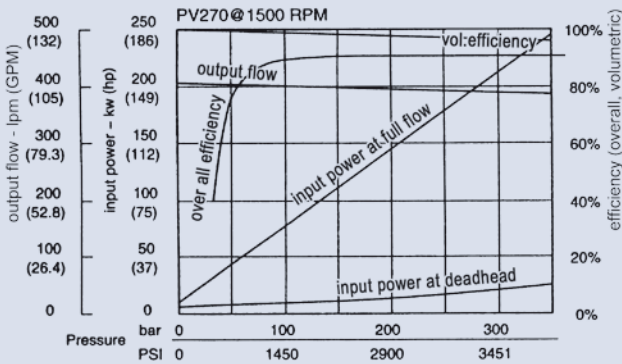
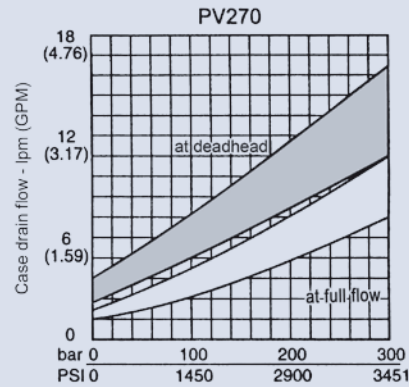
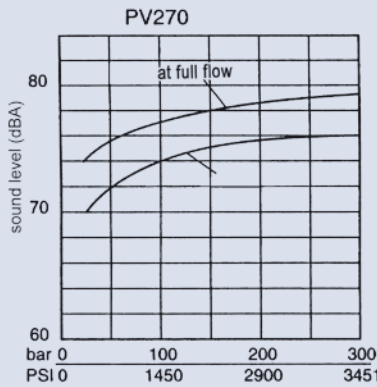

Pump Accessories

Bell housing, coupling and foot flange

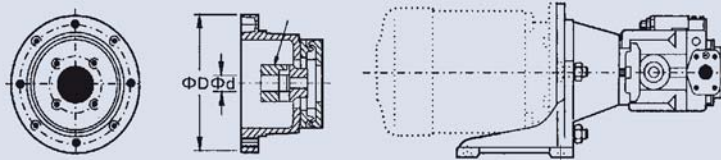

Welding flange, Threaded flange

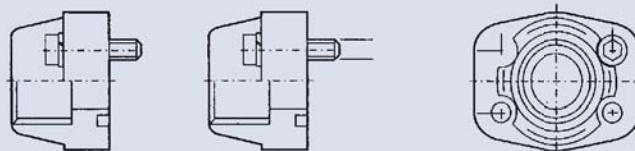

SAE-flange connections, pipe connection in accordance to DIN-2353

Elbow SAE-flange connection WFS

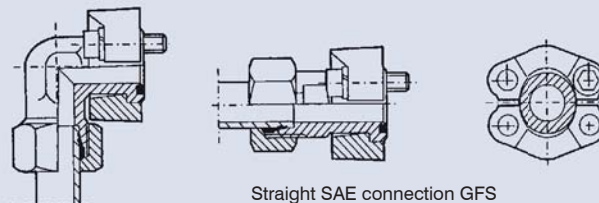

Straight SAE connection GFS

PV SERIES AXIAL PISTON PUMP

Dimensions

PV016~PV023

Mounting: M,N

mounting hole for horse power compensator pilot or displacement feedback LVDT

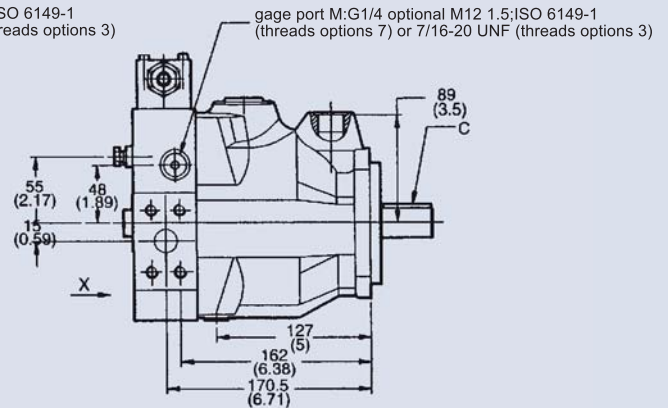
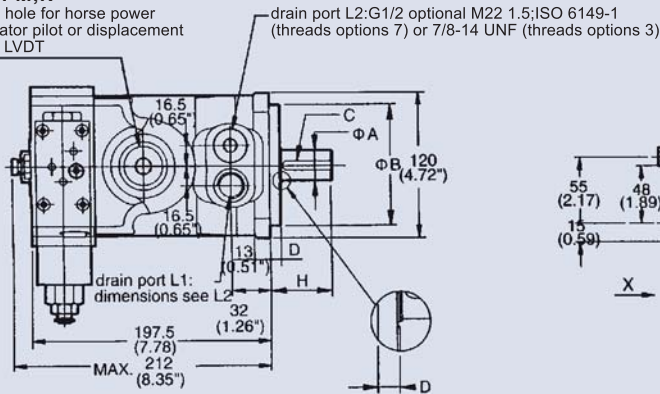

Mounting: K,D

mounting hole for horse power compensator pilot or displacement feedback LVDT

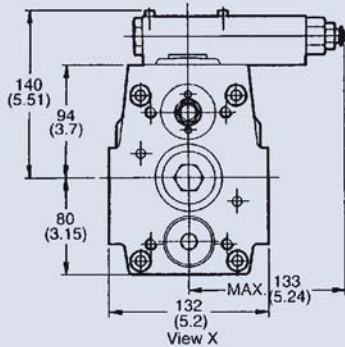
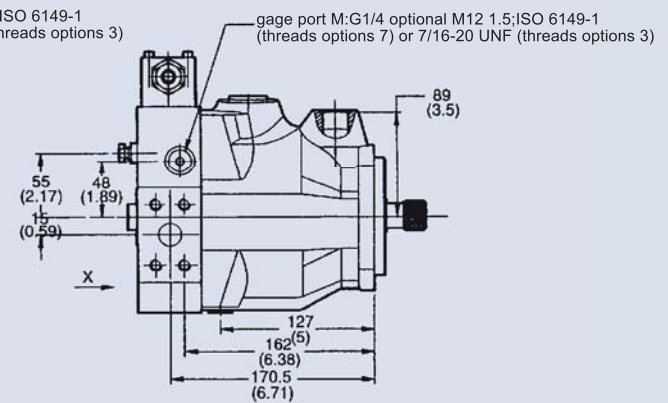
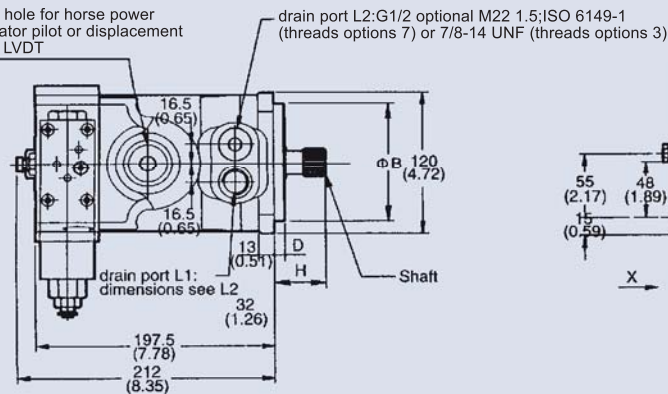

Shown with standard pressure compensator

Outlet: flange according ISO 6162 DN 19; PN 400 bar

4 M10, 18 deep optional 3/8-16 UNC-2B (threads options 3 and 7)

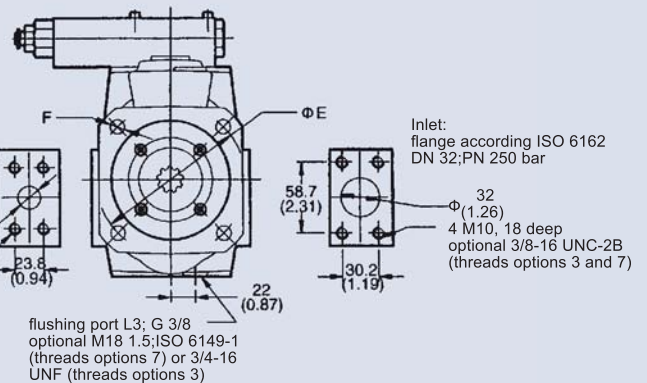

PV016~PV023 Dimensions

Mounting		ISO 3019/2	ΦA	ΦB	C	D	ΦE	F	H
M (standard)	Metric	Splined, DIN 5480	ø25	ø100 h8	8x7x40	9	125	12	52
	Inch	Cylindric, key	ø25.4 (1")	ø101.6 (4")	6.35x6.35x40 (1/4")	9.4 (0.37")	127 (5")	12 (0.47")	50 (1.97")
Mounting		ISO 3019/2	Shaft		ΦB	D	ΦE	F	H
K (standard)	Metric	Splined, DIN 5480	Splined W25x1.5x15x8f		ø100 h8	9	125	12	43
	Inch	Splined, SAE	Splined 15T 16/32 DP, flat root, side fit ANSI B92.1		ø101.6 (4")	9.4 (0.37")	127 (5")	12 (0.47")	46 (1.81")

PV SERIES AXIAL PISTON PUMP

Dimensions

PV032~PV046

Mounting: M,N

mounting hole for horse power compensator pilot or displacement feedback LVDT

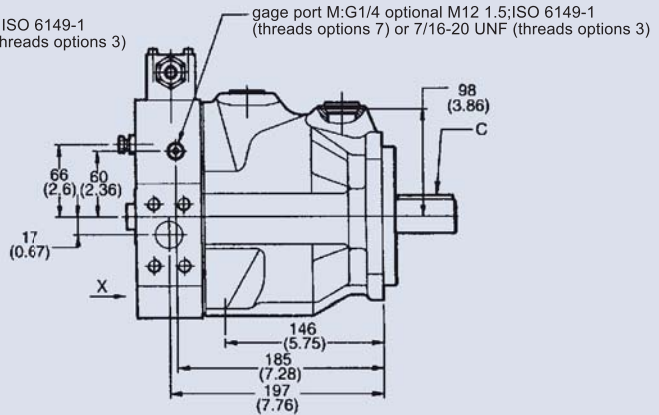
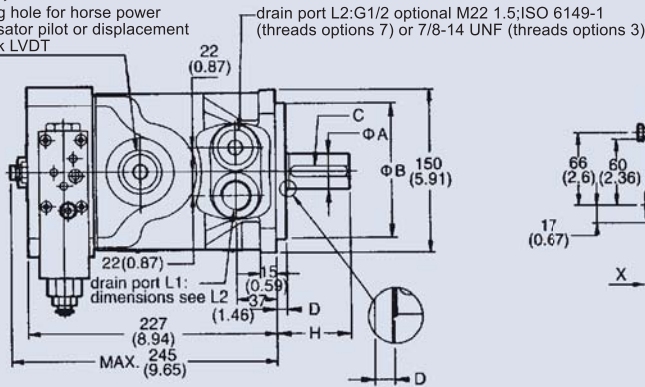

Mounting: K,D

mounting hole for horse power compensator pilot or displacement feedback LVDT

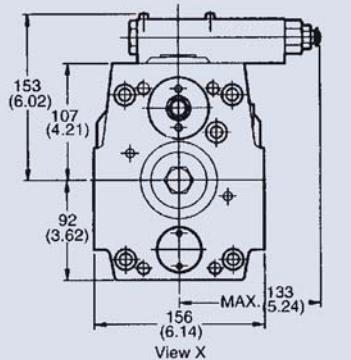
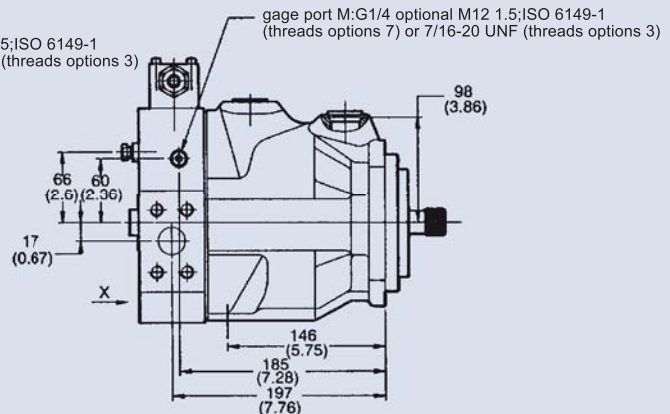
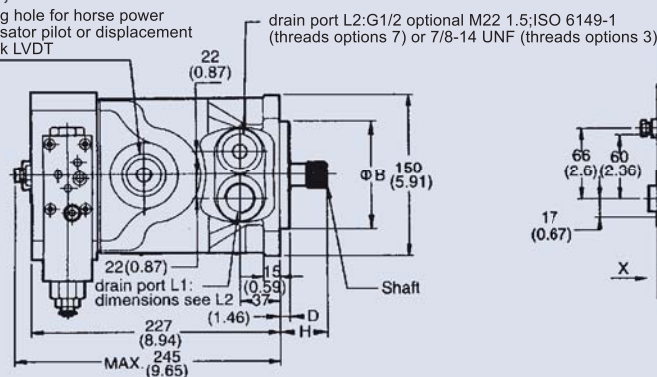

Outlet:
flange according ISO 6162
DN 19;PN 400 bar

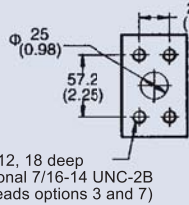

4 M12, 18 deep
optional 7/16-14 UNC-2B
(threads options 3 and 7)

Inlet:
flange according ISO 6162
DN 32;PN 250 bar

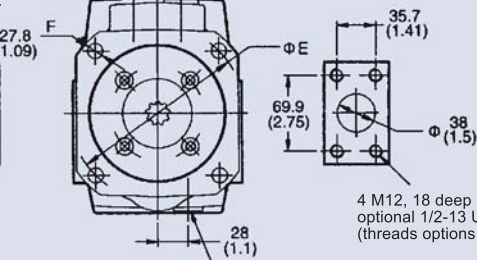

4 M12, 18 deep
optional 1/2-13 UNC-2B
(threads options 3 and 7)

flushing port L3; G 1/2
optional M22 1.5;ISO 6149-1
(threads options 7) or 7/8-14
UNF (threads options 3)

Shown with standard pressure compensator

PV032~PV046 Dimensions

Mounting			øA	øB	C	D	øE	F	H
M (standard)	Metric	ISO 3019/2 Splined, DIN 5480	ø32	ø125 h8	10x8x56	9	160	14	68
	Inch	ISO 3019/2 Cylindric, key	ø31.75 (1.25")	ø127 (5")	7.94x7.94x56 (5/16")	12.7 (0.5")	161.93 (6.38")	14 (0.55")	68 (2.68")
K (standard)	Mounting		Shaft		øB	D	øE	F	H
	Metric	ISO 3019/2 Cylindric, key	Splined W32x1.5x20x8f DIN 5480		ø125 h8	9	160	14	47
D	Inch	ISO 3019/1 Splined, SAE	Splined 14T 12/24 DP, flat root, side fit ANSI B92.1		ø127 (5")	12.7 (0.5")	161.93 (6.38")	14 (0.55")	56 (2.31")
D1	Inch	ISO 3019/1 Splined, SAE	Splined 15T 16/32 DP, flat root, side fit ANSI B92.1		ø127 (5")	12.7 (0.5")	161.93 (6.38")	14 (0.55")	56 (2.31")

PV SERIES AXIAL PISTON PUMP

Dimensions

PV063~PV092

Mounting: M,N

mounting hole for horse power compensator pilot or displacement feedback LVDT

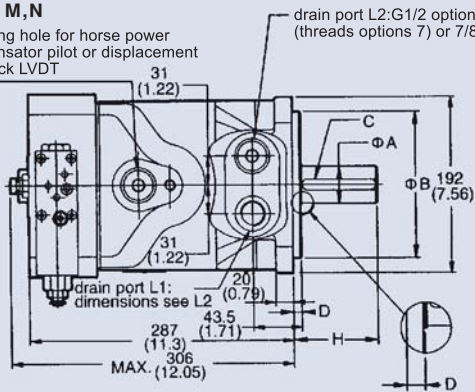

drain port L2: G1/2 optional M22 1.5; ISO 6149-1 (threads options 7) or 7/8-14 UNF (threads options 3)

gage port M: G1/4 optional M12 1.5; ISO 6149-1 (threads options 7) or 7/16-20 UNF (threads options 3)

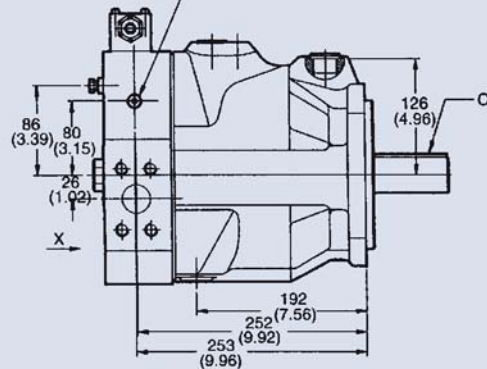

Mounting: K,D

mounting hole for horse power compensator pilot or displacement feedback LVDT

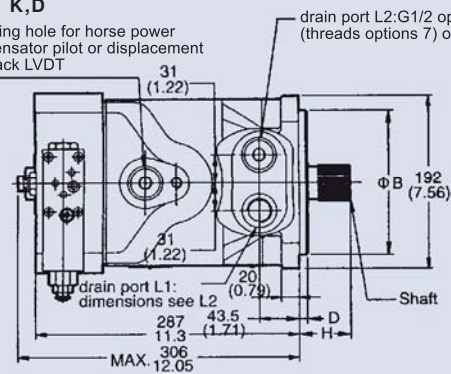

drain port L2: G1/2 optional M22 1.5; ISO 6149-1 (threads options 7) or 7/8-14 UNF (threads options 3)

gage port M: G1/4 optional M12 1.5; ISO 6149-1 (threads options 7) or 7/16-20 UNF (threads options 3)

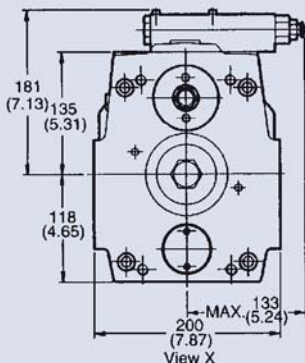
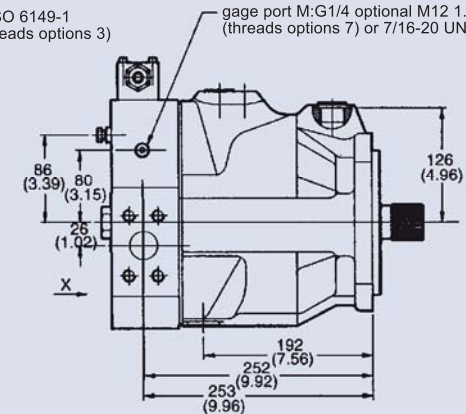

Shown with standard pressure compensator

Outlet: flange according ISO 6162 DN 19; PN 400 bar

4 M20, 20 deep optional 1/2-13 UNC-2B (threads options 3 and 7)

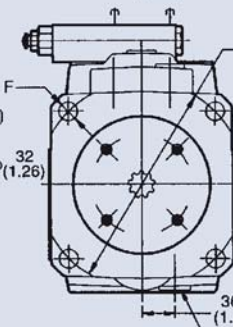

flushing port L3: G 1/2 optional M22 1.5; ISO 6149-1 (threads options 7) or 7/8-14 UNF (threads options 3)

Inlet: flange according ISO 6162 DN 32; PN 250 bar

4 M12, 20 deep optional 1/2-13 UNC-2B (threads options 3 and 7)

PV063~PV092 Dimensions									
Mounting			øA	øB	C	D	øE	F	H
M (standard)	Metric	ISO 3019/2 Splined, DIN 5480	ø40	ø160 h8	12x8x80	9	200	18	92
		ISO 3019/2 Cylindric, key	ø44.45 (1.75")	ø152.4 (6")	11.11x11.11x80 (7/16")	12.7 (0.5")	228.6 (9")	20.6 (0.81")	90 (3.54")
Mounting			Shaft		øB	D	øE	F	H
K (standard)	Metric	ISO 3019/2 Cylindric, key	Splined W40x1.5x25x8f DIN 5480		ø160 h8	9	200	18	56
		ISO 3019/1 Splined, SAE	Splined 15T 16/32 DP, flat root, side fit ANSI B92.1		ø152.4 (6")	12.7 (0.5")	228.6 (9")	20.6 (0.81")	75 (2.95")

PV SERIES AXIAL PISTON PUMP

Dimensions

PV140~PV180

Mounting: M,N

mounting hole for horse power compensator pilot or displacement feedback LVDT

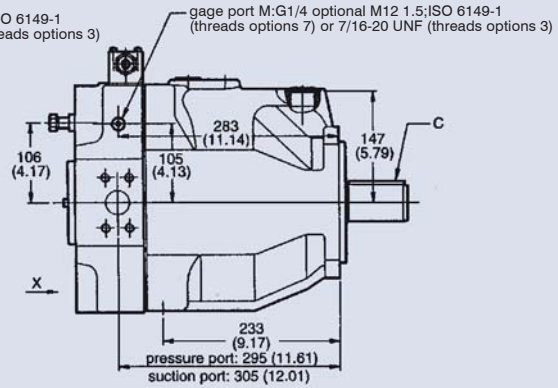
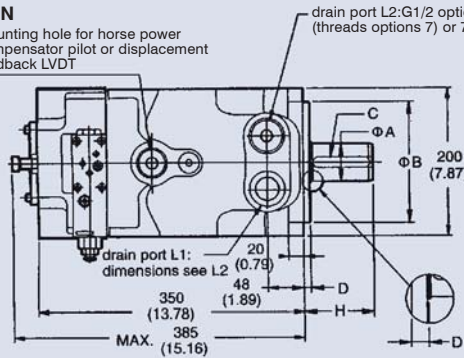

Mounting: K,D

mounting hole for horse power compensator pilot or displacement feedback LVDT

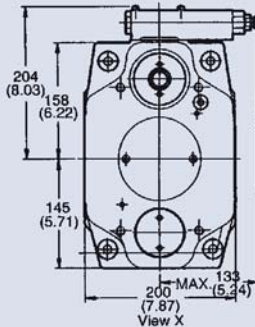
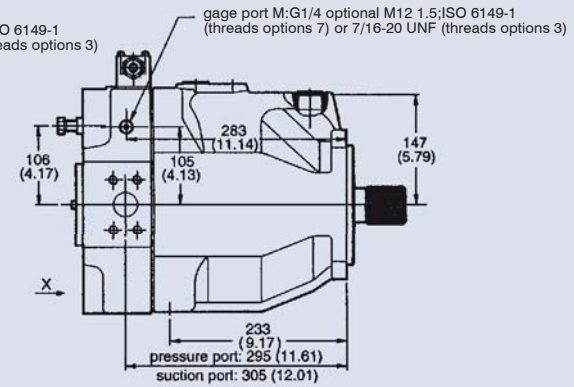
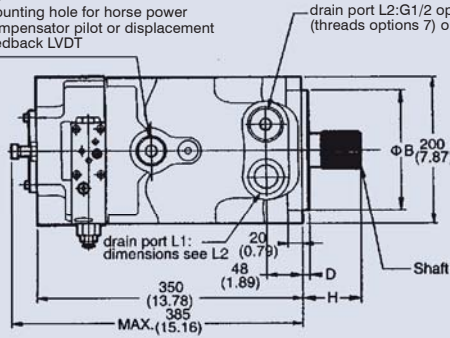

Shown with standard pressure compensator

Outlet: flange according ISO 6162 DN 19;PN 400 bar

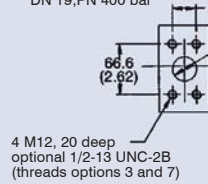

4 M12, 20 deep optional 1/2-13 UNC-2B (threads options 3 and 7)

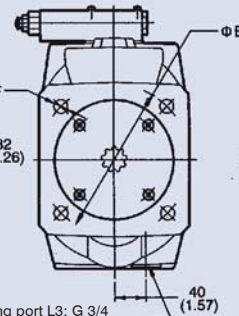

Inlet: flange according ISO 6162 DN 32;PN 250 bar

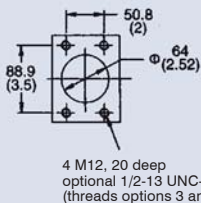

4 M12, 20 deep optional 1/2-13 UNC-2B (threads options 3 and 7)

flushing port L3; G 3/4 optional M27 2;ISO 6149-1 (threads options 7) or 1 1/16-12 UNF (threads options 3)

PV140~PV180 Dimensions

Mounting			øA	øB	C	D	øE	F	H
M (standard)	Metric	ISO 3019/2	ø50	ø160 h8	14x9x75	9	200	18	92
		Splined, DIN 5480							
N	Inch	ISO 3019/2	ø50.8 (2")	ø152.4 (6")	12.7x12.7x75 (1/2")	12.7 (0.5")	228.6 (9")	20.6 (0.81")	99.4 (3.91")
		Cylindric, key							
F	Inch	ISO 3019/2	ø44.45	ø152.4 (6")	11.11x11.11	12.7 (0.5")	228.6 (9")	20.6 (0.81")	75 (2.95")
		Splined, DIN 5480							
Mounting			Shaft		øB	D	øE	F	H
H (standard)	Metric	ISO 3019/2	Splined W50x2x24x8f		ø160 h8	9	200	18	78
		Cylindric, key	DIN 5480						
D	Inch	ISO 3019/1	Splined 15T 8/16 DP, flat root, side fit ANSI B92.1		ø152.4 (6")	12.7 (0.5")	228.6 (9")	20.6 (0.81")	88 (3.46")
		Splined, SAE							
G	Inch	ISO 3019/1	Splined 13T 8/16 DP, flat root, side fit ANSI B92.1		ø152.4 (6")	12.7 (0.5")	228.6 (9")	20.6 (0.81")	75 (2.95")
		Splined, SAE							

PV SERIES AXIAL PISTON PUMP

Dimensions

PV270

Mounting: M,N

mounting hole for horse power compensator pilot or displacement feedback LVDT

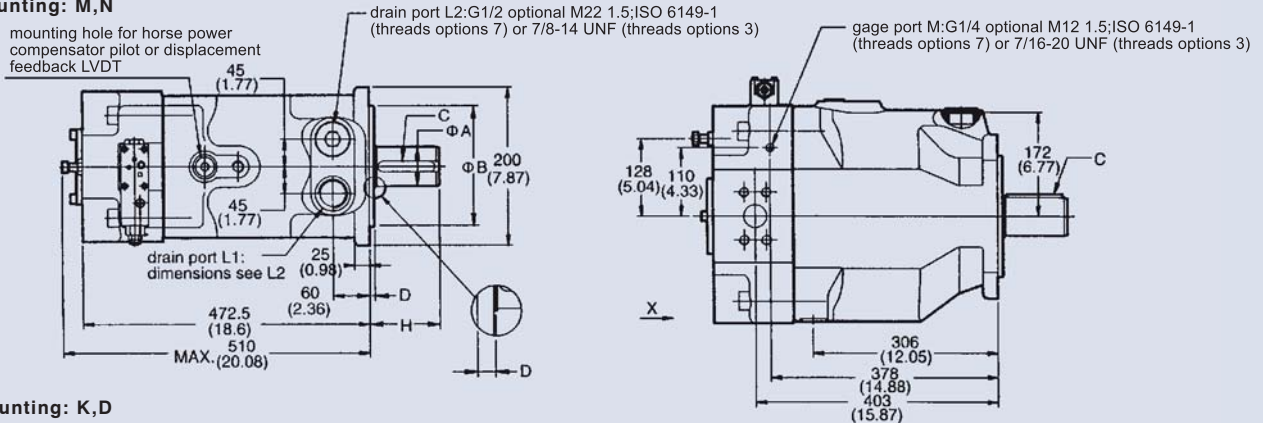

Mounting: K,D

mounting hole for horse power compensator pilot or displacement feedback LVDT

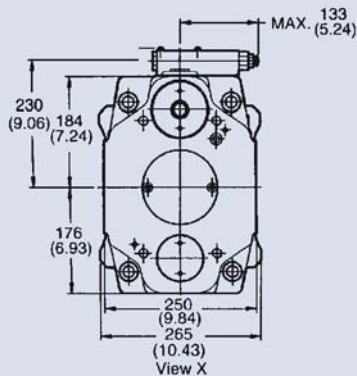
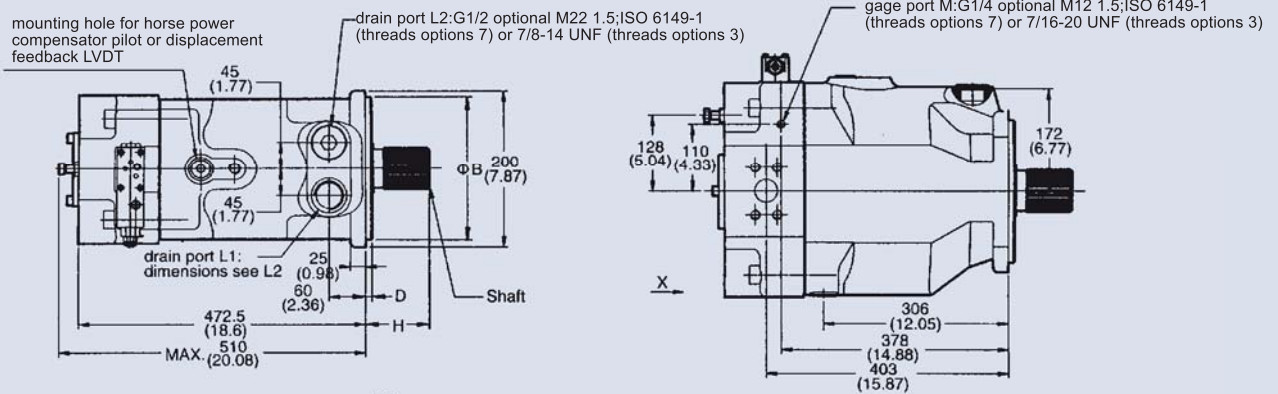

Shown with standard pressure compensator

Outlet: flange according ISO 6162 DN 19; PN 400 bar

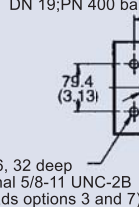

4 M16, 32 deep optional 5/8-11 UNC-2B (threads options 3 and 7)

Inlet: flange according ISO 6162 DN 32; PN 250 bar

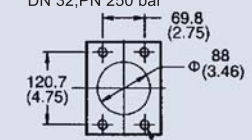

4 M16, 32 deep optional 5/8-11 UNC-2B (threads options 3 and 7)

flushing port L3: G 3/4 optional M27 2; ISO 6149-1 (threads options 7) or 1 1/16-12 UNF (threads options 3)

PV270 Dimensions									
	Mounting		øA	øB	C	D	øE	F	H
M (standard)	Metric	ISO 3019/2 Splined, DIN 5480	ø65	ø200 h8	18x11x98	9	250	22	115
N	Inch	ISO 3019/2 Cylindric, key	ø50.8 (2")	ø165.1 (6.5")	12.7x12.7x75 (1/2")	15.9 (0.37")	317.5 (12.5")	20.6 (0.81")	97.5 (3.84")
	Mounting		Shaft		øB	D	øE	F	H
K (standard)	Metric	ISO 3019/2 Cylindric, key	Splined W60x2x28x8f DIN 5480		ø200 h8	9	250	22	80
D	Inch	ISO 3019/1 Splined, SAE	Splined 15T 8/16 DP, flat root, side fit ANSI B92.1		ø165.1 (6.5")	15.9 (0.37")	317.5 (12.5")	20.6 (0.81")	88(3.46")

PV SERIES AXIAL PISTON PUMP

Thru drive, shaft load limitations

The max. transferable torque in Nm for the different shafts options are:

Shaft code	PV16~23	PV32~46	PV63~92	PV140~180	PV270
N	300	550	1320	2000	2000
D	300	610	1218	2680	2680
F	-	-	-	1320	-
G	-	-	-	1640	-
M	300	570	1150	1900	2850
K	405	675	1400	2650	3980

Important notice

The max. allowable torque of the individual shaft must not be exceeded. For 2-pump combinations there is no problem because PV series offers 100% thru torque. For 3-pump combinations (and more) the limit torque could be reached or exceeded.

Therefore it is necessary to calculate the torque factor and compare it with the allowed torque limit factor in the table.

**Required: calculated torque factor
<torque limit factor**

To make the necessary calculations easier and more user friendly it is not required to calculate actual torque requirements in Nm and compare them with the shaft limitations. The table on the right shows limit factors that include material specification, safety factors and conversion factors.

The total torque factor is represented by the sum of the individual torque factors of all pumps in the complete pump combination.

The torque factor of each individual pump is calculated by multiplying the max. operating pressure p of the pump (in bar) with the max. displacement Vg of the pump (in cc/rev)

Pump	Shaft	Torque limit factor
PV016 ~ PV023	N	17700
	D	17700
	M	17700
	K	20130
PV032 ~ PV046	N	32680
	D	36380
	M	33810
	K	40250
PV063 ~ PV092	N	77280
	D	72450
	M	67620
PV140 ~ PV180	K	83720
	N	118400
	D	158760
	F	78750
	G	97650
PV270	M	113400
	K	157500
	N	119000
	D	159700
	M	170100
	K	236250

**Total torque factor of the combination =
sum of individual torque factors of all pumps**

**Torque factor of any pump = P x Vg
(Pressure in bar x displacement in cc/rev)**

PV SERIES AXIAL PISTON PUMP

Decomposition Chart

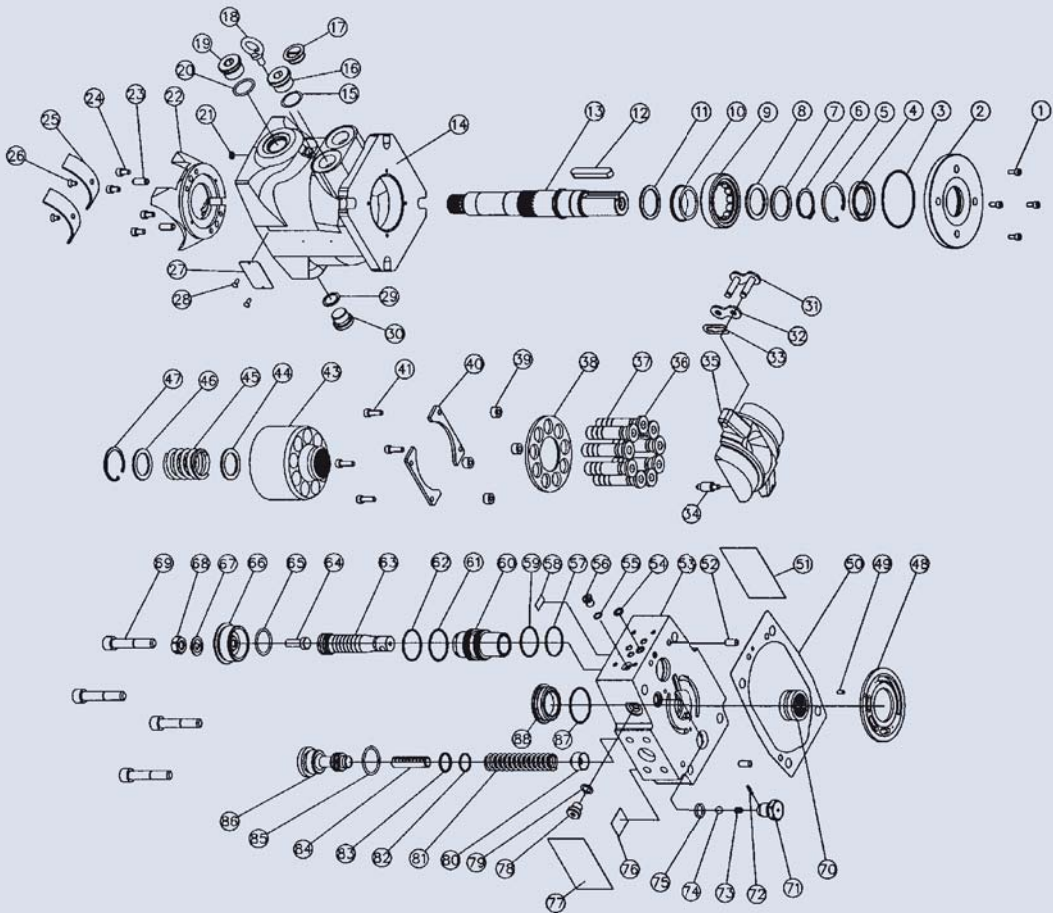

List of parts

No.	Description	Quantity	No.	Description	Quantity	No.	Description	Quantity	No.	Description	Quantity
1	Head cap screw	4	23	Pin	2	46	Washer	1	68	Piston nut	1
2	Pilot cover	1	24	Screw	4	47	Snap ring	1	69	Screw	1
3	O-ring	1	25	Trunnion bearing	2	48	Valve plate	1	70	Trunnion bearing	1
4	Shaft seal	1	26	Screw	2	49	Pin	1	71	Plug	1
5	Snap ring	1	27	Name plate	1	50	Seal	1	72	Pin	1
6	Snap ring	1	28	Rivet	2	51	Seal	1	73	Spring	1
7	Washer	1	29	O-ring	1	52	Pin	1	74	Ball	1
8	Washer	1	30	Plug	1	53	Pump body	2	75	O-ring	2
9	Roller bearing	1	31	Chain link	1	54	O-ring	1	76	Label	1
10	Roller bearing	1	32	Chain link	1	55	O-ring	1	77	Seal	1
11	Roller bearing	1	33	Chain link	1	56	Plug	1	78	Plug	1
12	Key	1	34	Connector servo spring	1	57	O-ring	1	79	O-ring	1
13	Shaft	1	35	Swash plate	1	58	Label	1	80	Washer	1
14	Pump body	1	36	Piston	9	59	O-ring	1	81	Spring	1
15	O-ring	1	37	Piston	9	60	Servo piston sleeve	1	82	O-ring	1
16	Plug	1	38	Slipper segment	1	61	O-ring	1	83	O-ring	1
17	Plug	1	39	Washer	4	62	O-ring	1	84	Pin	1
18	Ring	1	40	Retainer segment	2	63	Servo piston	1	85	O-ring	1
19	Plug	1	41	Screw	4	64	Set screw	1	86	Screw	1
20	O-ring	1	43	Cylinder block	1	65	O-ring	1	87	O-ring	1
21	O-ring	1	44	Washer	1	66	Servo spring cover	1	88	Spring cover	1
22	Cradle	1	45	Spring	1	67	Washer	1			

PV SERIES AXIAL PISTON PUMP

General installation information

1. Fluid recommendations

Premium quality hydraulic mineral oil fluids are recommended, like H-LP oils to DIN 51524, part 2. The viscosity range should be 25 to 50 s mm²/(cst) at 50°C. Operating temperatures -10 to +70°C. For other fluids such as phosphoric acid esters or for, other operating conditions consult HYDROME for assistance.

2. Seals

NBR (Nitrile) seals are used for operation with hydraulic fluids based on mineral oil. For synthetic, as perhaps phosphoric acid esters, Fluorocarbon seals are required. Consult HYDROME for assistance.

3. Filtration

For maximum pump and system component functionality and life, the system should be protected from contamination by effective filtration. Fluid cleanliness should be in accordance with ISO classification ISO 4406. The quality of filter elements should be in accordance with ISO standards.

- (1) Minimum requirement for filtration rate x (μm):
General hydraulic systems for satisfactory operation:
Class 19/15, to ISO 4406. $X=25 \mu\text{m}$ ($\beta_{10} \geq 75$) to ISO 4572
- (2) Hydraulic systems with maximized component life and functionality:
Class 16/13, to ISO 4406. $X=10 \mu\text{m}$ ($\beta_{10} \geq 75$) to ISO 4572
It is recommended to use return line or pressure filters. HYDROME Filter Division offers a wide range of these filters for all common applications and mounting styles. The use of suction filters should be avoided, especially with fast response pumps. Bypass filtration is a good choice for best filter efficiency.

4. Installation and mounting

Horizontal mounting: Outlet port side or top. Inlet port side or bottom, drain port always uppermost.

Vertical mounting: Shaft pointing upwards.

Install pump and suction line in such a way that the maximum inlet vacuum never exceeds 0.8 bar absolute.

The inlet line should be as short and as straight as possible. A short suction line cut to 45° is recommended when the pump is mounted inside the reservoir, to improve the inlet conditions. All connections to be leadfree, as air in the suction line will cause cavitations, noise, and damage to the pump.

5. Shaft rotation and alignment

Pump and motor shafts must be aligned within 0.25mm T.I.R. maximum. A floating coupling must be used.

Bell housings and couplings can be ordered at manufacturers listed in this catalogue. Please follow the coupling manufacturer's installation instructions.

Consult HYDROME for assistance on radial load type drives.

6. Start up

Prior to start up, the pump case must be filled with hydraulic fluid (use case drain port). Initial start up should be at zero pressure with an open circuit to enable the pump to prime. Pressure should only be increased once the pump has been fully primed.

Attention: Check motor rotation direction.

Operating noise of pumps

The normal operating noise of a pump and consequently the operating noise of the entire hydraulic system is largely determined by where and how the pump is mounted and how it is connected to the down stream hydraulic system. Also size, style and installation of the hydraulic tubing have a major influence on the overall noise emitted by a hydraulic system.

Noise reduction measures

Flexible elements help to prevent pump body vibration being transmitted to other construction elements, where possible amplification may occur, Such elements can be:

Bell housing with elastic dampening flange with vulcanized labyrinth ①

(1) Floating and flexible coupling ②

(2) Damping rails ③

(3) Or silent blocks for mounting the electric motor or the foot mounting flange

(4) Flexible tube connections (compensators) or hoses on inlet, outlet and drain port of the pump.

(5) Exclusive use of gas tight tube fittings for inlet connections to avoid ingress of air causing cavitations and excessive noise.

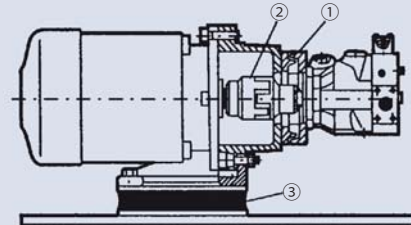

7. Drain line

The drain line must lead directly to the reservoir without restriction. The drain line must not be connected to any other return line. The end of the drain line must be below the lowest fluid level in the reservoir and as far away as possible from the pump inlet line. This ensures that the pump does not empty itself when not in operation and that hot aireated oil will not be recirculated. For the same reason, when the pump is mounted inside the reservoir, the drain line should be arranged in such a way that a siphon is created. This ensures that the according to the port size and a straight low pressure fitting with maximized bore should be used.

	PV016~PV023	PV032~PV046	PV063~PV092	PV140~PV180	PV270
Size of pipe joints	3/8 (ø8.5 or more)	1/2 (ø12 or more)	3/4 (ø16 or more)	1 (ø19 or more)	1-1/4 (ø22 or more)
I.D. of pipes	ø12 or more	ø15 or more	ø19 or more	ø25 or more	ø32 or more
Length of drain	Under 1m	Under 1m	Under 1m	Under 1m	Under 1m

PV SERIES TANDEM AXIAL PISTON PUMP

Dimensions

Pump Combination PV

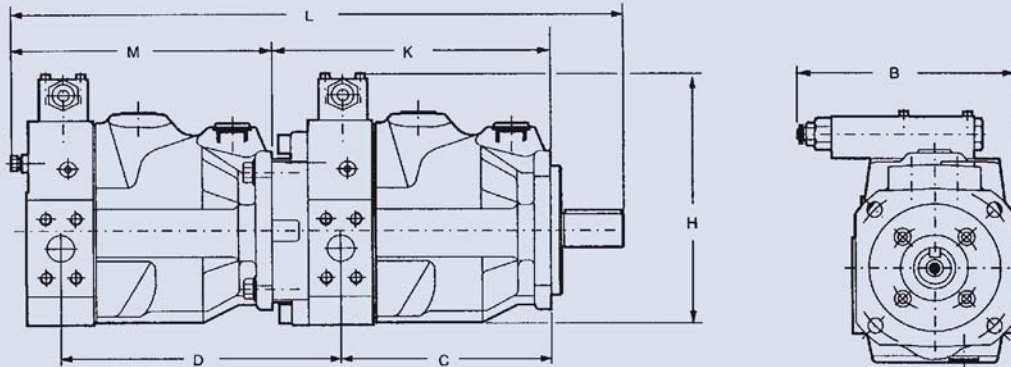

Main pump	Second pump	Interface main pump	L	B	C	D	H	K	M
PV16, 20, 23	PV16, 20, 23	100 B4 HW	489	196	170.5	225	220	225	212
PV32, 40, 46	PV16, 20, 23	125 B4 HW	541	208	197	235.5	245	261	212
	PV32, 40, 46		574		197	261	245	261	245
PV63, 80, 92	PV16, 20, 23	160 B4 HW	630	232	252	244.5	299	326	212
	PV32, 40, 46		663		252	271	299	326	245
	PV63, 80, 92		724		252	326	299	326	306
PV140, 180	PV16, 20, 23	160 B4 HW	719	230	305	280.5	349	415	212
	PV32, 40, 46		752		305	307	349	415	245
	PV63, 80, 92		813		305	362	349	415	306
	PV140, 180		878		305	415	349	415	385
PV270	PV16, 20, 23	200 B4 HW	860	255	403	299	406	531.5	212
	PV32, 40, 46		893		403	325.5	406	531.5	245
	PV63, 80, 92		954		403	380.5	406	531.5	306
	PV140, 180		1033		403	433.5	406	531.5	385
	PV270		1134		403	531.5	406	531.5	510

Combination PV140/180+PV140/180 and PV270+PV270 only with splined shaft on main pump due to high torque

PV pump with thru drive

List of parts

No.	Description
1	Connector
2	Coupling
3	Seal
4	Seal
5	Coupling

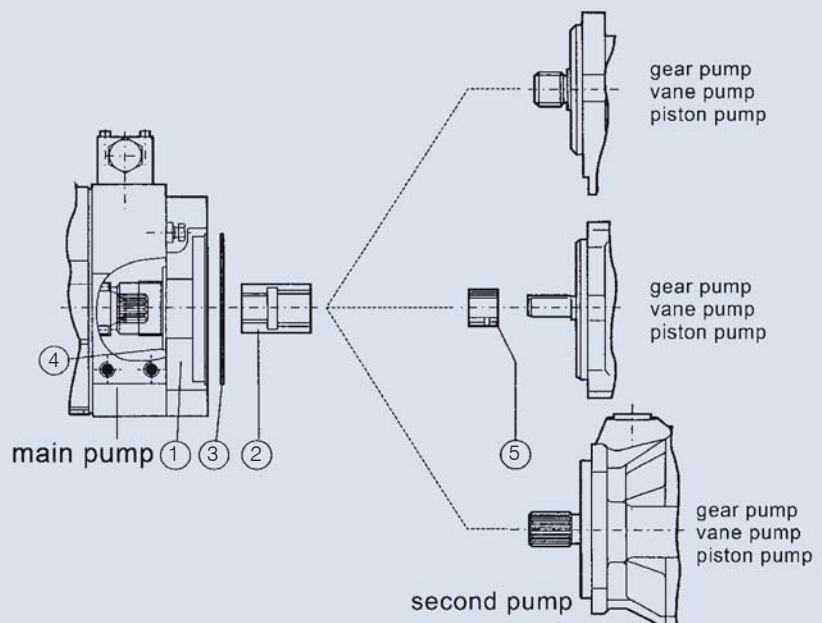

PVS, PZS SERIES VARIABLE VOLUME PISTON PUMP

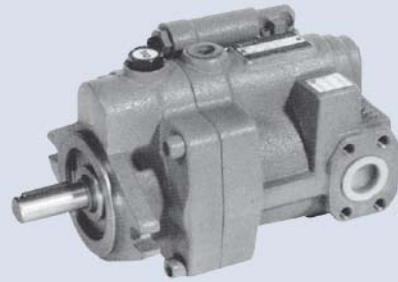
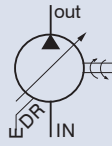

How to order

PVS - 1 B - 16 N 2 - R - ✖

1	2	3	4	5	6	7	8
1	PVS: Pump size 0, 1, 2 PZS: Pump size 3, 4						
2	Pump sizes: 0: 8 cc/rev 1: 16, 22 cc/rev 2: 36, 46 cc/rev 3: 70 cc/rev 4: 100 cc/rev						
3	Mounting Type: B: Flange type (normal) A: Foot type						
4	Displacement: 8, 16.5, 22, 36, 46, 70, 100 cc/rev						
5	Control types standard type: N Option type: P, NQ, RS (RA), WS (WA), HL						
6	Pressure adjusting PVS 0: 20-40 bar 1: 20-73 bar 2: 30-145 bar 3: 30-215 bar PZS 1: 20-73 bar 3: 30-215 bar 4: 30-286 bar						
7	Shaft rotation (viewed from shaft end) R: Clockwise L: Counter clockwise						
8	Shaft type none: Cylindric, key S: Splined, SAE						

Specifications

Model	Displacement cc/rev	Unloading Conditions (lpm)			Pressure Adj. Range bar	Max. Pressure bar	Input Speed Range (rpm)		Weight (kg)
		1200 rpm	1500 rpm	1800 rpm			Min.	Max.	
PVS-0B-8	8	9.6	12	14.4	0: 20-40	255	500	2000	9
PVS-1B-16	16.5	19.8	24.7	29.7	1: 20-73				12
PVS-1B-22	22	26.4	33	39.6	2: 30-145				23
PVS-2B-35	36	43.2	54	64.8	3: 30-215				23
PVS-2B-45	46	55.2	69	82.8		286	1800		41
PZS-3B-70	70	84	105	126	1: 20-73			41	
PZS-3B-70	70	84	105	126	3: 30-215			41	
PZS-4B-100	100	120	150	180	4: 30-286				60

Dimensions

PVS-0B-8N

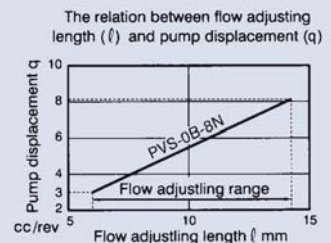
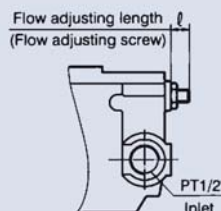
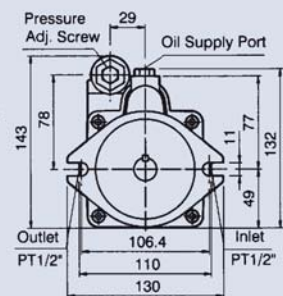
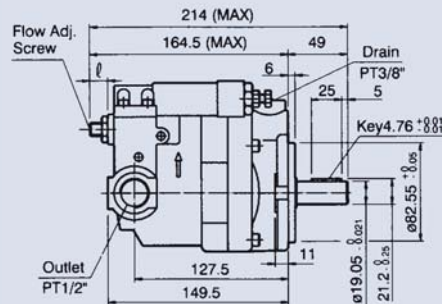
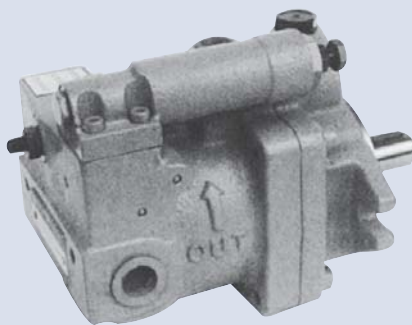

PVS, PZS SERIES VARIABLE VOLUME PISTON PUMP

Control Types

Type	External View	JIS Symbols	Characteristics	Description
N				Pressure Compensating Type (Manual) <ol style="list-style-type: none"> When the pressure reaches the value set with the compensator, the flow is reduced automatically and the set pressure is maintained. The pressure and flow are controlled manually.
P				Remote Pressure Control Type <ol style="list-style-type: none"> The pressure can be controlled according to the pilot pressure. The flow can be controlled manually.
NQ				Two Pressure-Two Flow Control Type <ol style="list-style-type: none"> By means of the sequence valve, two stage flow rate can be obtained and each flow rate has the different pressure eventually enabling energy savings.
RS (RA)				Solenoid Cut-Off Control Type <ol style="list-style-type: none"> An unloading solenoid valve is used to minimize the lost energy when the pump output is not required. Heat generated is very small.
WS (WA)				Two Pressure Cut-Off Control Type <ol style="list-style-type: none"> By means of "ON" "OFF" control of solenoid valves, two different pressure compensating types can be obtained.
HL				Load Sensing Control <ol style="list-style-type: none"> The "HL" compensator is used for load sensing circuits and is a true load sensor. This is the "P" compensator with a pin in the compensator spool. The pin prevents pilot flow from entering the circuit which will eliminate creeping of the load. The "HL" compensator will let the pump deliver a constant flow rate to the circuit by providing an adjustable ΔP across the customers orifice or valve. The pump will operate at 17.2~27.5 bar (250-400 psi) above "Load pressure".

Dimensions

PVS-1B-16N, PVS-1B-22N

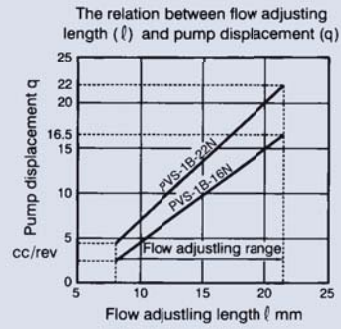
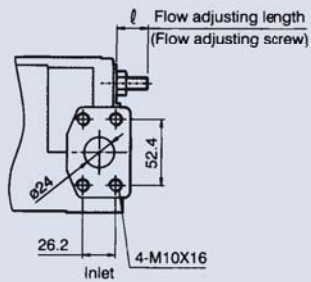
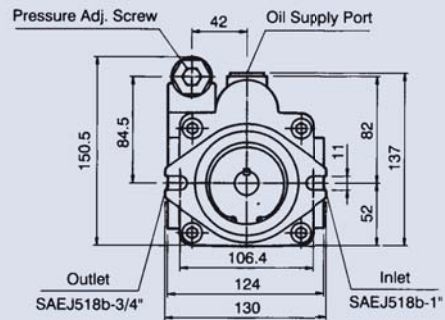
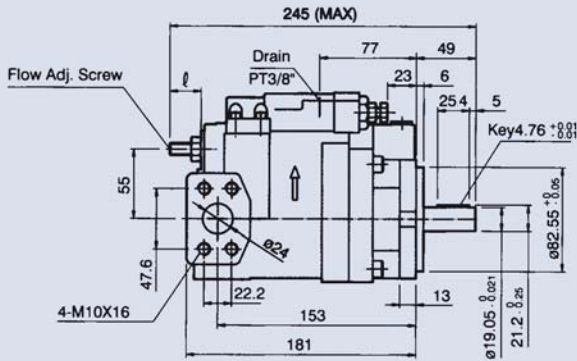

PVS-2B-35N, PVS-2B-45N

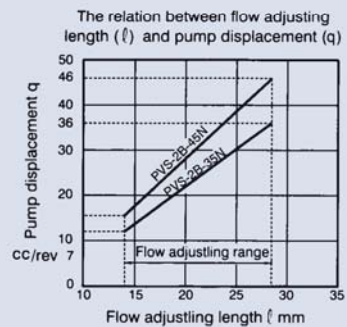
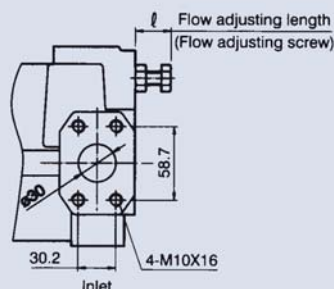
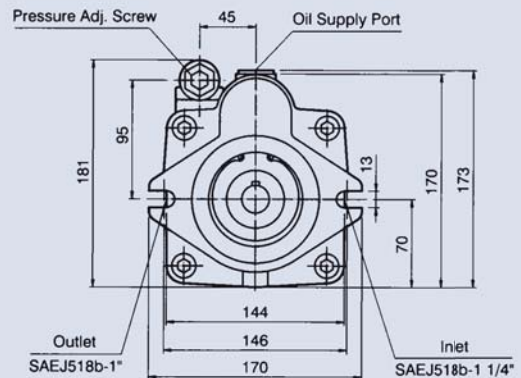
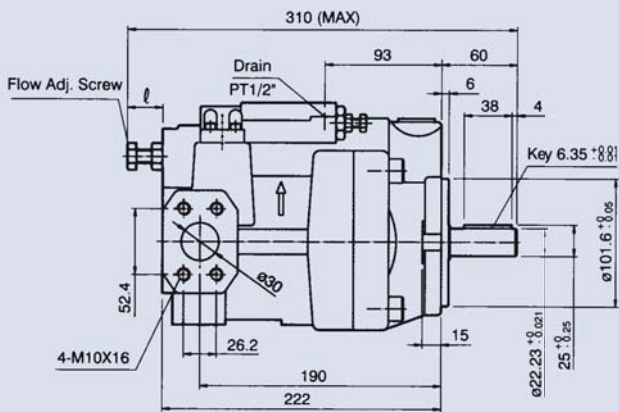

PVS, PZS SERIES VARIABLE VOLUME PISTON PUMP

Dimensions

PZS-3B-70N

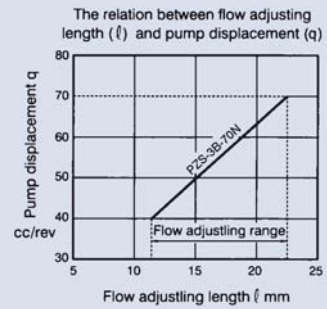
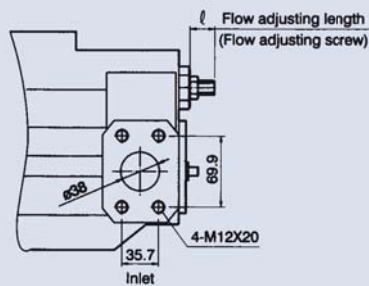
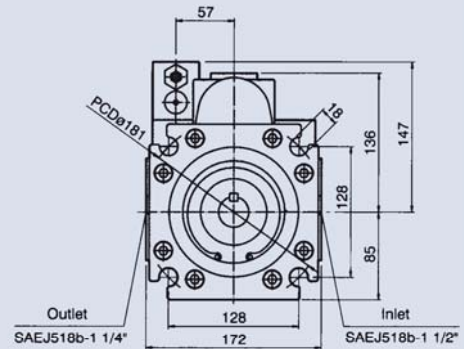
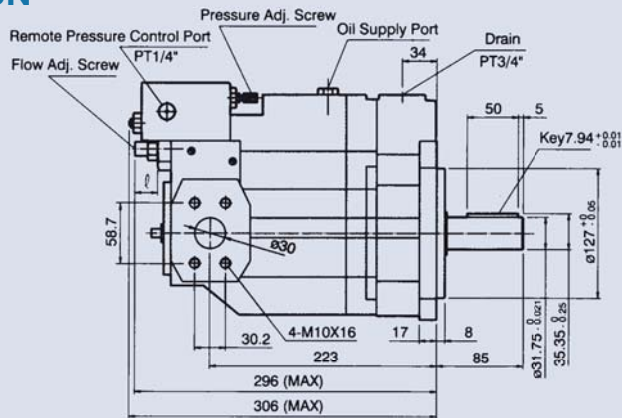

PZS-4B-100N

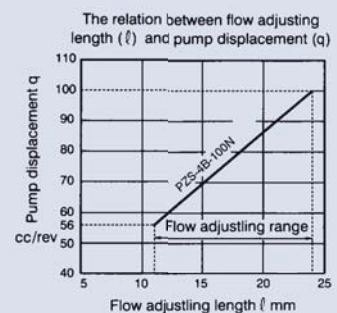
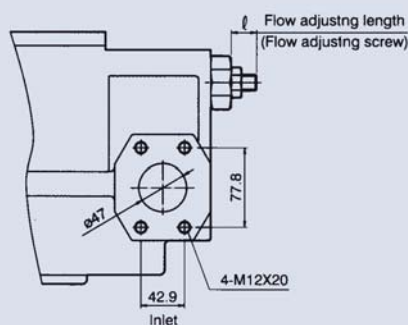
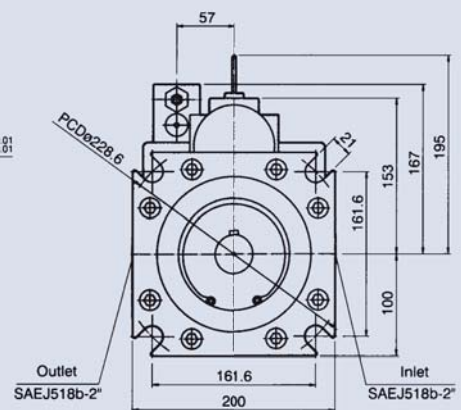
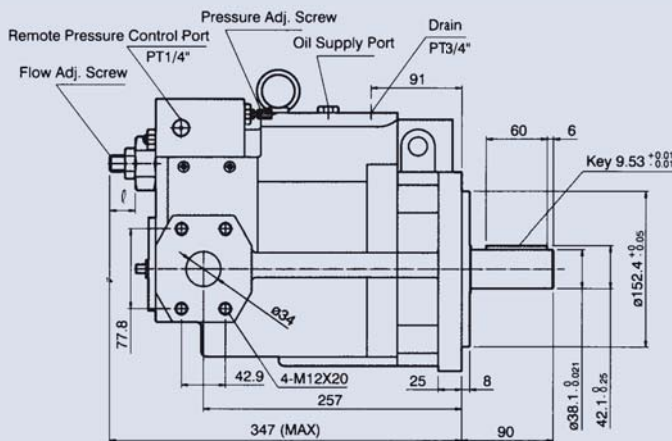

PVS, PZS SERIES VARIABLE VOLUME PISTON PUMP

Cross section drawing

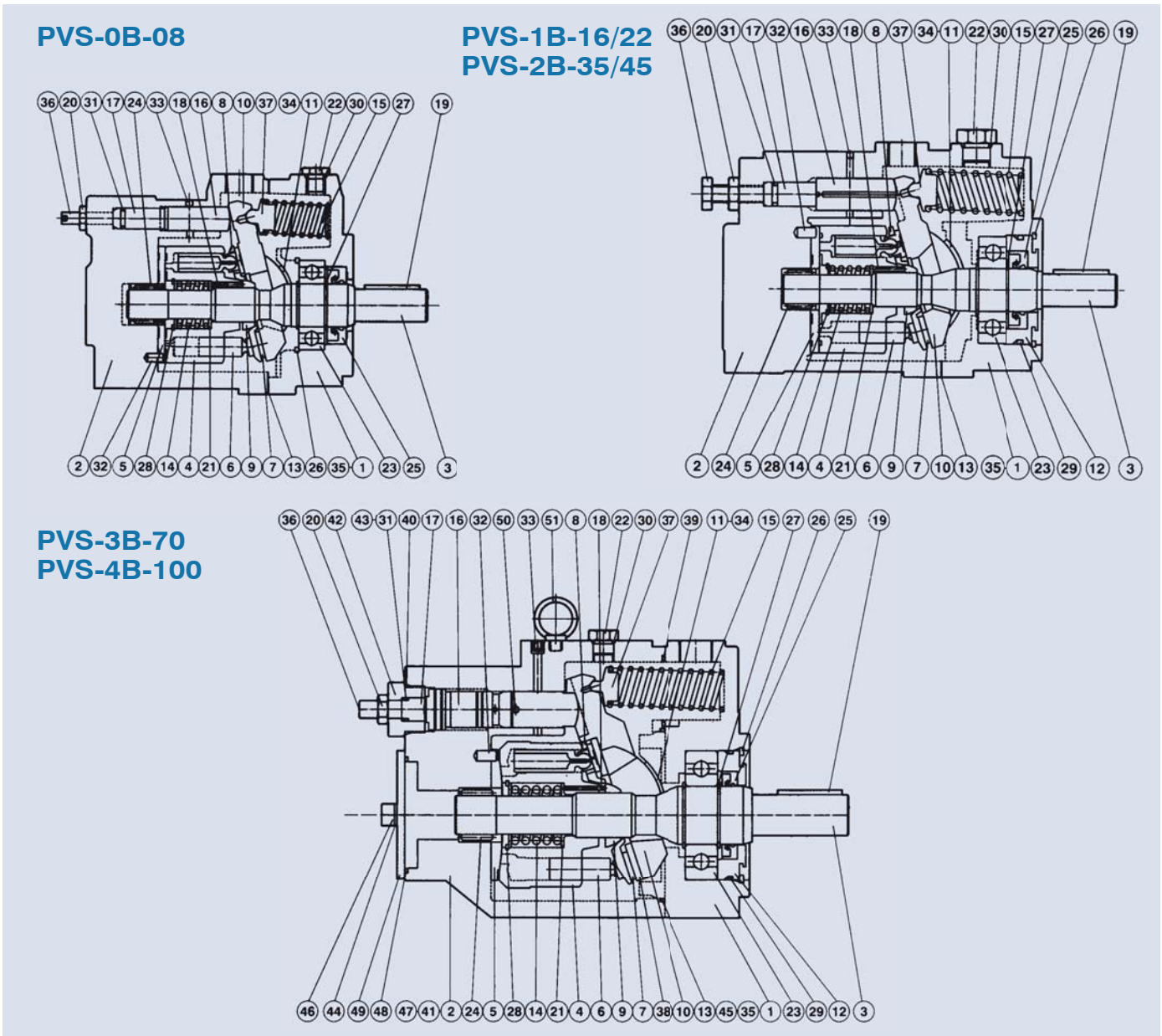

Parts list

N0.	Part Name	N0.	Part Name	N0.	Part Name	N0.	Part Name	N0.	Part Name
1	Body	9	Barrel holder	17	Guide	25	Oil seal	33	Expander plug
2	Case	10	Swash plate	18	Needle	26	Snap ring	34	Machine screw
3	Shaft	11	Thrust bush	19	Key	27	Snap ring	35	Machine screw
4	Cylinder barrel	12	Seal holder	20	Nut	28	Snap ring	36	Flow adj. screw
5	Valve plate	13	Gasket	21	Retainer	29	O-ring	37	Spring Holder
6	Piston	14	Spring	22	Plug	30	O-ring		
7	Shoe	15	Spring	23	Ball bearing	31	O-ring		
8	Shoe holder	16	Control Piston	24	Needle bearing	32	Pin		

FIXED DISPLACEMENT VANE PUMP

FEATURES:

1. Designed with high capacity in all aspects.
2. Special design consideration has been given to the flow passage to prevent anti-cavitation. Extreme smooth and quiet in operation, particularly suitable for in-plant application.
3. Maximum working pressure 1000 psi (70 bar), ideal to use as low pressure pump in Hi-Lo system because of price and performance.
4. Viewing from the shaft end, the direction of rotation is clockwise. (R)

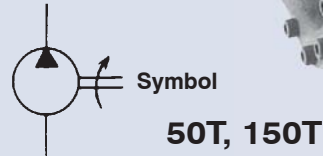

How to order

50T, 150T - 23 - L - R - L - ✖

- | | |
|---|---|
| 1 | Low pressure single vane pump |
| 2 | Displacement cc/rev |
| 3 | Mounting type F: Flange type L: Foot type (normal) |
| 4 | Shaft rotation (viewed from shaft end) R: Clockwise L: Counter-clockwise |
| 5 | Discharge port position (viewed from shaft end) L: Left side (normal) R: Right side |
| 6 | Shaft diameter for 50T None: ø22 (standard) 01: ø19.05 |

Specifications

Model	Displacement cc/rev	Delivery At No-Load Pressure (lpm)				Running Speed (rpm)		Max. Pressure (bar)	Weight (kg)	
		Running Speed (rpm)				Max.	Min.		Flange Type	Foot Type
		1000	1200	1500	1800					
50T	07	–	9.0	11.2	13.5	1800	1200	105	9.5	10.5
	12	12.0	14.4	18.0	21.6	1800	950	105		
	14	14.6	17.5	21.7	26.1	1800	950	105		
	17	17.0	20.3	25.5	31.5	1800	950	105		
	19	19.2	23.0	28.8	34.6	1800	950	105		
	21	21.1	25.3	31.7	38.0	1800	950	105		
	23	23.0	27.6	34.5	41.4	1800	950	105		
	26	26.2	31.4	39.3	47.2	1800	950	105		
	30	30.1	36.1	45.2	54.0	1800	950	105		
	36	36.2	43.4	54.3	–	1500	950	70		
	40	41.5	49.8	–	–	1200	950	70		
150T	48	48.3	57.9	72.4	86.9	1800	900	90	24	25
	61	61.5	73.8	92.2	110.7	1800	900	90		
	75	75.2	90.6	113.2	135.9	1500	900	90		
	94	94.2	113.0	141.3	–	1500	900	70		
	116	116.3	139.6	–	–	1200	900	70		

FIXED DISPLACEMENT VANE PUMP

Dimensions

50T FOOT TYPE

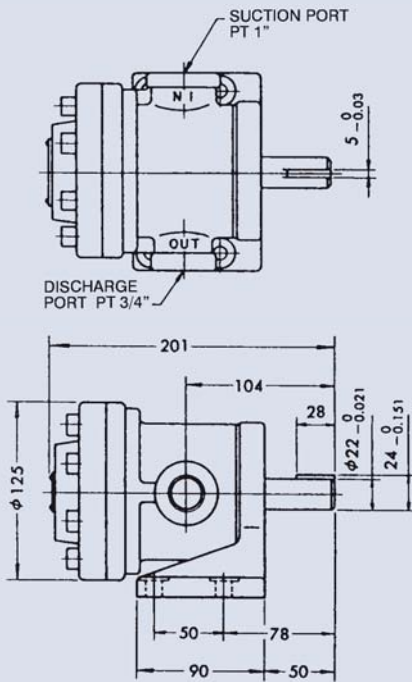

FLANGE TYPE

Unit:mm

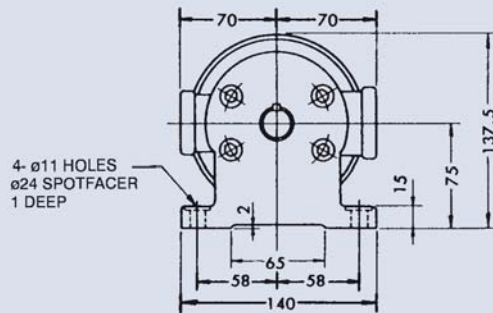
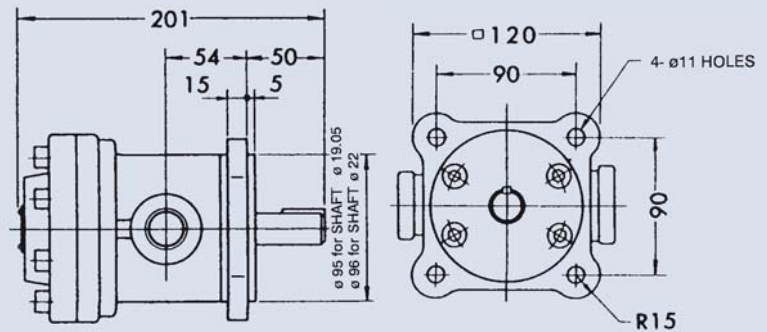

150T FOOT TYPE

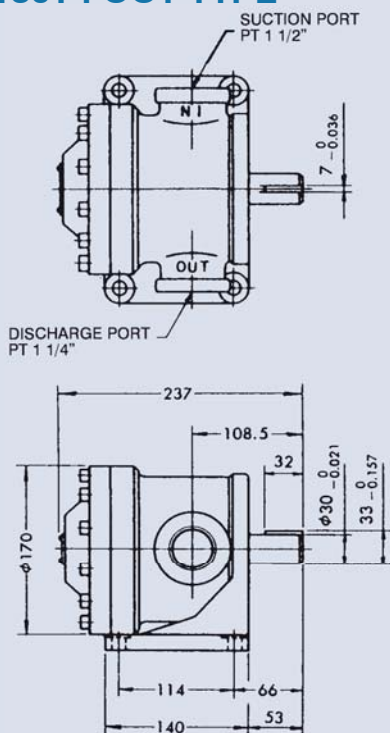

FLANGE TYPE

Unit:mm

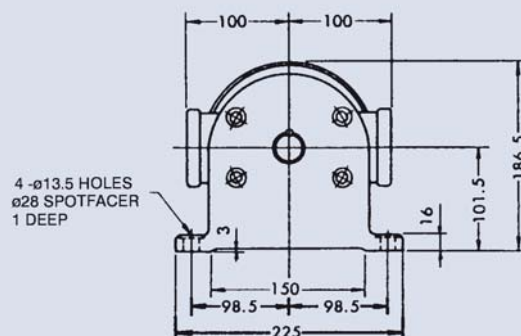
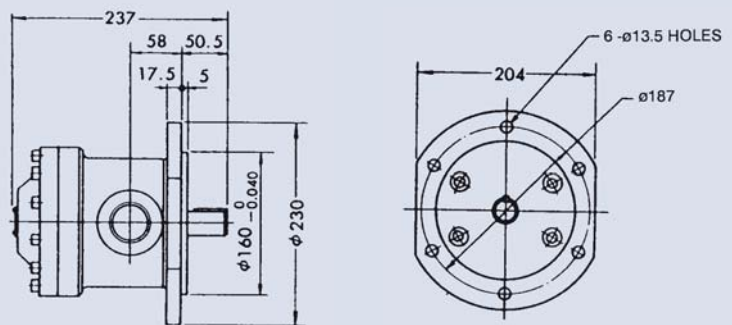

FIXED DISPLACEMENT VANE PUMP

50T, 150T Decomposition Chart

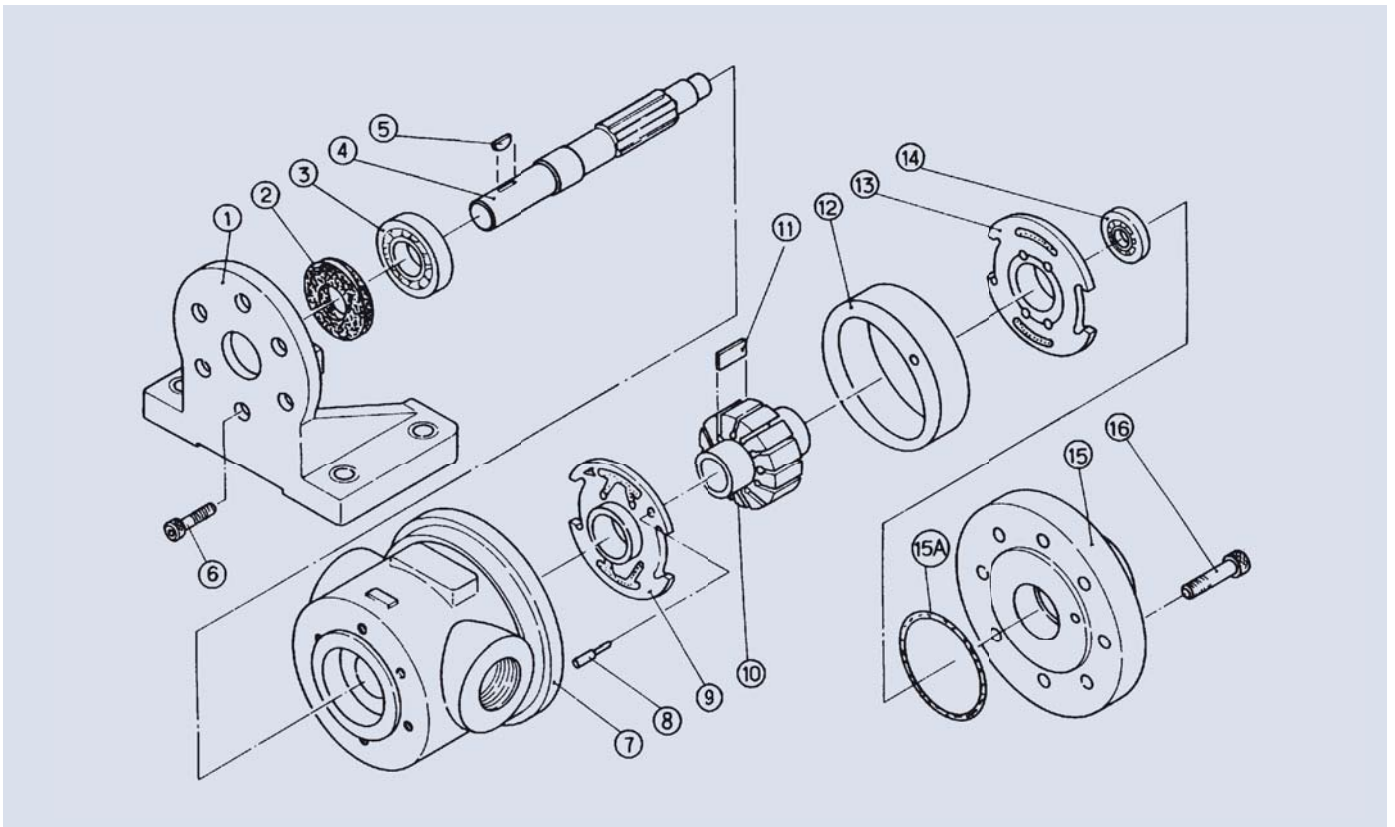

50T parts list

Item No.	Description	Specification	Q'ty
1	Foot (or) Flange		1
2	Seal	22x47x8	1
3	Bearing	6204ZZ	1
4	Shaft		1
5	Woodruff-Key	NO.607	1
6	Socket Head Cap Screws	M10x1.5x20	6
7	Body		1
8	Lock-Pin		1
9	"A" Port Plate		1
10	Rotor		1
11	Vanes		12
12	Cam Ring		1
13	"B" Port Plate		1
14	Bearing	6200	1
15	Cover		1
15A	O-Ring	G75	1
16	Socket Head Cap Screws	M10x1.5x30	8

150T parts list

Item No.	Description	Specification	Q'ty
1	Foot (or) Flange		1
2	Seal	32x52x9	1
3	Bearing	6205ZZ	1
4	Shaft		1
5	Key	7x7x35	1
6	Socket Head Cap Screws	M10x1.5x20	6
7	Body		1
8	Lock-Pin		1
9	"A" Port Plate		1
10	Rotor		1
11	Vanes		12
12	Cam Ring		1
13	"B" Port Plate		1
14	Bearing	6203	1
15	Cover		1
15A	O-Ring	G120	1
16	Socket Head Cap Screws	M10x1.5x40	8

FIXED DISPLACEMENT VANE PUMP

Performance curves



50T-12

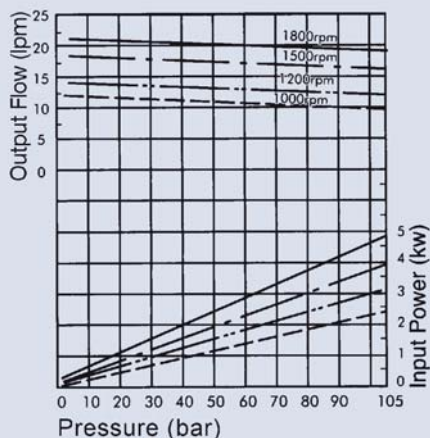

50T-14

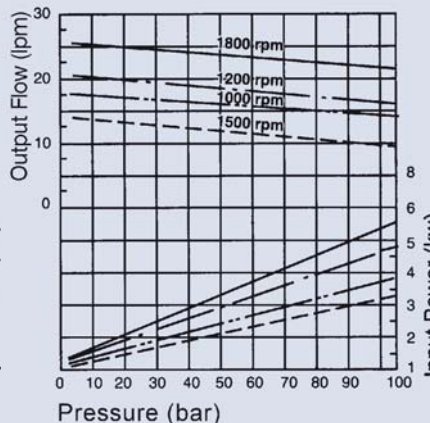

50T-17

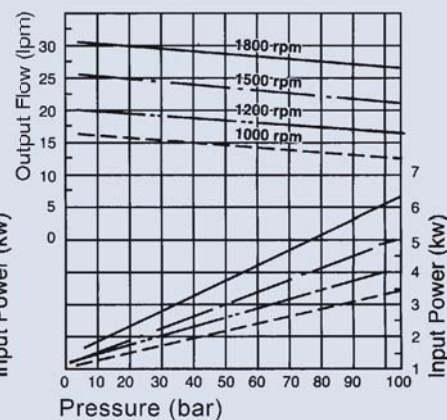

50T-21

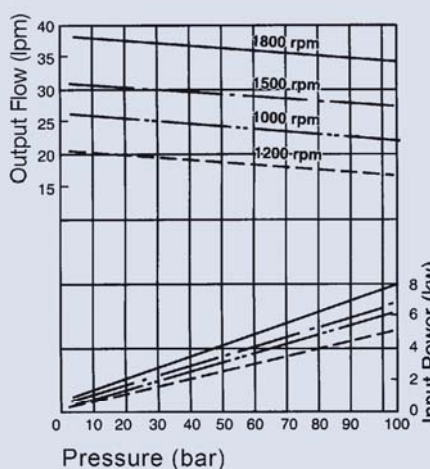

50T-23

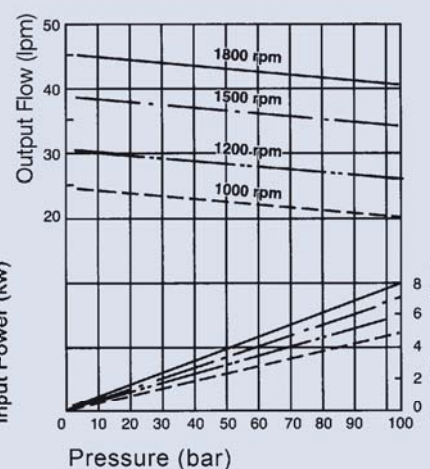

50T-30

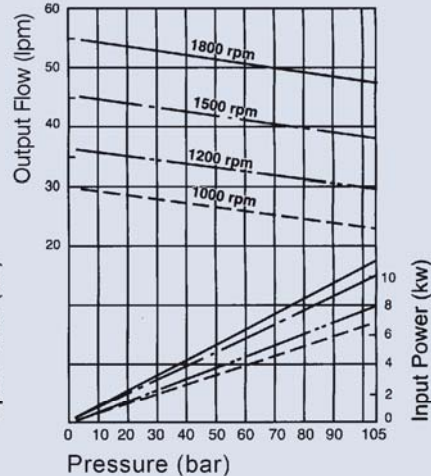

50T-36

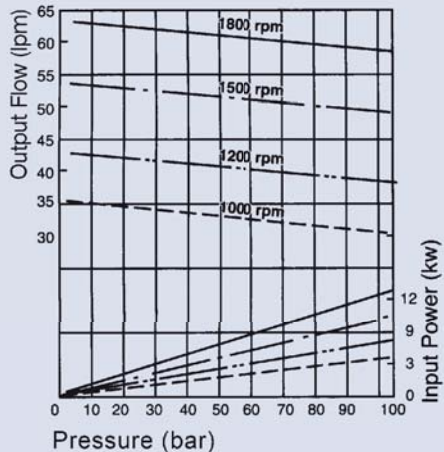

50T-40

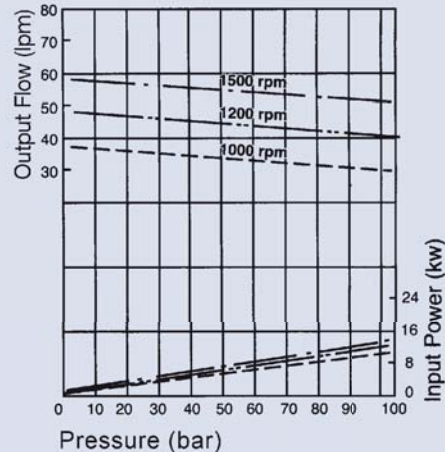

LOW PRESSURE VANE PUMP + HI-PRESSURE GEAR PUMP

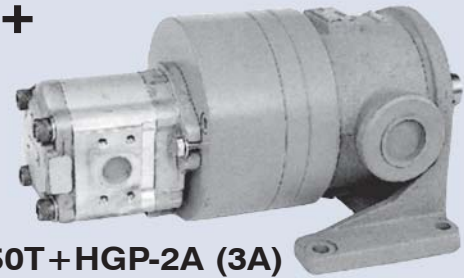
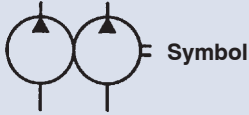

50T+HGP-2A (3A)
150T+HGP-2A (3A)

How to order

50T, 150T - 36 - 3 - ✖ - R - 01

1 2 3 4 5 6

1	Model
2	Vane pump displacement 36: 36cc/rev (see page. 81)
3	Gear pump displacement 3: 3cc/rev (see page. 129 HGP-2A, page. 131 HGP-3A)
4	Mounting type F: Flange type L: Foot type (normal)
5	Shaft rotation (viewed from shaft end) R: Clockwise L: Counter-clockwise
6	Shaft diameter for 50T None: $\varnothing 22$ (normal) 01: $\varnothing 19.05$

Dimensions

50T+HGP-2A

Unit:mm

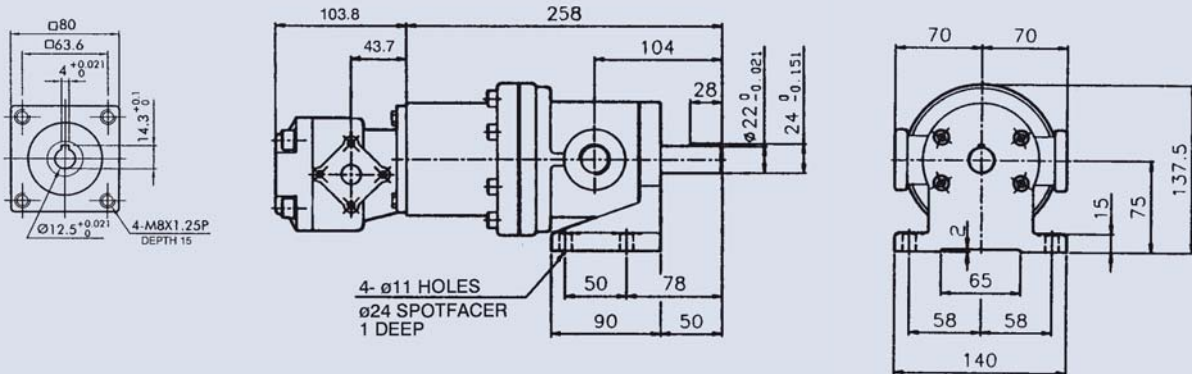

150T+HGP-2A

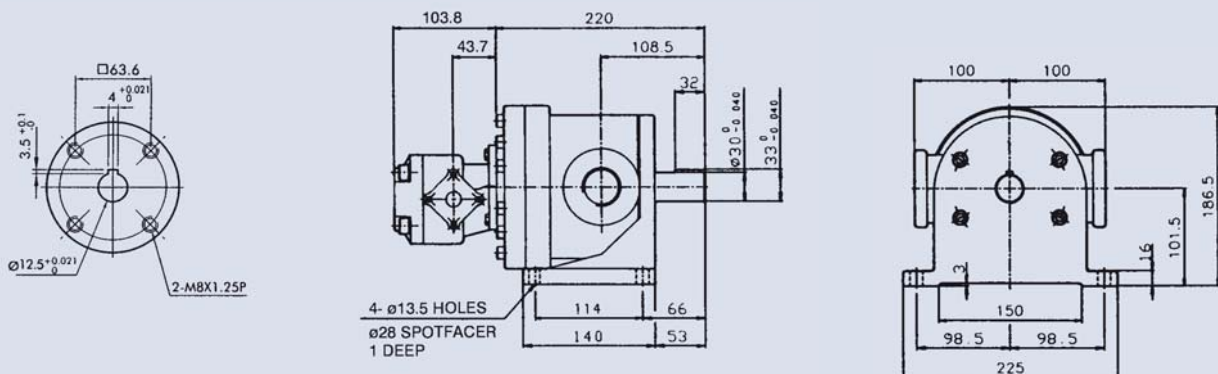

HVP-FAI FIXED DISPLACEMENT VANE PUMP

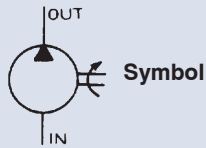

How to order

HVP-FAI - F - 11 - R

1 2 3 4

- 1 Low pressure single vane pump
- 2 Mounting type F: Flange type (normal) L: Foot type
- 3 Displacement
- 4 Shaft rotation (viewed from shaft end) R: Clockwise L: Counter-clockwise

Specifications

Model	Max. Pressure (bar)	Operating Characteristics At 1200 rpm With 20cst Fluid						Running Speed (rpm)		Ports Size (pt)		Weight (kg)	
		Delivery (lpm)			Input (kw)			Min.	Max.	Out	In	Foot Type	Flange Type
		5 bar	35 bar	70 bar	5 bar	35 bar	70 bar						
HVP-FAI-F5R	70	5.1	4.6	3.7	0.1	0.5	1.0	900	1800	3/8	1/2	6.5	5.6
HVP-FAI-F8R	70	9.7	8.9	7.7	0.1	0.8	1.5	900	1800	3/8	1/2	6.5	5.6
HVP-FAI-F11R	70	13.8	12.8	11.7	0.2	1.0	2.1	900	1800	3/8	1/2	6.5	5.6
HVP-FAI-F13R	70	14.9	13.8	12.8	0.2	1.3	2.5	900	1800	3/8	1/2	6.5	5.6

Dimensions

HVP-FAI-L

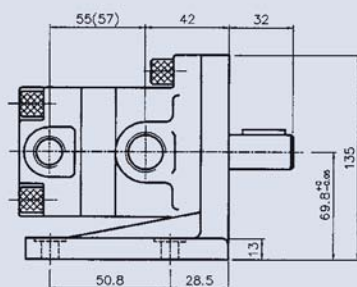

FOOT TYPE

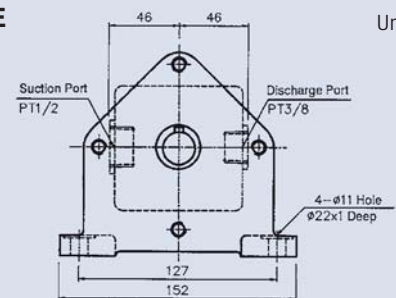

Unit:mm

HVP-FAI-F

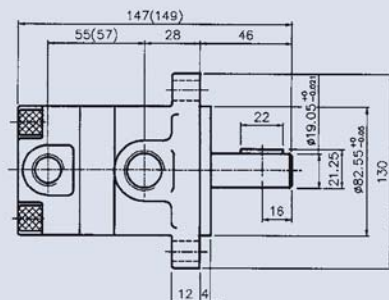

FLANGE TYPE

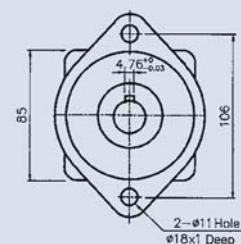

() FOR HVP-FAI-13R

FIXED DISPLACEMENT HI-PRESSURE SINGLE VANE PUMP

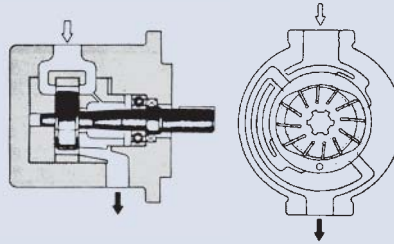
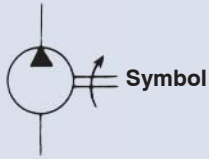

How to order

PV2R1 - 25 - F - R - A - A

1 2 3 4 5 6

1	Model	PV2R1, PV2R2, PV2R3, PV2R4 (see page 92 VQ-45)
2	Displacement cc/rev	
3	Mounting type	F: Flange type (normal) L: Foot type
4	Shaft rotation (viewed from shaft end)	R: Clockwise L: Counter-clockwise
5	Discharge port	A: Upward (normal) B: Downward R: Right side L: Left side
6	Suction port	A: Upward (normal) B: Downward R: Right side L: Left side

Specifications

Model	Delivery (cc/rev)	Max. Pressure (bar)	Running Speed (rpm)		Weight (kg)		Model	Delivery (cc/rev)	Max. Pressure (bar)	Running Speed (rpm)		Weight (kg)	
			Max.	Min.	Flange Type	Foot Type				Max.	Min.	Flange Type	Foot Type
PV2R1-06	5.8	210	1800	750	9	11.2	PV2R2-47	47.2	210	1800	600	19	23.3
PV2R1-08	8						PV2R2-53	52.3					
PV2R1-10	9.4						PV2R2-59	58.2					
PV2R1-12	12.2						PV2R2-65	64.7					
PV2R1-14	13.7						PV2R3-60	60.3					
PV2R1-17	16.6						PV2R3-66	66.4					
PV2R1-19	18.6						PV2R3-76	76.4					
PV2R1-23	22.7						PV2R3-82	82.2					
PV2R1-25	25.3						PV2R3-88	88.3					
PV2R1-31	31						PV2R3-94	93.6					
PV2R2-26	26.2	210	600	19	23.3	PV2R3-108	108.2						
PV2R2-33	33					PV2R3-116	115.6						
PV2R2-38	38					PV2R3-126	125.6						
PV2R2-41	41.3												

Dimensions

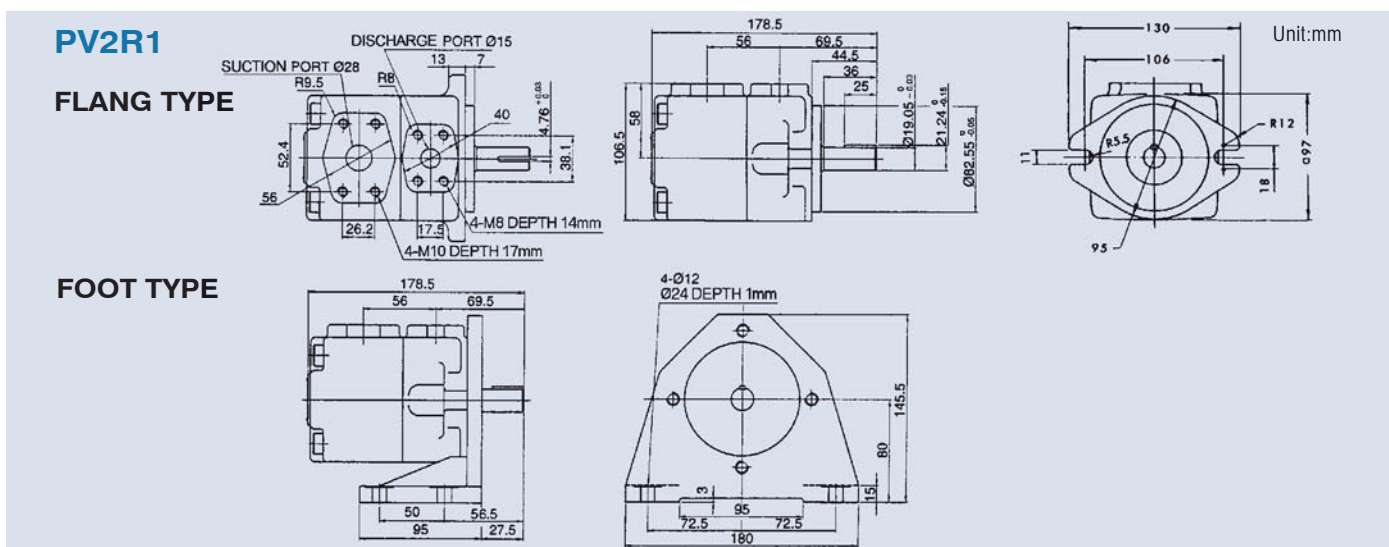

FIXED DISPLACEMENT HI-PRESSURE SINGLE VANE PUMP

Dimensions

PV2R2

FLANGE TYPE

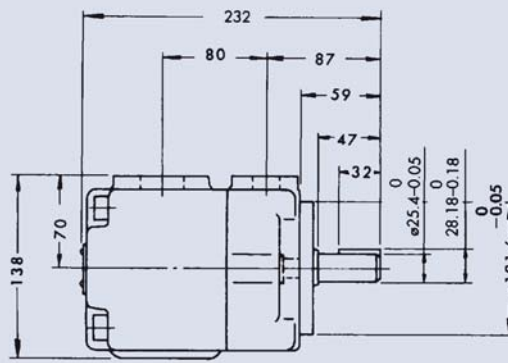
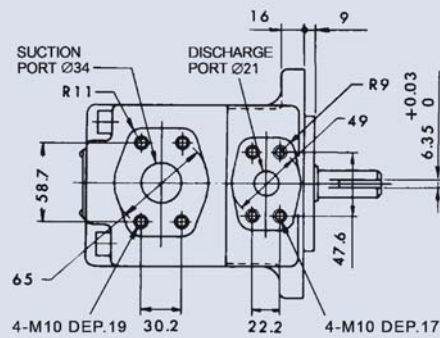

Unit:mm

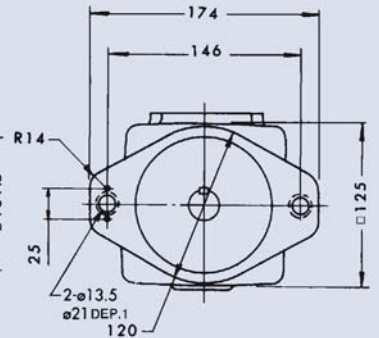

FOOT TYPE

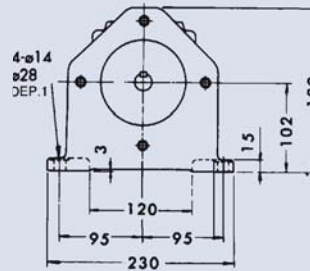
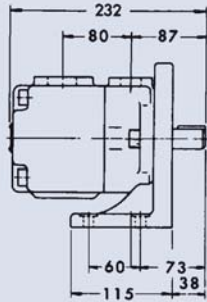

PV2R3

FLANGE TYPE

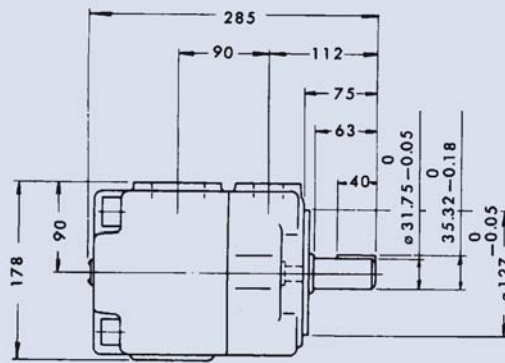
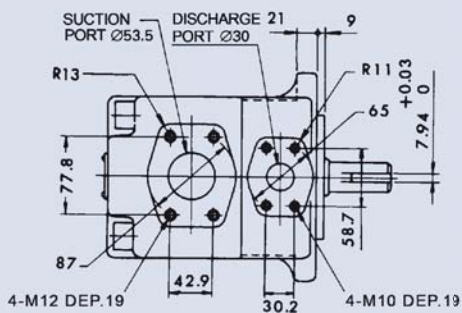

Unit:mm

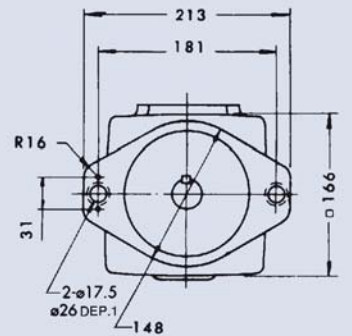

FOOT TYPE

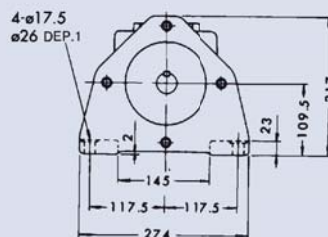
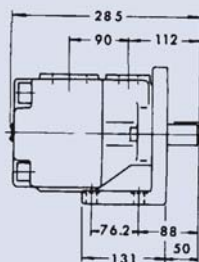

FIXED DISPLACEMENT HI-PRESSURE SINGLE VANE PUMP

Decomposition Chart

PV2R1

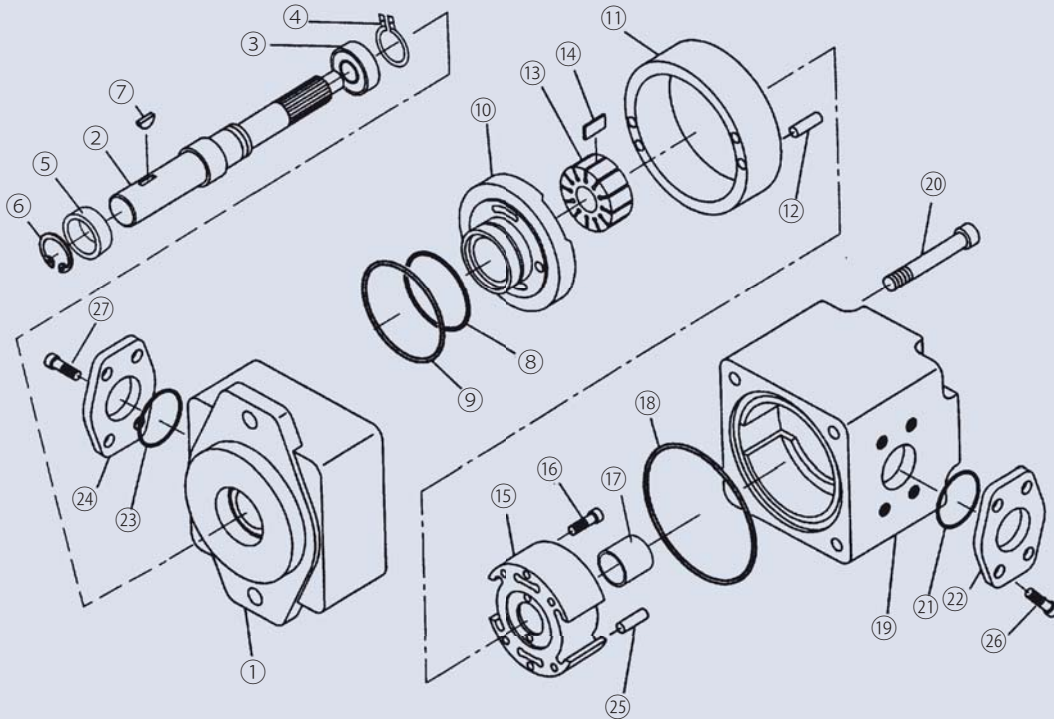

PV2R2 PV2R3

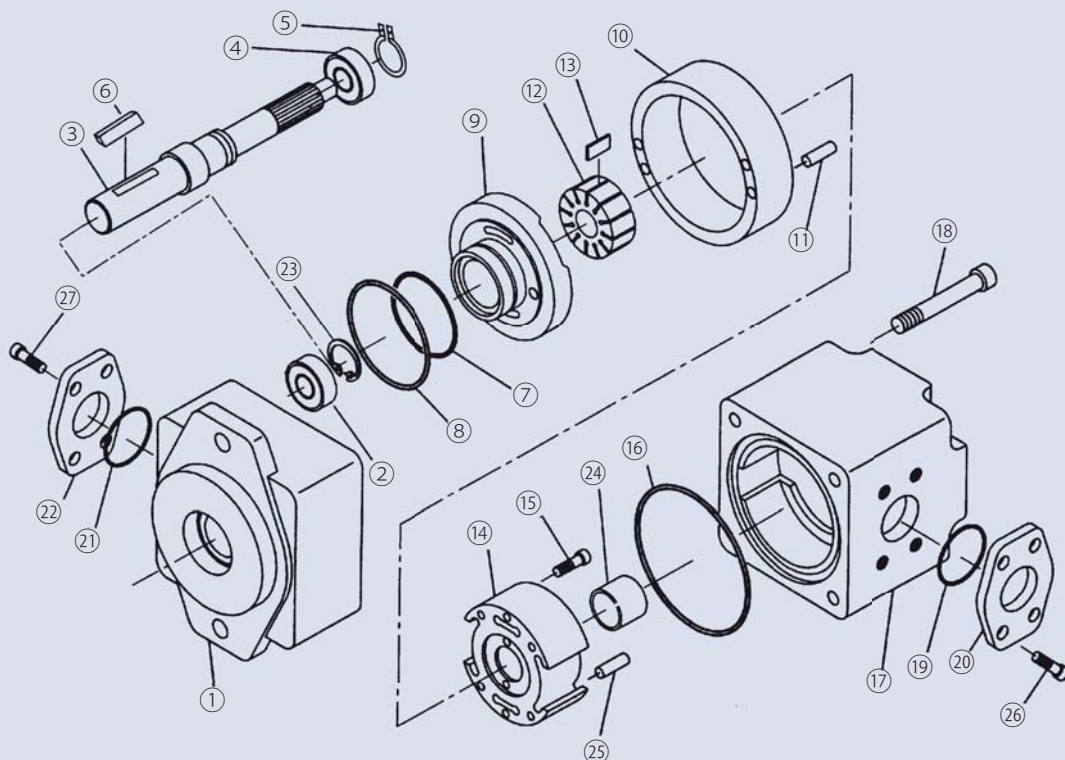

FIXED DISPLACEMENT HI-PRESSURE DOUBLE VANE PUMP

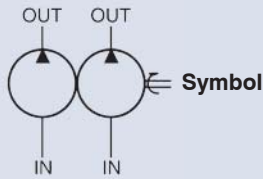

How to order

PV2R12, PV2R23 - ❄ - ❄ - F - R - A - A - A

	1	2	3	4	5	6	7	8
1	Model	PV2R12 (P1: PV2R2, P2: PV2R1)	PV2R13 (P1: PV2R3, P2: PV2R1)	PV2R23 (P1: PV2R3, P2: PV2R2)				
2	P1: Displacement cc/rev (see page 83)							
3	P2: Displacement cc/rev (see page 83)							
4	Mounting type	F: Flange type (normal)	L: Foot type					
5	Shaft rotation (viewed from shaft end)	R: Clockwise	L: Counter-clockwise					
6	P1: Discharge port	A: Upward (normal)	B: Downward	R: Right side	L: Left side			
7	Suction port	A: Upward (normal)	B: Downward	R: Right side	L: Left side			
8	P2: Discharge port	A: Upward (normal)	B: Downward	R: Right side	L: Left side	E: Left upward 45°		

Dimensions

PV2R12 FLANGE TYPE

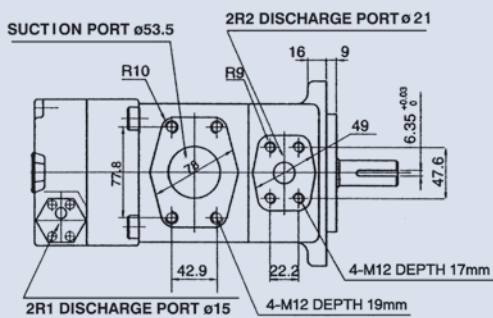

FOOT TYPE

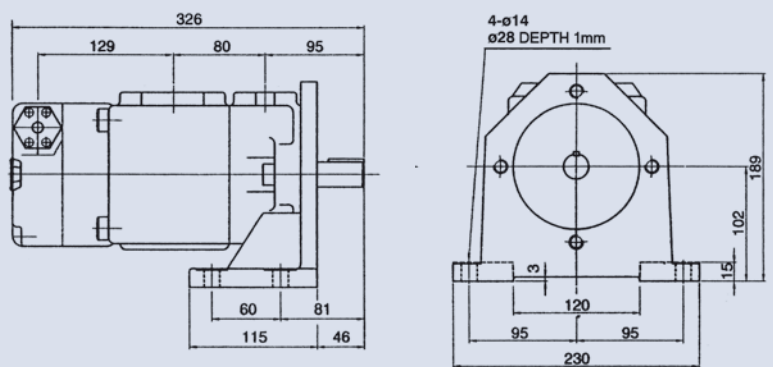

Unit:mm

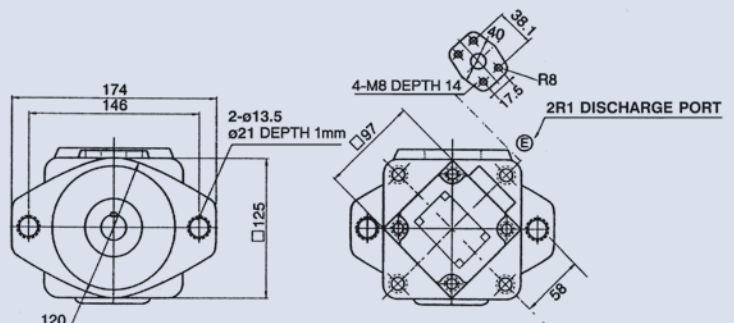
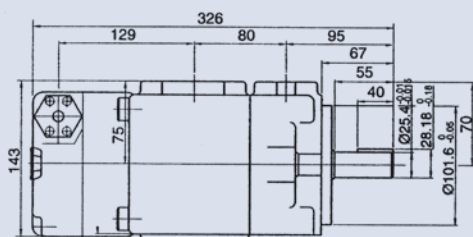

FIXED DISPLACEMENT HI-PRESSURE SINGLE VANE PUMP

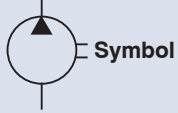

How to order

VQ25 - 18 - F - R - A - A - 01

1	2	3	4	5	6	7
1	Model					
2	Displacement cc/rev					
3	Mounting type F: Flange type (normal) L: Foot type					
4	Shaft rotation (viewed from shaft end) R: Clockwise L: Counter-clockwise					
5	Discharge port (viewed from shaft end) A: Upward (normal) B: Downward R: Right side L: Left side					
6	Suction port (viewed from shaft end) A: Upward (normal) B: Downward R: Right side L: Left side					
7	Shaft type 01: Normal					

Specifications

Model	Displacement (cc/rev)	Delivery At No-load Pressure (lpm)				Running Speed (rpm)		Max. Pressure (bar)	Weight (kg)					
		Running Speed (rpm)				Max.	Min.		Flange Type	Foot Type				
		1000	1200	1500	1800									
VQ15	06	6.2	7.4	9.3	11.2	1800	1200	230	10.3	12.7				
	08	8.1	9.7	12.1	14.6									
	11	11.2	13.4	16.8	20.1									
	14	14.3	17.1	21.5	25.7									
VQ20	17	17.1	20.5	25.6	30.7	1800	800	230	16.7	21.4				
	19	19.2	23	28.8	34.5									
	23	23.3	27.9	34.9	41.9									
	26	26.1	31.1	39.1	46.9									
VQ25	31	31.1	37.3	46.6	—	1500	200	230	23	31				
	38	38.1	45.6	—	—	1200								
	18	18.1	21.7	27.2	32.6	1800					600	200	36	44
	22	22.1	26.5	33.2	39.8									
26	26.2	31.4	39.3	47.1										
32	32.1	38.5	48.1	57.7										
SVQ25	38	38.2	45.8	57.3	68.7	1500	600	200	52	60				
	43	43.2	51.8	64.8	77.7									
	47	47.1	56.5	70	85									
	52	52.3	62.7	78.4	94.1									
VQ35	60	60.2	72.7	90.3	108.3	1800	1200	230	23	31				
	65	65.3	78.3	97.9	117.5									
	75	75	90	112.5	—									
	60	60.3	72.3	90.4	108.5						1800	600	200	33
66	66.4	79.6	99.6	119.5										
76	76.3	91.5	114.4	137.3										
82	82.2	98.6	123.3	147.9										
SVQ35	88	88.3	105.9	132.4	158.9	1500	600	200	66.5	94.5				
	94	94.5	113.4	141.7	170.1									
	108	108.2	129.8	162.3	194.4									
	116	116.1	139.3	174.1	208.9									
VQ45	125	124.6	149.5	186.9	—	1800	1200	230	61	89				
	136	136.8	164	204	246									
SVQ45	156	156.2	188	234	280	1500	600	200	52	60				
	189	189.5	227	284	340									
DVQ45	200	200	240	300	360	1800	1200	230	66.5	94.5				
	216	216	260	324	—									
DVQ45	237	237	285	355	—	1500	600	200	61	89				
	237	237	285	355	—									

FIXED DISPLACEMENT HI-PRESSURE SINGLE VANE PUMP

Dimensions

VQ15

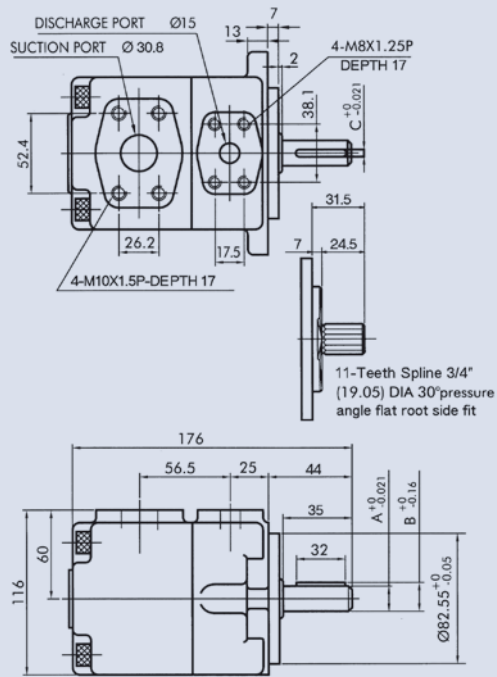

FOOT TYPE

Unit:mm

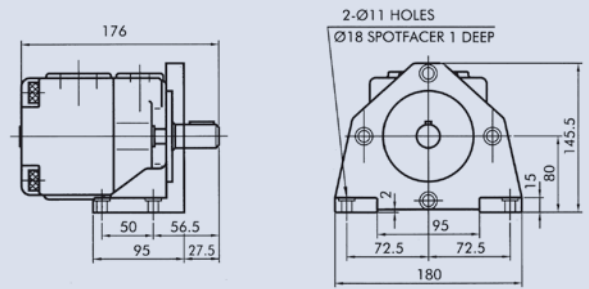

	A	B	C
NO.01-Shaft	$\varnothing 19.05$	21.24	4.76
NO.03-Shaft	Spline shaft		

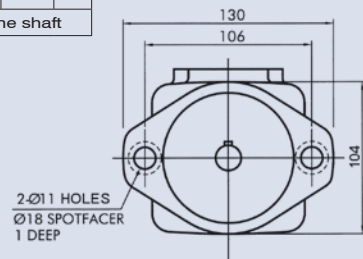

VQ20

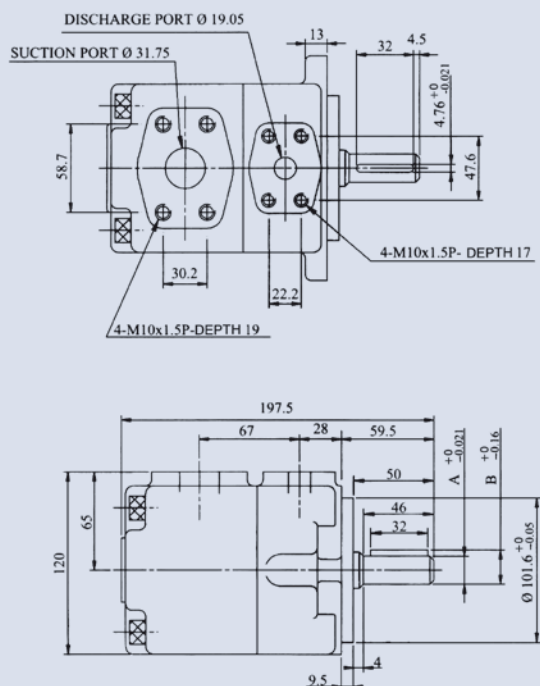

FOOT TYPE

Unit:mm

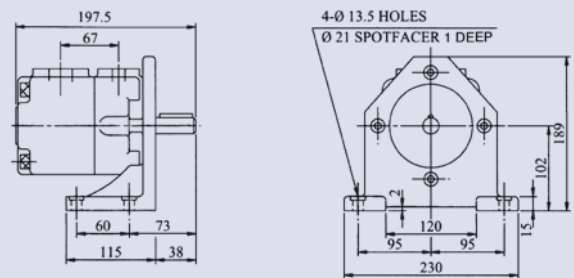

	A	B	C
NO.01-Shaft	$\varnothing 22.23$	24.5	4.76
NO.02-Shaft	$\varnothing 25.4$	28.18	6.35
NO.03-Shaft	$\varnothing 22.23$	24.94	6.35

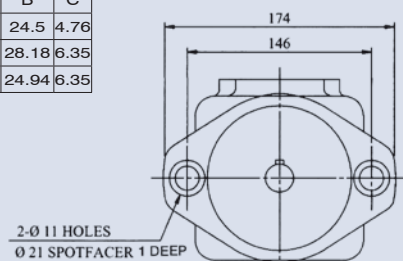

FIXED DISPLACEMENT HI-PRESSURE SINGLE VANE PUMP

Dimensions

VQ25

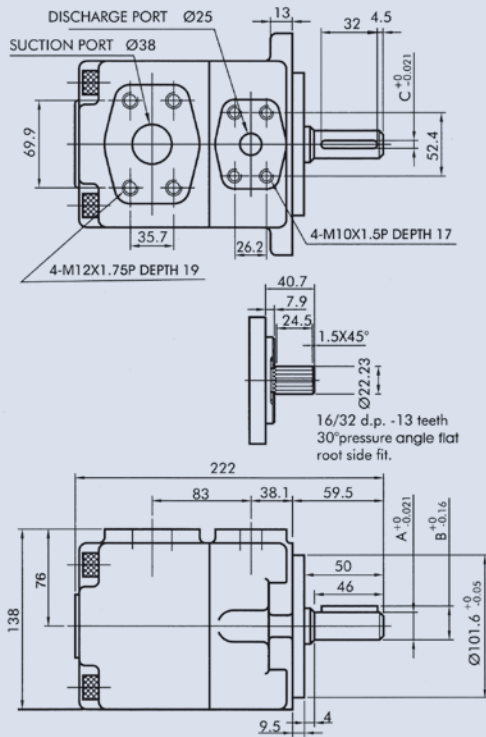

FOOT TYPE

Unit:mm

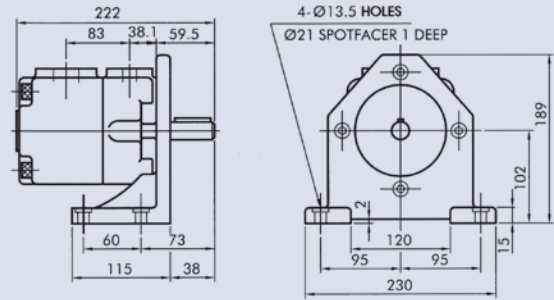

	A	B	C
NO.01-Shaft	ø22.23	24.5	6.35
NO.02-Shaft	ø25.4	28.18	6.35
NO.03-Shaft	ø30	33	7
NO.04-Shaft	Spline shaft		
NO.W-Shaft	ø28	30.8	6.35

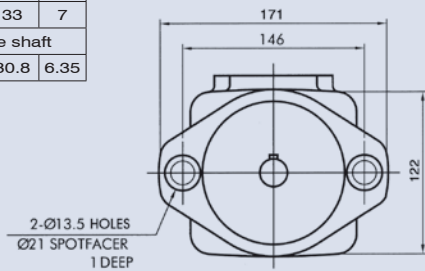

SVQ25

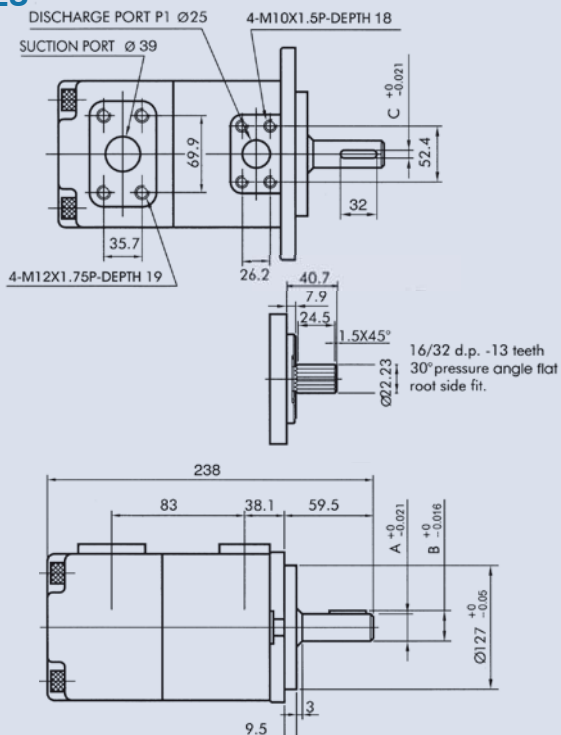

FOOT TYPE

Unit:mm

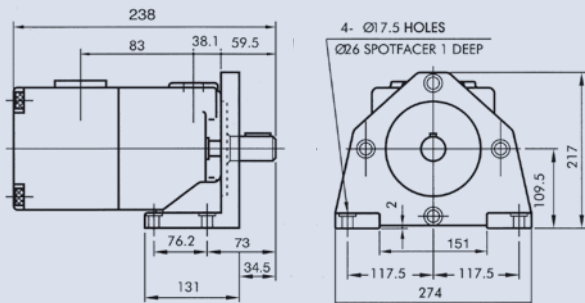

	A	B	C
NO.01-Shaft	ø22.23	24.5	6.35
NO.02-Shaft	ø25.4	28.18	6.35
NO.03-Shaft	ø30	33	7
NO.04-Shaft	Spline shaft		
NO.W-Shaft	ø28	30.8	6.35

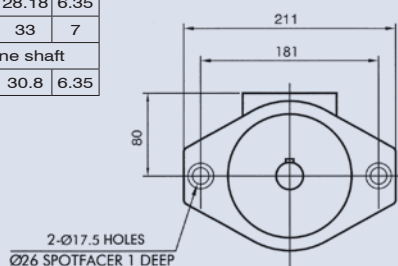

FIXED DISPLACEMENT HI-PRESSURE SINGLE VANE PUMP

Dimensions

VQ35

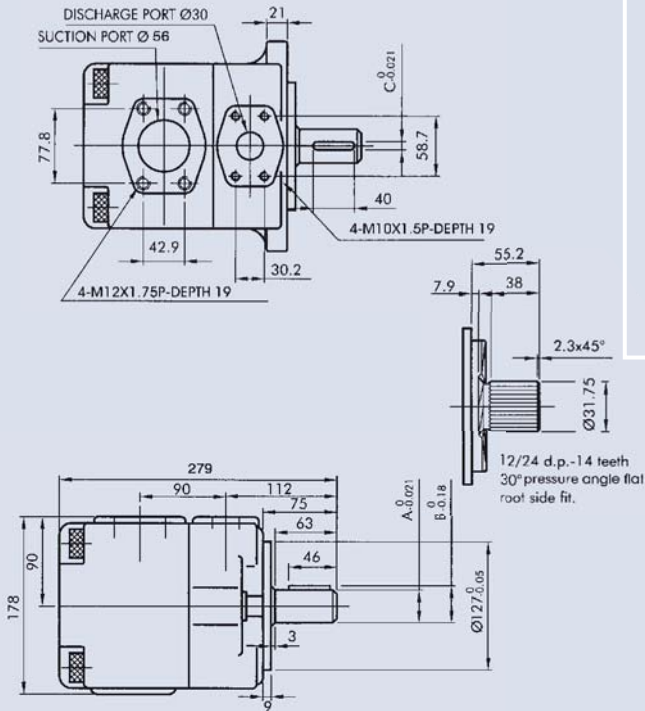

FOOT TYPE

Unit:mm

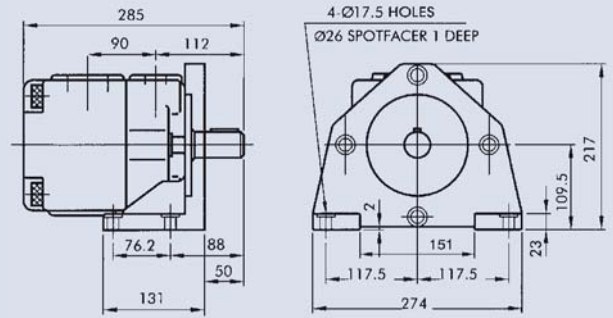

	A	B	C
NO.01-Shaft	ø31.75	35.32	7.95
NO.02-Shaft	ø34.9	38.56	7.95
NO.03-Shaft	Spline shaft		

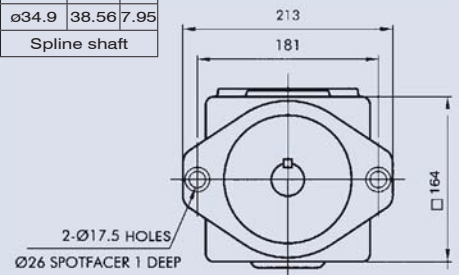

SVQ35

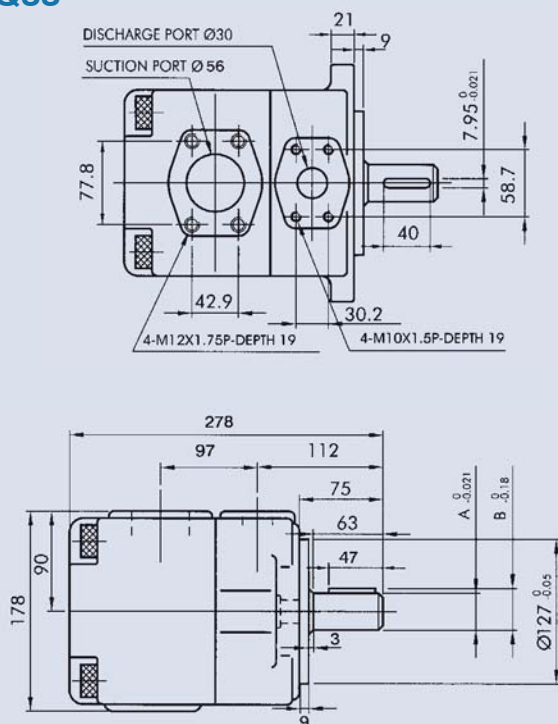

FOOT TYPE

Unit:mm

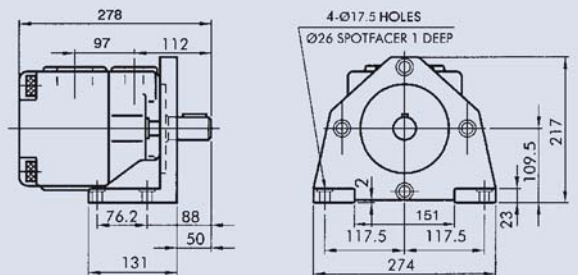

	A	B
NO.01-Shaft	ø31.75	35.32
NO.02-Shaft	ø34.9	38.56

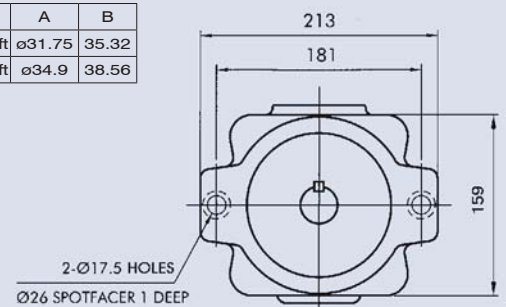

FIXED DISPLACEMENT HI-PRESSURE SINGLE VANE PUMP

Dimensions

SVQ45

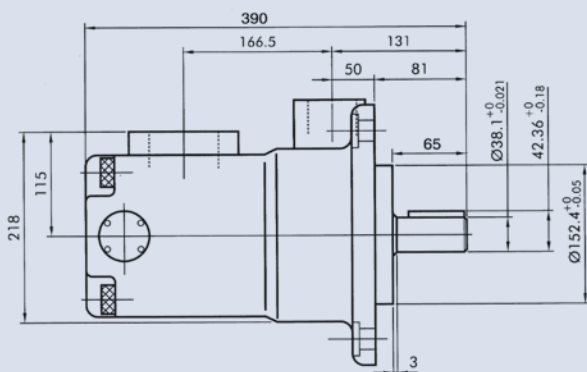
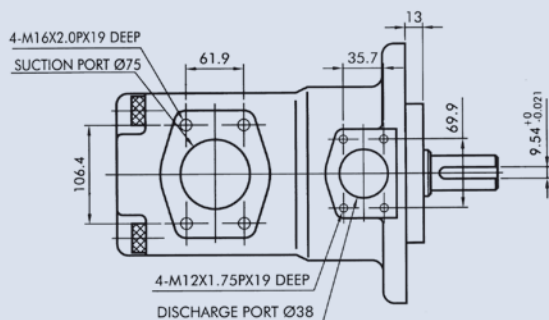

FOOT TYPE

Unit:mm

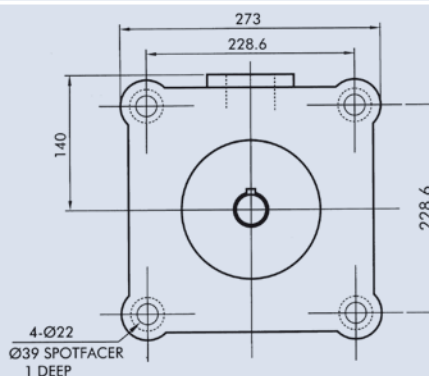
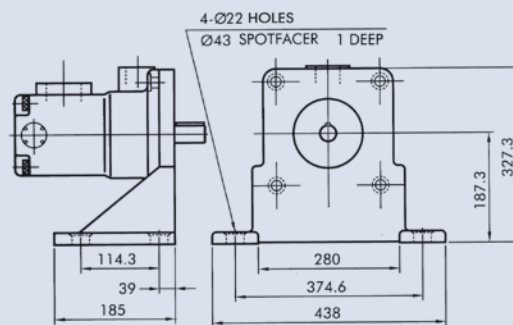

Parts list

Item No.	Description	VQ15	VQ25 (SVQ25)	VQ35 (SVQ35)	VQ45 (SVQ45)
1	Retainer Ring	R47	R52	R72	R85
2	Seal	22x47x7	30x52x11	(VQ35) 35x55x11 (SVQ35) 38x72x12	50x85x10
3	Bearing	6204	6205	6207	6209
4	Shaft				
5	Key				
6	Housing				
7	Cartridge Kit				
8	O-Ring	G85	G100	G135	G140
9	Cover				
10	Cap-Screw	M10x1.5x85	(VQ25) M12x1.75x110 (SVQ25) M12x1.75x120	M16x2.0x130	(VQ45) M16x2.0x160 (SVQ45) M20x2.5x160
11	O-ring & Endless Back-up Ring	P36	P46	65.5x3.5	G80
12	O-ring & Endless Back-up Ring	71.5x3.5	90.2x3.5	G115	G130

FIXED DISPLACEMENT HI-PRESSURE SINGLE VANE PUMP

Decomposition Chart

VQ15
VQ25
VQ35
VQ45

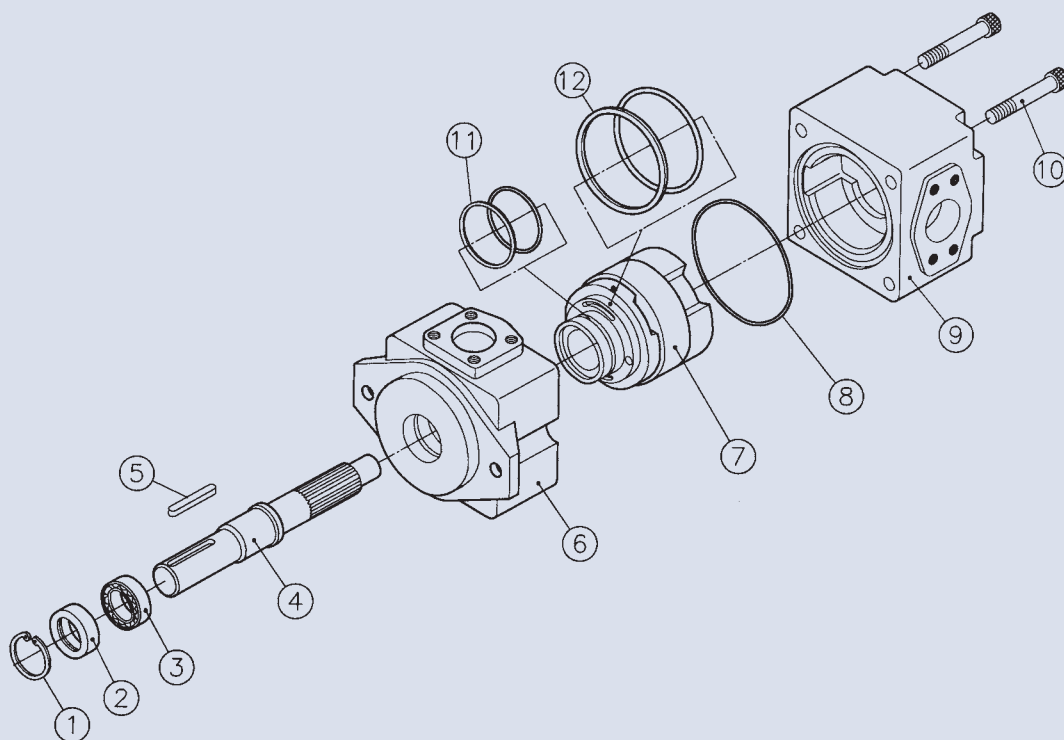

SVQ25
SVQ35
SVQ45 (DVQ45)

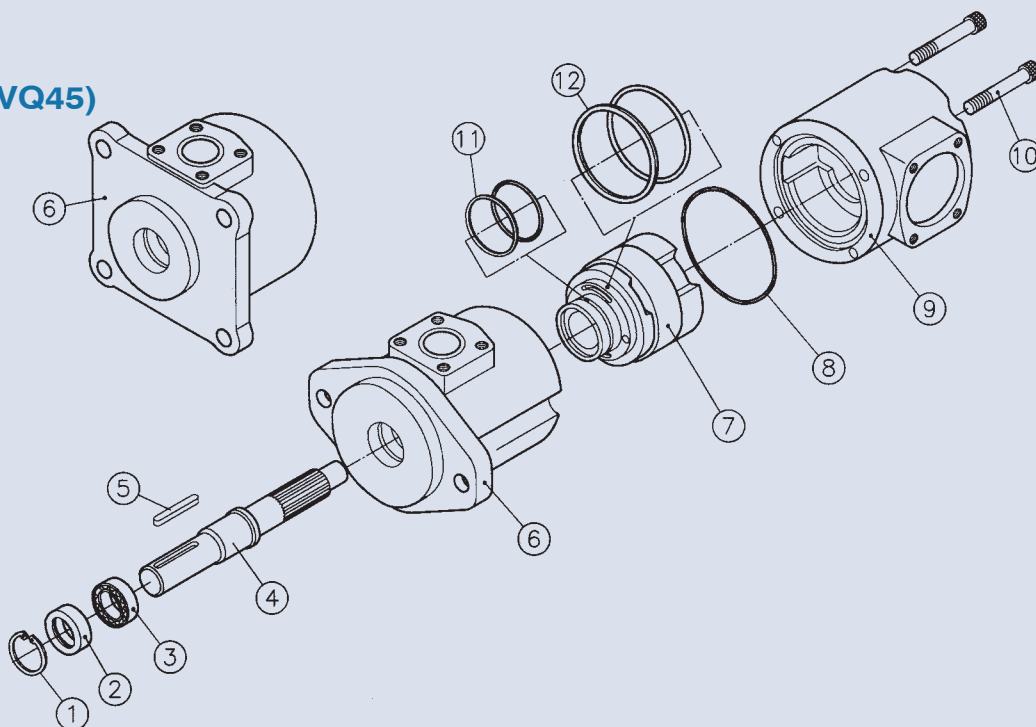

FIXED DISPLACEMENT HI-PRESSURE SINGLE VANE PUMP

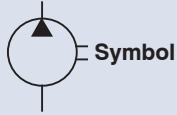

How to order

HVQ20, DVQ20 - 4 - F - R - A - A - 01

	1	2	3	4	5	6	7
1	Model						
2	Displacement cc/rev						
3	Mounting type F: Flange type L: Foot type						
4	Shaft rotation (viewed from shaft end) R: Clockwise L: Counter-clockwise						
5	Discharge port A: Upward (normal) B: Downward R: Right side L: Left side						
6	Suction port A: Upward (normal) B: Downward R: Right side L: left side						
7	Shaft type 01: Normal						

Specifications

Model	Displacement (cc/rev)	Max. Pressure (bar)		Running speed (rpm)		Weight (kg)			
		Cont.	Peak	Max.	Min.	Flange type	Foot type		
HVQ20	4	420	480	3000	800	18.1	23.1		
	6			2500					
	8			2300					
	11			1800					
	14	380	400	1800					
	17								
	19								
23	230	280	1800						
DVQ25				18	230	280	1800	18	23
				22					
				26					
				32					
				38					
				43					
				47					
				52					
60	250	1600							
65									
75									

FIXED DISPLACEMENT HI-PRESSURE SINGLE VANE PUMP

Dimensions

HVQ20

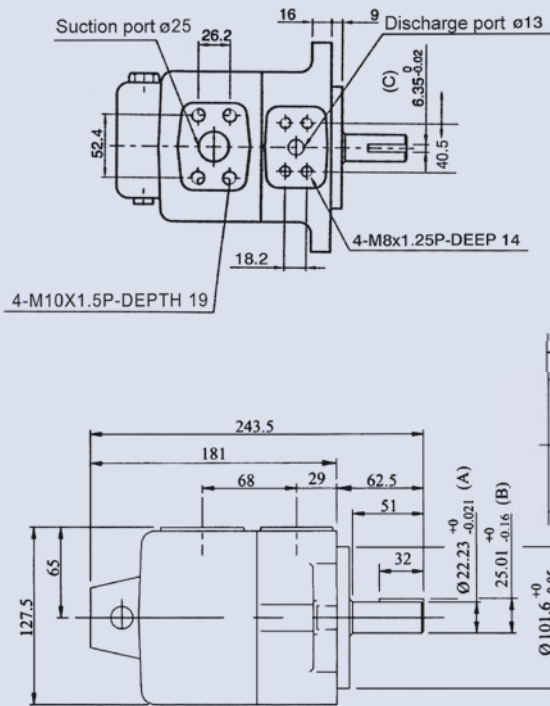

FOOT TYPE

Unit:mm

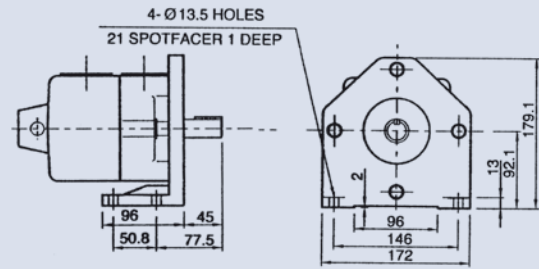

	A	B	C
NO.01-Shaft	ø22.23	25.01	6.35
NO.03-Shaft	Spline shaft		

Shaft Code 3

SAE B-B splined shaft
Class 1-J498 b 16/32 d.p.
-13 teeth 30° pressure
angle flat root side fit.

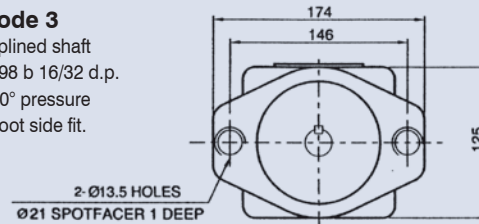

DVQ25

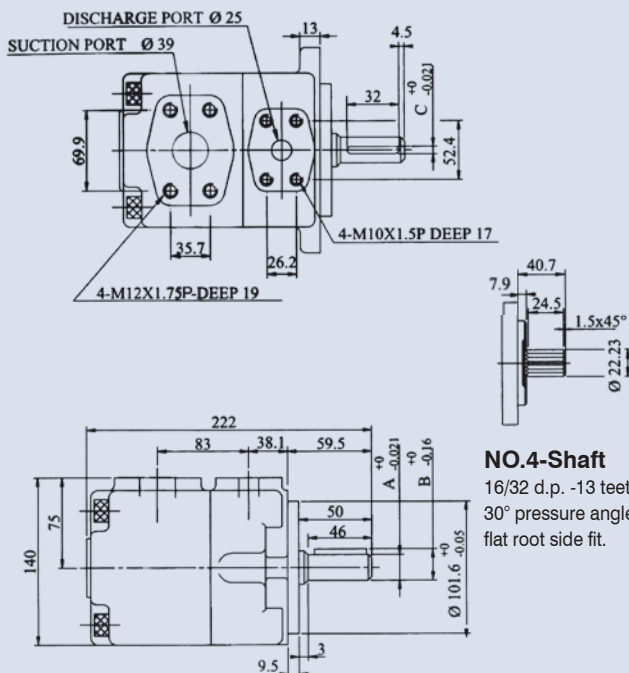

FOOT TYPE

Unit:mm

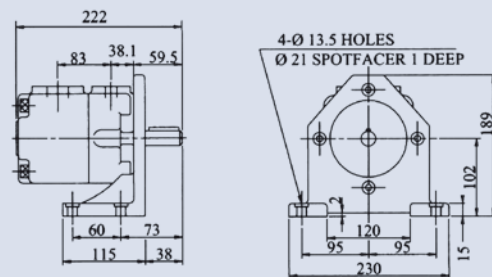

	A	B	C
NO.01-Shaft	ø22.23	24.5	6.35
NO.02-Shaft	ø25.4	28.18	6.35
NO.03-Shaft	ø30.0	33.0	7.0
NO.04-Shaft	Spline shaft		
NO.W-Shaft	ø28.0	30.8	6.35

NO.4-Shaft

16/32 d.p. -13 teeth
30° pressure angle
flat root side fit.

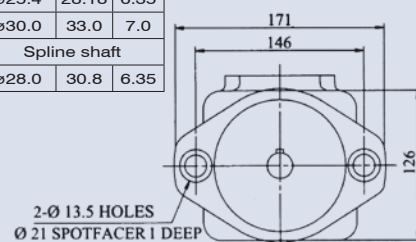

FIXED DISPLACEMENT HI-PRESSURE DOUBLE VANE PUMP

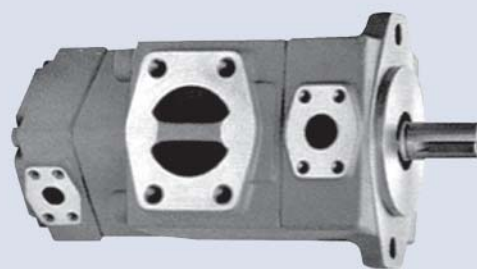
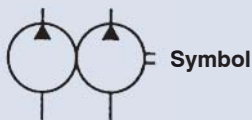

How to order

VQ215 - 18 - 6 - ✖ - R - A - A - A - ✖

1	Model
2	P1 Displacement cc/rev
3	P2 Displacement cc/rev
4	Mounting type F: Flange type (normal) L: Foot type
5	Shaft rotation (viewed from shaft end) R: Clockwise L: Counter-clockwise
6	P1: Discharge A: Upward (normal) B: Downward R: Right side L: Left side
7	Suction port A: Upward (normal) B: Downward R: Right side L: Left side
8	P2: Discharge port A: Upward (normal) B: Downward R: Right side L: Left side R1: Right upward 45° R2: Right downward 45° L1: Left upward 45° L2: Left downward 45°
9	Shaft type

Specifications

Model	P1: Displacement (cc/rev)	P2: Displacement (cc/rev)	Max. Pressure (bar)	Weight (kg)	
				Flange Type	Foot Type
VQ215	18,22,26,32,38,43,47,52,60,65,75	6,8,11,14,17,19,23,26,31,38	245	24	29
SVQ215				32	40
VQ225	18,22,26,32,38,43,47,52,60,65,75	30.6		35.5	
VQ315		48		55	
SVQ315	60,66,76,82,88,94,108,116,125	44.4		52	
VQ325		50		58	
VQ425	136,156,189,200,216,237	18,22,26,32,38,43,47,52,60,65,75		63	71
SVQ425				80	111
DVQ425				73	104
VQ435				76	93
SVQ435	136,156,189,200,216,237	60,66,76,82,88,94,108,116,125	91	122	
DVQ435			84	115	

FIXED DISPLACEMENT HI-PRESSURE DOUBLE VANE PUMP

Dimensions

VQ215

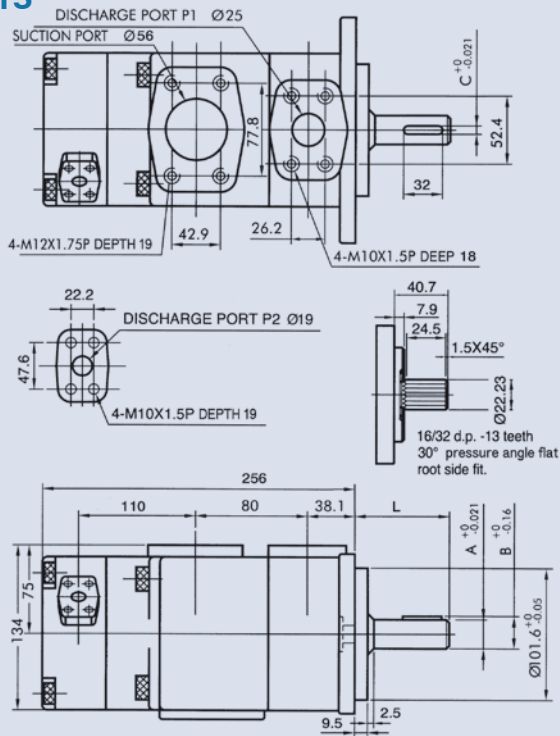

FOOT TYPE

Unit:mm

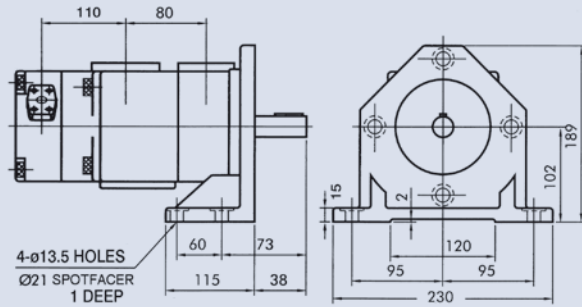

	A	B	C	L
NO.01-Shaft	Ø22.23	24.5	6.35	61
NO.02-Shaft	Ø25.4	28.18	6.35	61
NO.03-Shaft	Ø30	33	7	68
NO.04-Shaft	Spline shaft 7/8"			

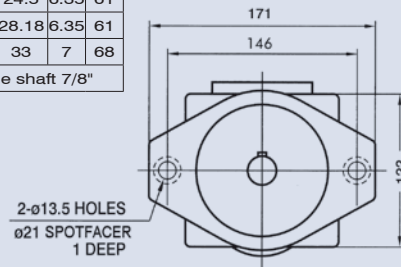

SVQ215

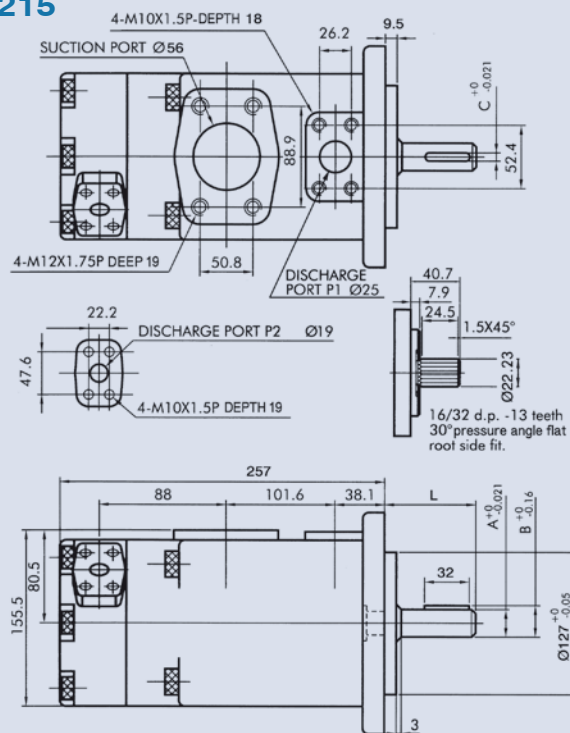

FOOT TYPE

Unit:mm

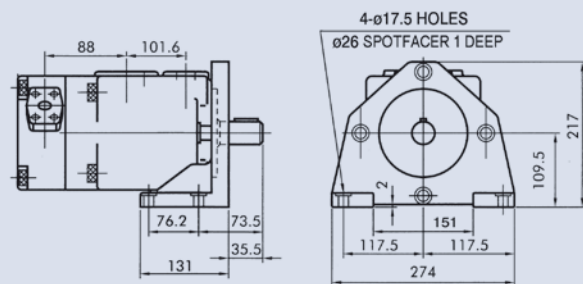

	A	B	C	L
NO.01-Shaft	Ø22.23	24.5	6.35	61
NO.02-Shaft	Ø25.4	28.18	6.35	61
NO.03-Shaft	Ø30	33	7	68
NO.04-Shaft	Spline shaft 7/8"			

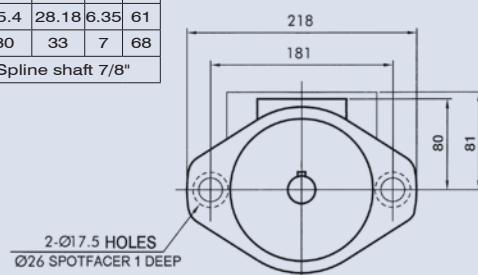

FIXED DISPLACEMENT HI-PRESSURE DOUBLE VANE PUMP

Dimensions

VQ225

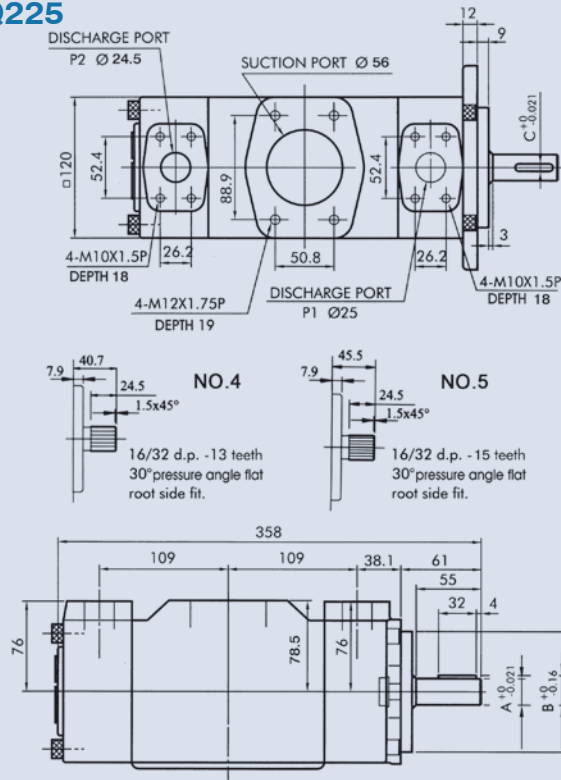

FOOT TYPE

Unit:mm

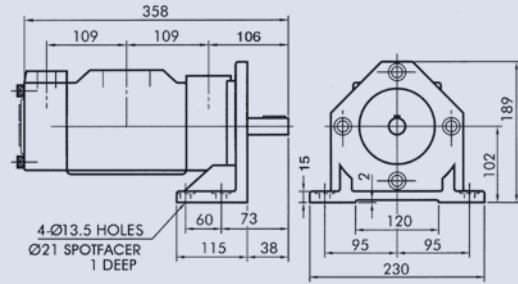

	A	B	C
NO.01-Shaft	ø22.23	24.5	6.35
NO.02-Shaft	ø25.4	28.18	6.35
NO.03-Shaft	ø30	33	7
NO.04-Shaft	Spline shaft 7/8"		
NO.05-Shaft	Spline shaft 1"		

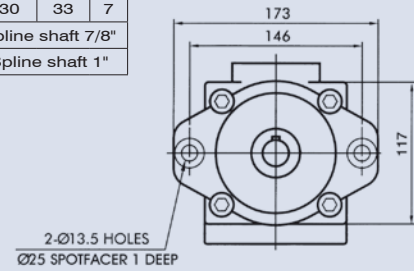

VQ315

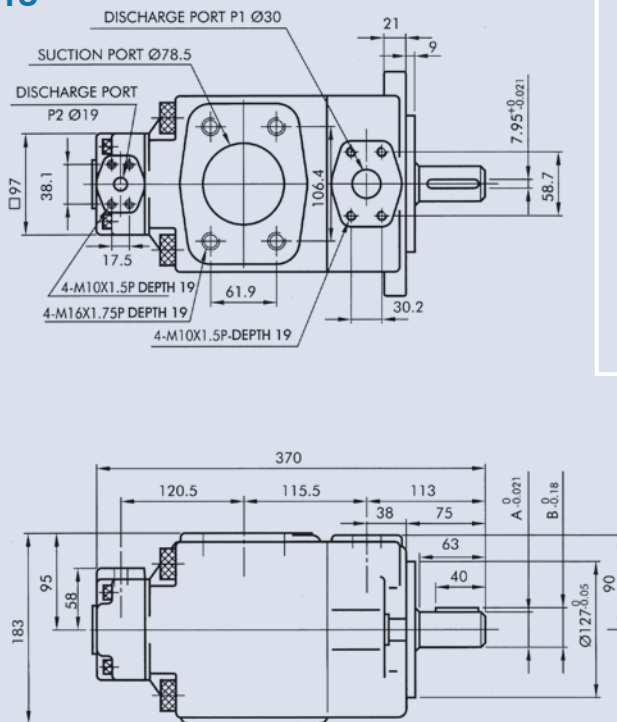

FOOT TYPE

Unit:mm

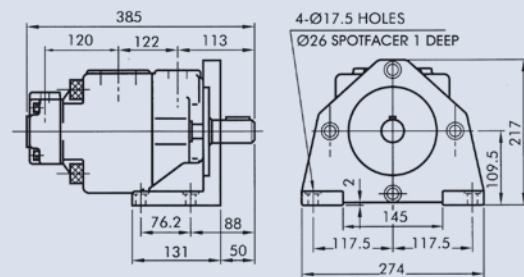

	A	B
NO.01-Shaft	ø31.75	35.32
NO.02-Shaft	ø34.9	38.56

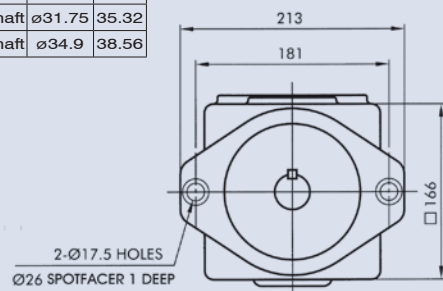

FIXED DISPLACEMENT HI-PRESSURE DOUBLE VANE PUMP

Dimensions

SVQ315

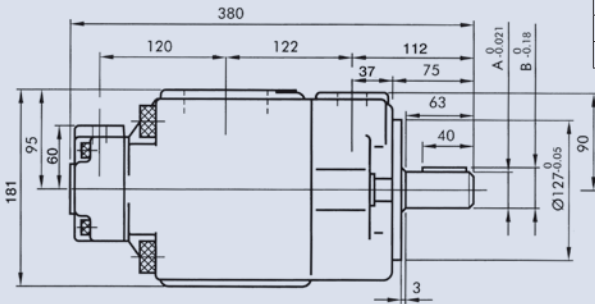
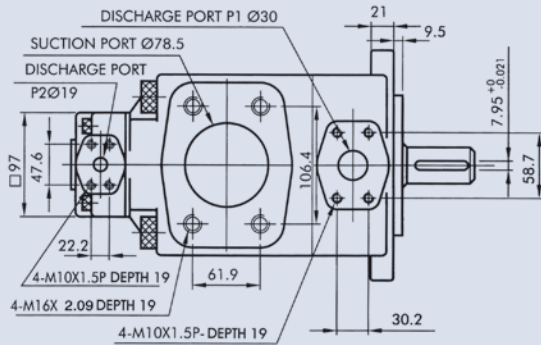

FOOT TYPE

Unit:mm

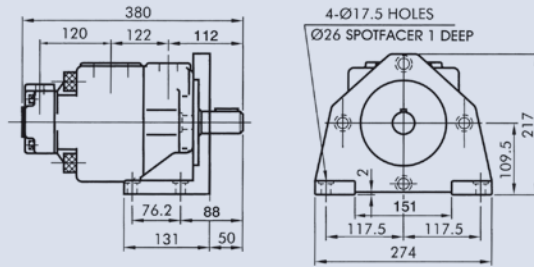

	A	B
NO.01-Shaft	ø31.75	35.32
NO.02-Shaft	ø34.9	38.56

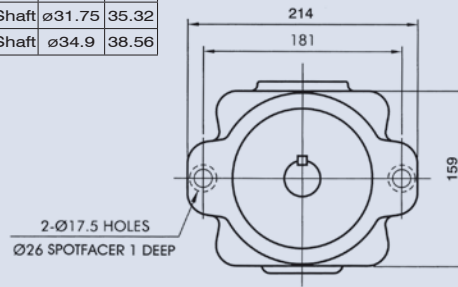

VQ325

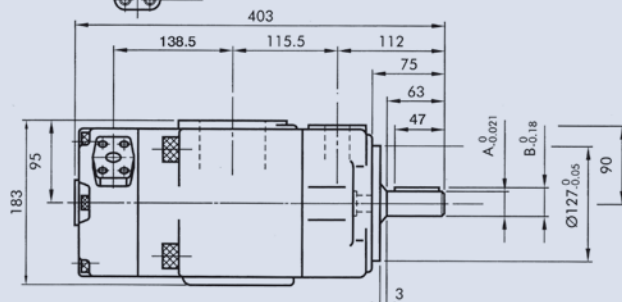
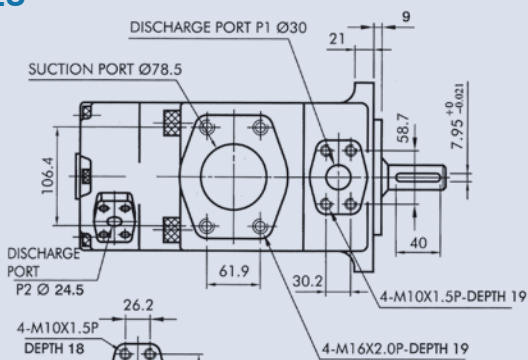

FOOT TYPE

Unit:mm

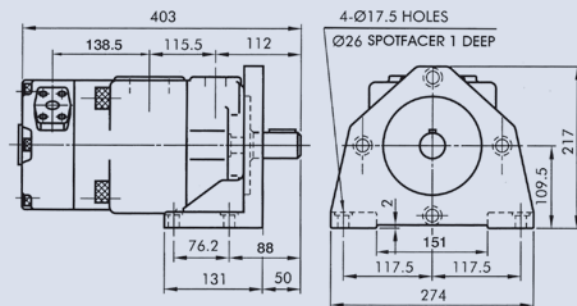

	A	B
NO.01-Shaft	ø31.75	35.32
NO.02-Shaft	ø34.9	38.56

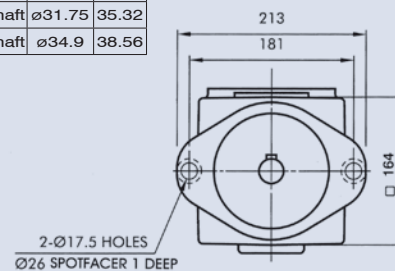

FIXED DISPLACEMENT HI-PRESSURE DOUBLE VANE PUMP

Dimensions

VQ425

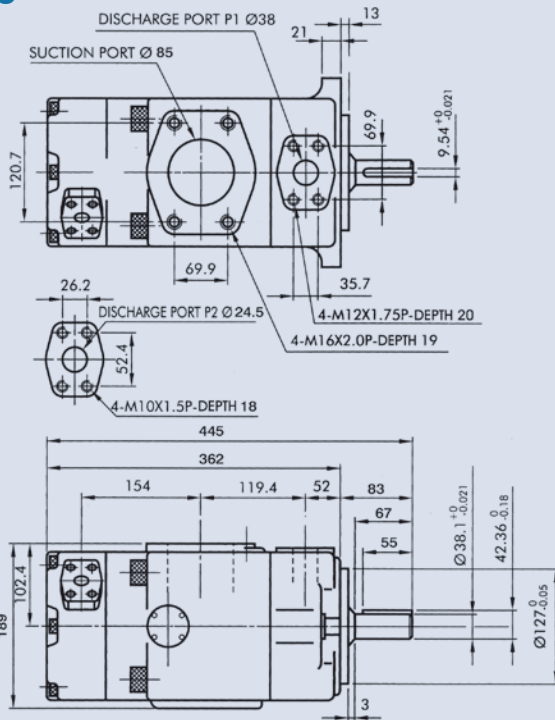

FOOT TYPE

Unit:mm

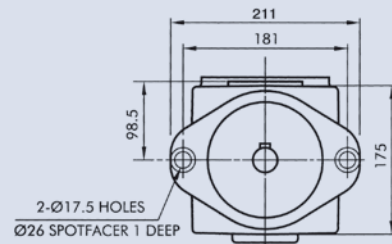
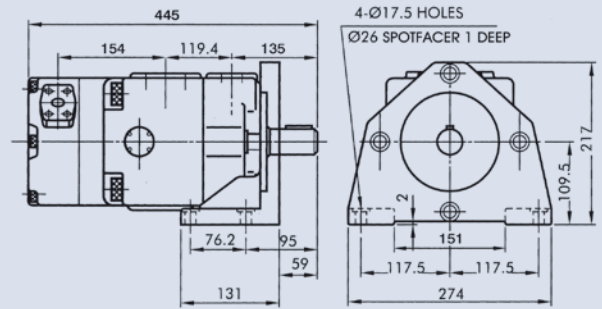

SVQ425

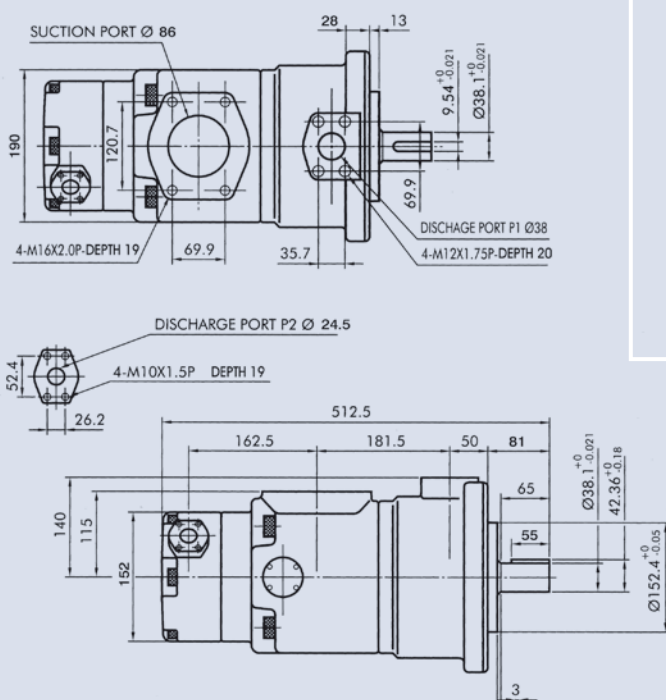

FOOT TYPE

Unit:mm

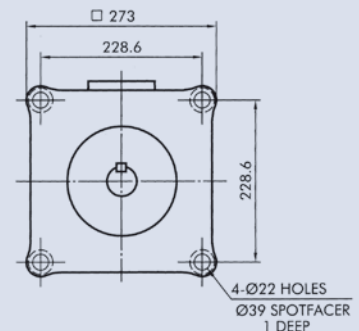
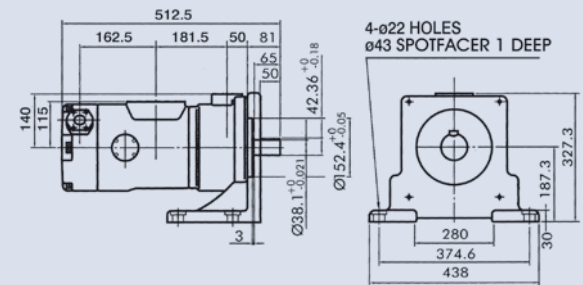

FIXED DISPLACEMENT HI-PRESSURE DOUBLE VANE PUMP

Dimensions

DVQ425

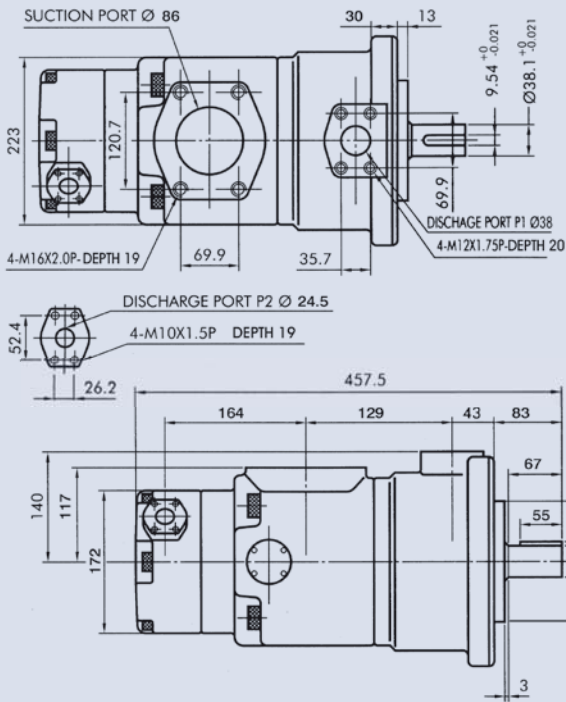

FOOT TYPE

Unit:mm

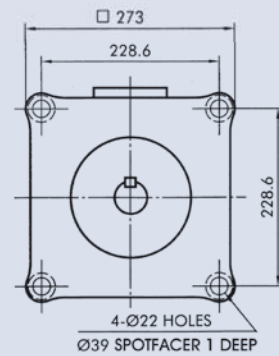
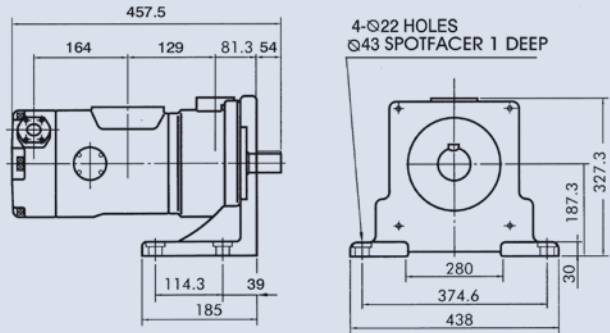

VQ435

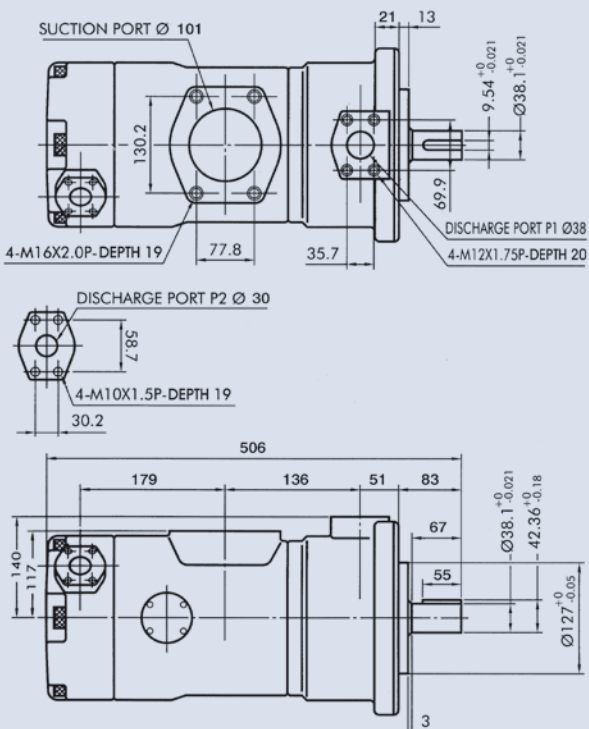

FOOT TYPE

Unit:mm

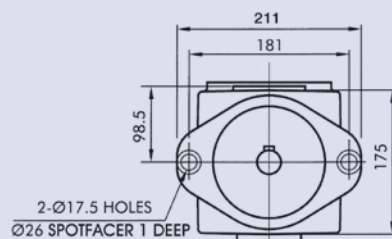
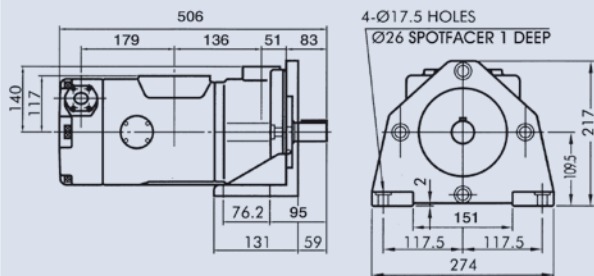

FIXED DISPLACEMENT HI-PRESSURE DOUBLE VANE PUMP

Dimensions

SVQ435

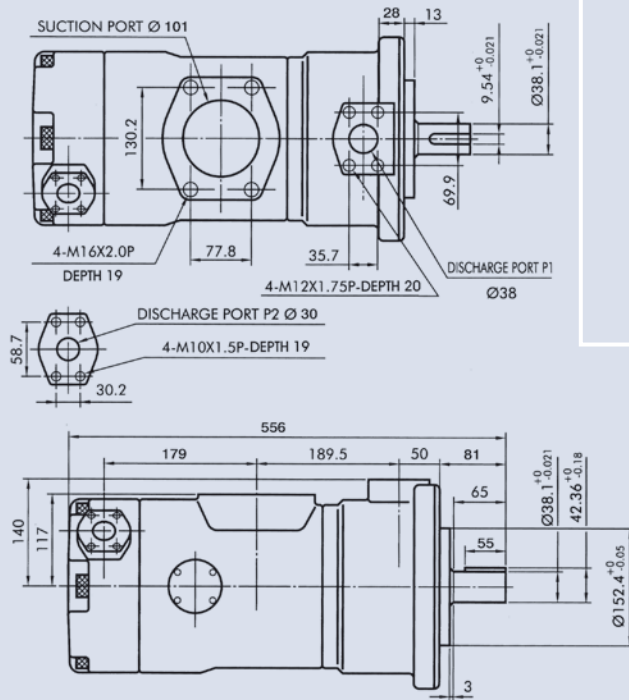

FOOT TYPE

Unit:mm

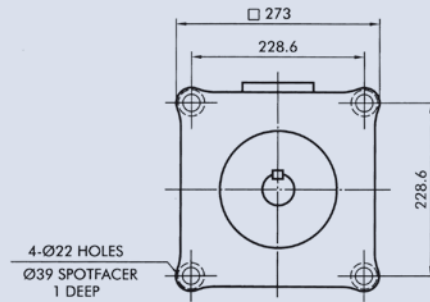
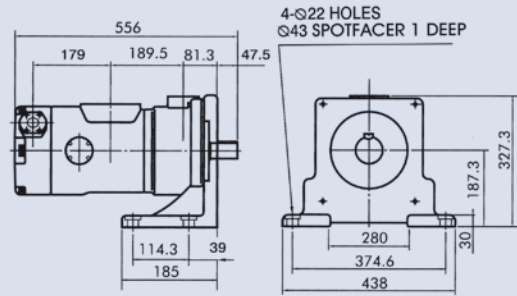

DVQ435

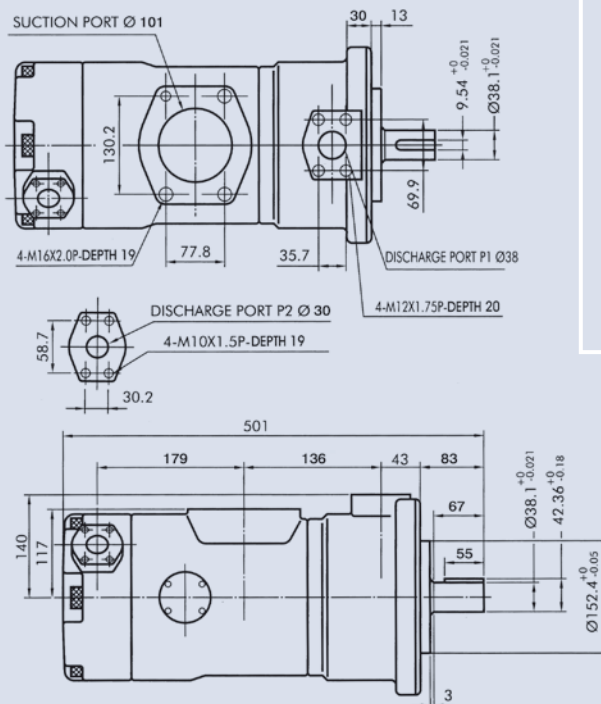

FOOT TYPE

Unit:mm

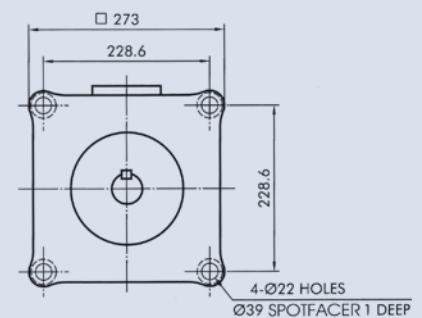
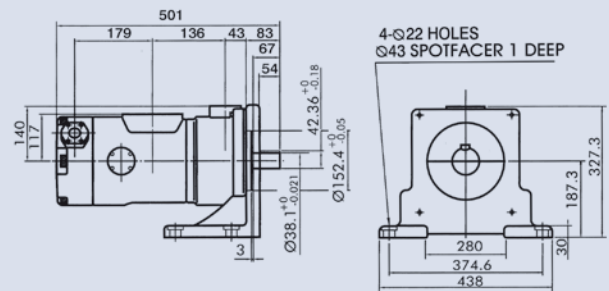

DOUBLE LIPS AND PISTON TYPE SINGLE VANE PUMP

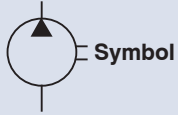

How to order

KT6C, KT6D, KT6E - 014 - 1 R 00 - B 1

	1	2	3	4	5	6	7
1	Model						
2	Cam ring						
3	Shaft type						
4	Shaft rotation (viewed from shaft end)	R: Clockwise	L: Counter-clockwise				
5	Porting combination	00=normal					
6	Design letter						
7	Seal class	1=S1 (for mineral oil)	4=S4 (for fire resistant fluids)	5=S5 (for mineral oil and fire resistant fluids)			
	WEIGHT	KT6C: 15.7kg	KT6D: 24kg	KT6E: 43.3kg			

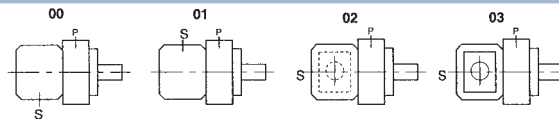

P=Pressure port
S=Suction port

Specifications

Model	Series	Displacement (cc/rev)	Delivery (lpm) At 1500rpm			Input Power (kw) At 1500rpm			Running Speed (rpm)		MAX. Pressure (bar)
			p=0 bar	p=140 bar	p=240 bar	p=7 bar	p=140 bar	p=240 bar	Max.	Min.	
KT6C	003	10.8	16.2	11.2	7.7	1.3	5.3	8.4	2800	600	300
	005	17.2	27.0	21.0	18.0	1.4	7.5	12.2			
	006	21.3	31.9	26.9	23.4	1.5	8.9	14.7			
	008	26.4	39.6	34.6	31.1	1.6	10.7	17.7			
	010	34.1	51.1	46.1	42.6	1.7	13.4	22.3			
	012	37.1	55.6	50.6	47.1	1.7	14.4	24.1			
	014	46.0	69.0	64.0	60.5	1.9	17.6	29.5			
	017	58.3	87.4	82.4	78.9	2.1	21.9	36.9			
	020	63.8	95.7	90.7	87.2	2.2	23.82	40.2			
	022	70.3	105.4	100.4	96.9	2.3	26.1	44.1			
	025	79.3	118.9	113.9	110.4	2.5	29.2	49.5			
	028	88.8	133.2	128.2	125.8	2.8	32.7	48.5	2500	230	
031	100.0	150.0	145.0	142.6	2.8	36.5	54.4				

Port connection can be furnished with metric threads, normally UNC.

DOUBLE LIPS AND PISTON TYPE SINGLE VANE PUMP

Specifications

Model	Series	Displacement (cc/rev)	Delivery (lpm) At 1500 rpm			Input Power (kw) At 1500 rpm			Runing Speed (rpm)		Max. Pressure (bar)
			p=0 bar	p=140 bar	p=240 bar	p=7 bar	p=140 bar	p=240bar	Max.	Min.	
KT6D	014	47.6	71.4	62.1	55.9	2.3	18.5	30.6	2500	600	280
	017	58.2	87.3	78.0	71.8	2.5	22.2	37.0			
	020	66.0	99.0	89.7	83.5	2.8	24.9	41.7			
	024	79.5	119.3	110.0	103.8	3.0	29.6	49.8			
	028	89.7	134.5	125.2	119.0	3.2	33.2	55.9			
	031	98.3	147.4	138.1	131.9	3.3	36.2	61.0			
	035	111.0	166.5	157.2	151.0	3.5	40.7	68.7			
	038	120.3	180.4	171.1	164.9	3.7	43.9	74.3			
	042	136.0	204.0	194.7	188.5	4.0	49.4	83.7	2200	600	280
	045	145.7	218.2	209.2	203.0	4.1	52.8	89.5			
	050	158.0	237.0	227.7	224.0	4.4	57.0	85.0			
	061	190.5	285.7	278	-	4.6	60.6	-			140

Port connection can be furnished with metric threads, normally UNC.

Model	Series	Displacement (cc/rev)	Delivery (lpm) At 1500rpm			Input Power (kw)			Runing Speed (rpm)		Max. Pressure (bar)
			p=0 bar	p=140 bar	p=240 bar	p=7 bar	p=140 bar	p=240 bar	Max.	Min.	
KT6E	042	132.3	198.5	188.5	181.3	5.2	49.4	82.6	2300	600	280
	045	142.4	213.6	203.6	196.5	5.4	52.9	88.7			
	050	158.5	237.7	227.7	220.6	5.7	58.5	98.3			
	052	164.8	247.2	237.2	230.1	5.8	60.8	102.1			
	057	180.7	271.1	261.1	254	6.1	66.4	106.9			
	062	196.7	295.0	285.0	277.9	6.4	71.9	121.3			
	066	213.3	319.9	309.9	302.8	6.7	77.7	131.2			
	072	227.1	340.6	330.6	323.5	6.9	82.6	139.5			
		085	269.8	404.7	397.7	-	7.3	97.4	-	2000	

Port connection can be furnished with metric threads, normally UNC.

DOUBLE LIPS AND PISTON TYPE SINGLE VANE PUMP

Dimensions

KT6C

Unit:mm

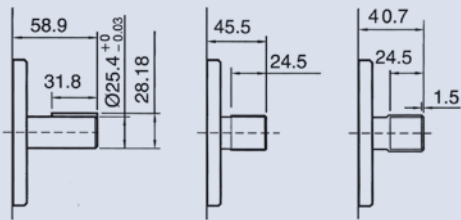
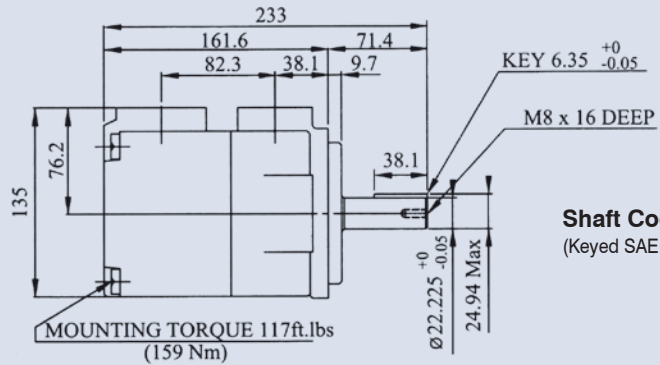
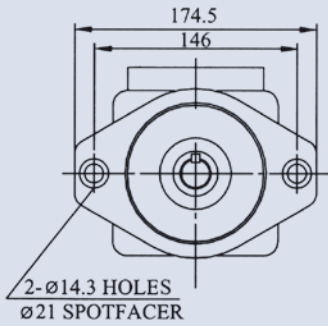

Shaft Code 5

Shaft Code 4

Shaft Code 3

SAE BB splined shaft
Class 1-J498 16/32 d.p.
-15 teeth 30° pressure
angle flat root side fit.

SAE B splined shaft
Class 1-J498 b 16/32 d.p.
-13 teeth 30° pressure
angle flat root side fit.

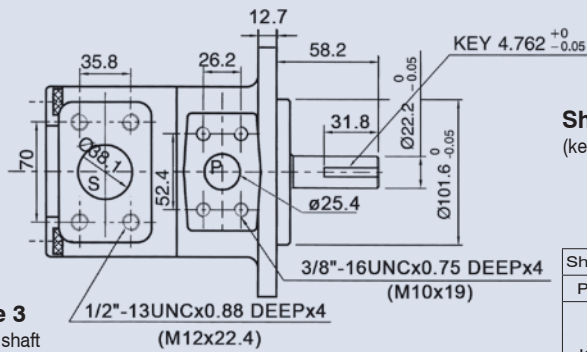

Shaft torque limits (cc/rev*bar)		
Pump	Shaft	Vp x P max.
KT6C	1	16500
	2	14300
	3	20600
	4	20600

Performance curves

KT6C Power loss hydromechanics (typical)

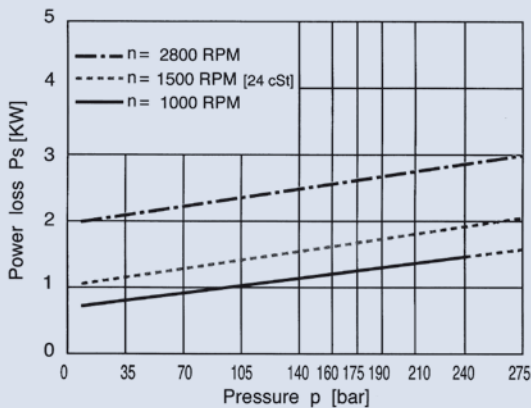

KT6C Permissible radial load

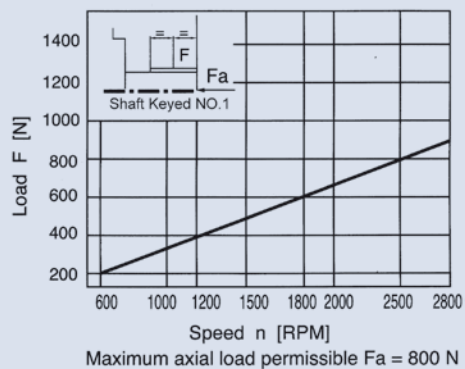

DOUBLE LIPS AND PISTON TYPE SINGLE VANE PUMP

Dimensions

KT6D

Unit:mm

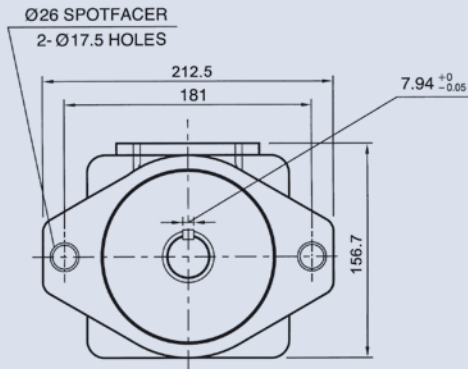

Shaft Code 1 (Keyed SAE C)

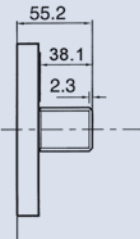
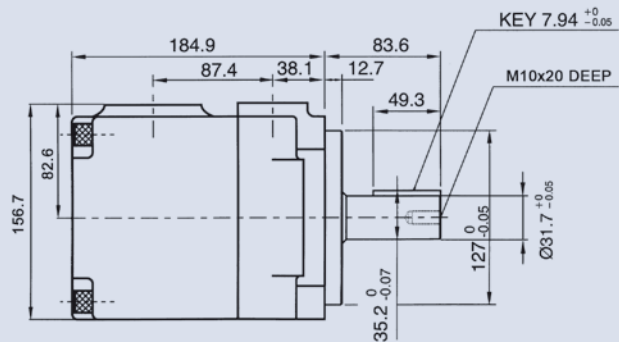

Shaft Code 3

SAE splined shaft Class 1-J498 b 12/24 d.p. -14 teeth 30° pressure angle flat root side fit.

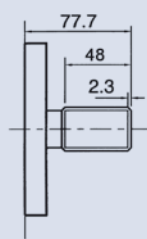

Shaft Code 4

NO SAE splined shaft Class 1-J498 b 12/24 d.p. -14 teeth 30° pressure angle flat root side fit.

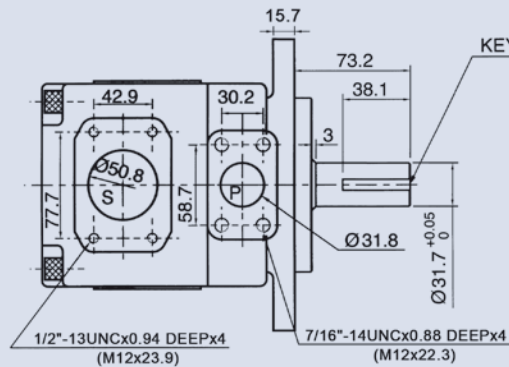

Shaft Code 2 (Keyed no SAE)

Shaft torque limits (cc/rev*bar)		
Pump	Shaft	Vp x P max.
KT6D	1	43283
	2	34590
	3	61200
	4	61200

Performance curves

KT6D Power loss hydromechanics (typical)

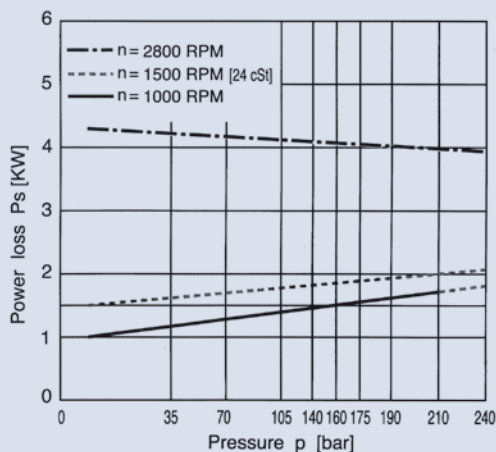

KT6D Permissible radial load

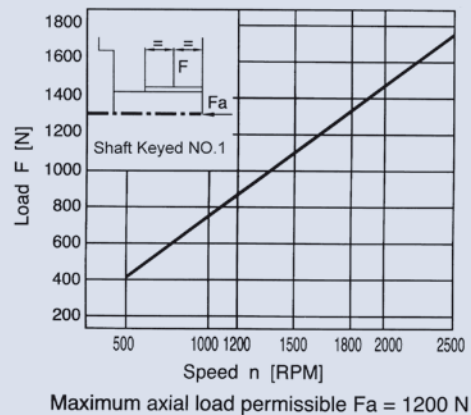

DOUBLE LIPS AND PISTON TYPE SINGLE VANE PUMP

Dimensions

KT6E

Shaft Code 1 (Keyed SAE C-C)

Unit:mm

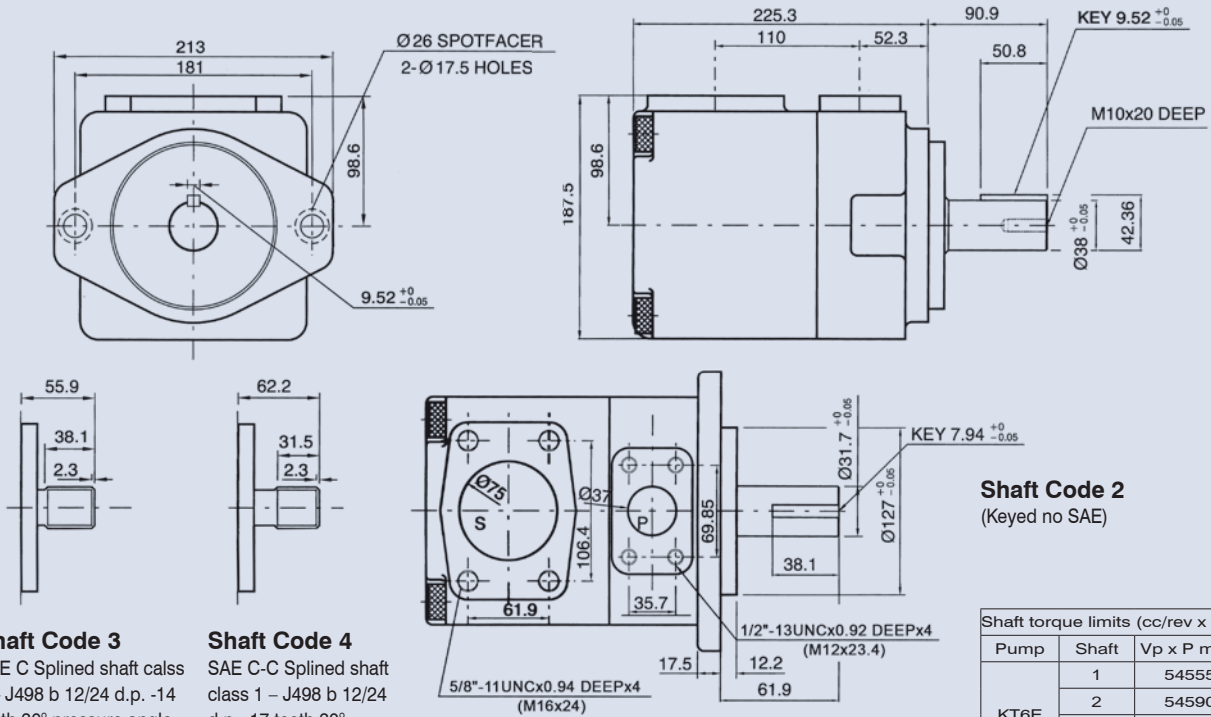

Shaft Code 3

SAE C Splined shaft class 1 - J498 b 12/24 d.p. -14 teeth 30° pressure angle flat root side fit.

Shaft Code 4

SAE C-C Splined shaft class 1 - J498 b 12/24 d.p. -17 teeth 30° pressure angle flat root side fit.

Shaft Code 2 (Keyed no SAE)

Shaft torque limits (cc/rev x bar)		
Pump	Shaft	Vp x P max.
KT6E	1	54555
	2	54590
	3	61200
	4	61200

Performance curves

KT6E Power loss hydromechanics (typical)

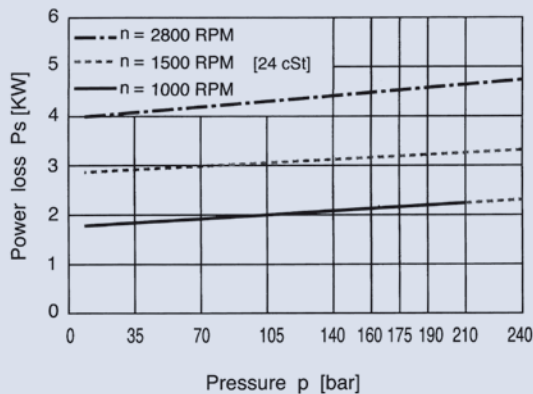

KT6E Permissible radial load

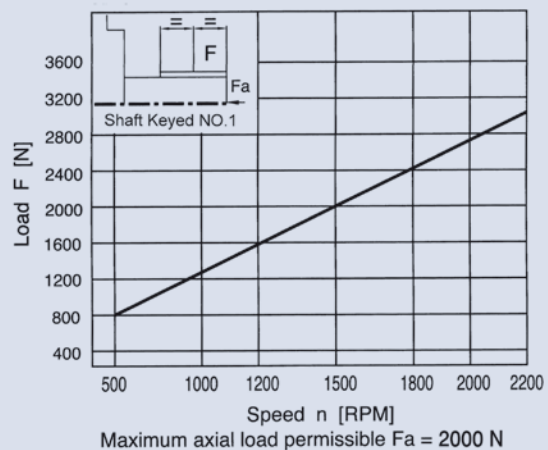

DOUBLE LIPS AND PISTON TYPE SINGLE VANE PUMP

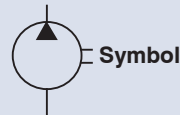

How to order

KT6DS - 014 - 1 R 00 - B 1

1 2 3 4 5 6 7

1	Model
2	Cam ring
3	Shaft type
4	Shaft rotation (viewed from shaft end) R: Clockwise L: Counter-clockwise
5	Porting combination 00: Normal
6	Design Letter
7	Seal class 1: S1 (for mineral oil) 4: S4 (for fire resistant fluids) 5: S5 (for mineral oil and fire resistant fluids)

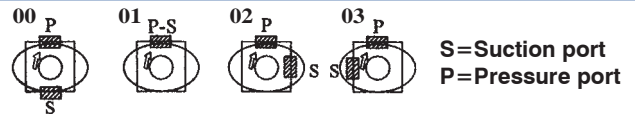

Specifications

Model	Series	Displacement (cc/rev)	Delivery (lpm) At 1500 rpm			Input Power (kw) At 1500 rpm			Max. Pressure (bar)	Runing Speed (rpm)		Weight (kg)
			p=0 bar	p=140 bar	p=240 bar	p=7 bar	p=140 bar	p=240 bar		Max.	Min.	
KT6DS	014	47.6	71.4	62.1	55.9	2.3	18.5	30.6	280	2800	600	29
	017	58.2	87.3	78.0	71.8	2.5	22.2	37				
	020	66.0	99.0	89.7	83.5	2.8	24.9	41.7				
	024	79.5	119.3	110.0	103.8	3.0	29.6	49.8				
	028	89.7	134.5	125.2	119.0	3.2	33.2	55.9				
	031	98.3	147.5	138.1	131.9	3.3	36.2	61.0				
	035	111.0	166.5	157.2	151.0	3.5	40.7	68.7				
	038	120.3	180.4	171.1	164.9	3.7	43.9	74.3				
	042	136.0	204.0	194.7	188.5	4.0	49.4	83.7				
	045	145.7	218.2	209.2	203.0	4.1	52.8	89.5				
	050	158.0	237.0	227.7	224.0	4.4	57	85.0				
061	190.5	285.7	278	-	4.6	60.6	-	230	2500			
								140				

Port connection can be furnished with metric threads, normally UNC.

Dimensions

KT6DS

Unit:mm

Shaft Code 1

(Keyed SAE C)

Shaft Code 2

(Keyed no SAE)

Shaft Code 3

SAE C Splined shaft class 1 - J498 b 12/24 d.p. -14 teeth 30° pressure angle flat root side fit.

Shaft Code 4

NO SAE Splined shaft class 1 - J498 b 12/24 d.p. -14 teeth 30° pressure angle flat root side fit.

Shaft torque limits (cc/rev x bar)		
Pump	Shaft	Vp x P max.
KT6DS	1	43283
	2	34590
	3	61200
	4	61200

DOUBLE LIPS AND PISTON TYPE SINGLE VANE PUMP

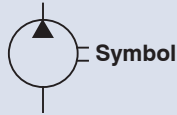

How to order

KT6GC - 022 - 6 R 00 - A 1 - 00 ✱

1	Model
2	Cam ring
3	Shaft type 6: splined (DIN 5462)
4	Shaft rotation (viewed from shaft end) R: Clockwise L: Counter-clockwise
5	Porting combination 00: Normal
6	Design Letter
7	Seal class 1: S1 (for mineral oil)
8	Port size 00: Flange 1" BSPP 01: Flange 1" SAE 4 bolts (UNC) M1: Flange 1" SAE 4 bolts (METRIC)
9	Modifications

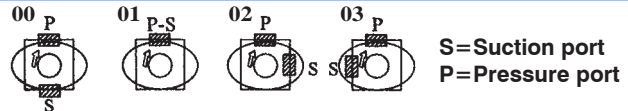

Specifications

Model	Series	Displacement (cc/rev)	Delivery (lpm) At 1500 rpm			Input Power (kw) At 1500 rpm			Max. Pressure (bar)	Running Speed (rpm)		Weight (kg)
			p=0 bar	p=140 bar	p=240 bar	p=7 bar	p=140 bar	p=240 bar		Max.	Min.	
KT6GC	003	10.8	16.2	10.7		1.3	5.3	300	3000	600	17	
	005	17.2	25.8	20.3	15.8	1.4	7.5					
	006	21.3	31.9	26.5	22.0	1.5	8.9					
	008	26.4	39.6	34.1	29.6	1.6	10.7					
	010	34.1	51.1	45.7	41.2	1.7	13.4					
	012	37.1	55.6	50.2	45.7	1.7	14.4					
	014	46.0	69.0	63.5	59.0	1.9	17.6					
	017	58.3	87.4	82.0	77.5	2.1	21.9					
	020	63.8	95.7	90.2	85.7	2.2	23.8					
	022	70.3	105.4	100.0	95.5	2.3	26.1					
	025	79.3	118.9	113.5	109.0	2.5	29.2					
	028	88.8	133.2	127.7	124.5	2.8	32.7					
031	100.0	150.0	144.5	141.3	2.8	36.5	250	2800	400			

Not to use because internal leakage greater than 50% theoretical flow.

Dimensions

KT6GC Unit:mm

Shaft Code 6
(DIN 5462) B8x32x36

MOUNTING TORQUE 117ft.lbs (159Nm)
DRAIN HOLE BETWEEN TWO SHAFT SEALS

CODE 00

1/2-13 UNCx0.9 DEEP-4 HOLES (M12x22.4)
3/8-16 UNCx0.75 DEEP-4 HOLES (M10x19)

25.4BSPP

DOUBLE LIPS AND PISTON TYPE SINGLE VANE PUMP

Dimensions

Unit:mm

KT7BS

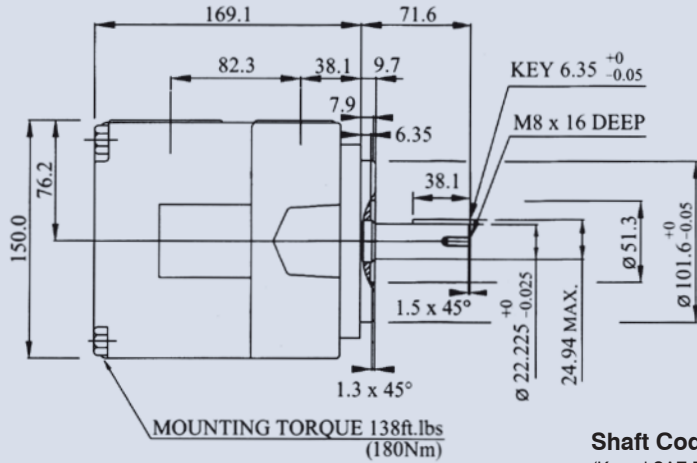
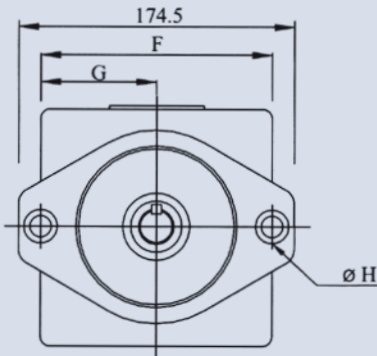

KT7B

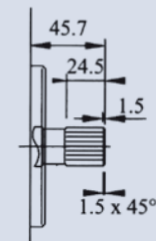
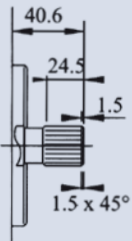

Shaft Code 3
SAE B Splined shaft class 1 - J498 b 16/32 d.p. -13 teeth 30° pressure angle flat root side fit.

Shaft Code 4
SAE BB Splined shaft class 1 - J498 b 16/32 d.p. -15 teeth 30° pressure angle flat root side fit.

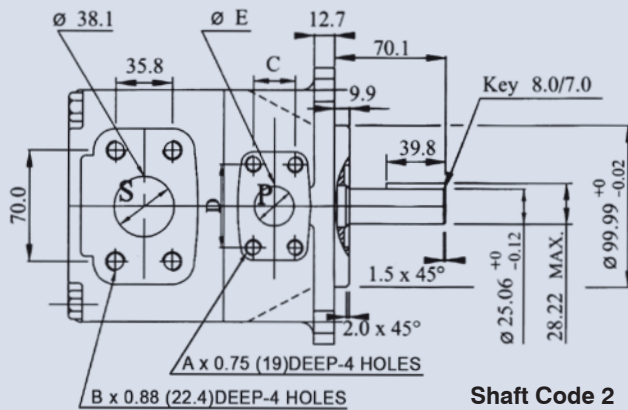

Shaft Code 1
(Keyed SAE B)

Shaft Code 2
(Keyed ISO R775)

	KT7BS		KT7B	
	00	01	M0	M1
A	3/8-16 UNC		M10	
B	1/2-13 UNC		M12	
C	1.03 (26.2)	0.874 (22.2)	1.03 (26.2)	0.874 (22.2)
D	2.06 (52.4)	1.874 (47.6)	2.06 (52.4)	1.874 (47.6)
øE	1.00 (25.4)	0.75 (19.05)	1.00 (25.4)	0.75 (19.05)
F	5.75 (146.0)		5.51 (140.0)	
G	2.87 (73.0)		2.75 (70.0)	
øH	0.56 (14.3)		0.55 (14.0)	

Shaft torque limits (cc/rev x bar)		
Pump	Shaft	Vp x P max.
KT7B	1	16516
	2	20620
	3	20620
	4	20620

DOUBLE LIPS AND PISTON TYPE DOUBLE VANE PUMP

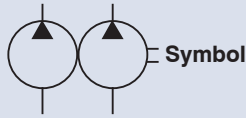

How to order

KT6CC - W - 002 - 008 - 1 R 00 C - 1 00
 1 2 P1 P2 4 5 6 7 8 9
 3

1 Model KT6CC (KT6C+6C) KT6DC (KT6D+6C) KT6EC (KT6E+6C) KT6ED (KT6E+6D)

2 W: Use for severe duty shaft only KT6CC-W: Code 2, S KT6DC-W: Code 5

3 Cam ring for P1 & P2

4 Shaft type

5 Shaft rotation (viewed from shaft end) R: Clockwise L: Counter-clockwise

6 Porting combination 00: Normal

7 Design letter

8 Seal class 1: S1 (for mineral oil) 4: S4 (for fire resistant fluids) 5: S5 (for mineral oil and fire resistant fluids)

Weight KT6CC: 26kg KT6DC: 36.6kg KT6EC: 55kg KT6ED: 66kg

9 Mounting W/connection variables

KT6CC	P1=1", S=3"		P1=1", S=2 1/2" ²⁾	
	P2	1" 3/4" ¹⁾	1" 3/4" ¹⁾	1" 3/4" ¹⁾
Code	Unc 00	01	10	11
	Metric 0M	W0	1M	W1

1) for 46 cc/rev. max.
 2) for 126 cc/rev. max.

KT6DC	UNC		Metric	
	00	01	M0	M1
P2	1"	3/4"	1"	3/4"

Specifications

Model	Pressure Port	Series	Displacement (cc/rev)	Delivery (lpm) At 1500 rpm			Input Power (kw)		
				P=0 bar	P=140 bar	P=240 bar	P=7 bar	P=140 bar	P=240 bar
KT6CC	P1 & P2	003	10.8	16.2	10.7		1.3	5.3	
		005	17.2	25.8	20.8	17.3	1.4	7.5	12.2
		006	21.3	31.9	26.9	23.4	1.5	8.9	14.7
		008	26.4	39.6	34.6	31.1	1.6	10.7	17.7
		010	34.1	51.1	46.1	42.6	1.7	13.4	22.3
		012	37.1	55.6	50.6	47.1	1.7	14.4	24.1
		014	46.0	69.0	64.0	60.5	1.9	17.6	29.5
		017	58.3	87.4	82.4	78.9	2.1	21.9	36.9
		020	63.8	95.7	90.7	87.2	2.2	23.8	40.2
		022	70.3	105.4	100.4	96.9	2.3	26.1	44.1
		025*	79.3	118.9	113.9	110.4	2.5	29.2	49.5
		028*	88.8	133.2	128.2	125.8**	2.8	32.7	48.5**
031*	100.0	150.0	145.0	142.6**	2.8	36.5	54.4**		

*025-028-031=2500 R.P.M. max. **028-031=210 bar max.int. Port connection can be furnished with metric threads, normally UNC.

DOUBLE LIPS AND PISTON TYPE DOUBLE VANE PUMP

Specifications

Model	Pressure Port	Series	Displacement (cc/rev)	Delivery (lpm) At 1500 rpm			Input Power (kw)		
				P=0 bar	P=140 bar	P=240 bar	P=7 bar	P=140 bar	P=240 bar
K6DC	P1	014	47.6	71.4	62.1	55.9	2.3	18.5	30.6
		017	58.2	87.3	78.0	71.8	2.5	22.2	37.0
		020	66.0	99.0	89.7	83.5	2.8	24.9	41.7
		024	79.5	119.3	110.0	103.8	3.0	29.6	49.8
		028	89.7	134.5	125.2	119.0	3.2	33.2	55.9
		031	98.3	147.4	138.1	131.9	3.3	36.2	61.0
		035	111.0	166.5	157.2	151.0	3.5	40.7	68.7
		038	120.3	180.4	171.1	164.9	3.7	43.9	74.3
		042*	136.0	204.0	194.7	188.5	4.0	49.4	83.7
		045*	145.7	218.5	209.2	203.0	4.1	52.8	89.5
	050*	158.0	237.0	227.7	224.0*	4.4	57.0	85.0*	
	061*	190.5	285.7	278*	–	4.6	60.6*	–	
	P2	005	17.2	25.8	20.8	17.3	1.4	7.5	12.2
		006	21.3	31.9	26.9	23.4	1.5	8.9	14.7
		008	26.4	39.6	34.6	31.1	1.6	10.7	17.7
		010	34.1	51.1	46.1	42.6	1.7	13.4	22.3
		012	37.1	55.6	50.6	47.1	1.7	14.4	24.1
		014	46.0	69.0	64.0	60.5	1.9	17.6	29.5
		017	58.3	87.4	82.4	78.9	2.1	21.9	36.9
		020	63.8	95.7	90.7	87.2	2.2	23.8	40.2
022		70.3	105.4	100.4	96.9	2.3	26.1	44.1	
025		79.3	118.9	113.9	110.4	2.5	29.2	49.5	
KT6EC	P1	042	132.3	198.5	188.5	181.3	5.2	49.4	82.6
		045	142.4	213.6	203.6	196.5	5.4	52.9	88.7
		050	158.5	237.7	227.7	220.6	5.7	58.5	98.3
		052	164.8	247.2	237.2	230.1	5.8	60.8	102.1
		057	180.7	271.1	261.1	254	6.1	66.4	106.9
		062	196.7	295.0	285.0	277.9	6.4	71.9	121.3
		066	213.3	319.9	309.9	302.8	6.7	77.7	131.2
		072	227.1	340.6	330.6	323.5	6.9	82.6	139.5
		085*	269.8	404.7	397.7*	–	7.3	97.4*	–
		P2	005	17.2	25.8	20.8	17.3	1.4	7.5
	006		21.3	31.9	26.9	23.4	1.5	8.9	14.7
	008		26.4	39.6	34.6	31.1	1.8	10.7	17.7
	010		34.1	51.1	46.1	42.6	1.7	13.4	22.3
	012		37.1	55.6	50.6	47.1	1.7	14.4	24.1
	014		46.0	69.0	64.0	60.5	1.9	17.6	29.5
	017		58.3	87.4	82.4	78.9	2.1	21.9	36.9
	020		63.8	95.7	90.7	87.2	2.2	23.8	40.2
	022		70.3	105.4	100.4	96.9	2.3	26.1	44.1
	025		79.3	118.9	113.9	110.4	2.5	29.2	49.5

For K6DC *042~061=2200 rpm max. 028, 031, 050=230 bar. 061=140 bar max int.

For K6EC *085=2000 rpm max. 028, 031=230 bar. 085=120 bar max int.

Port connection can be furnished with metric threads, normally UNC.

DOUBLE LIPS AND PISTON TYPE DOUBLE VANE PUMP

Specifications

Model	Pressure Port	Series	Displacement (cc/rev)	Delivery (lpm) At 1500 rpm			Input Power (kw)		
				P=0 bar	P=140 bar	P=240 bar	P=7 bar	P=140 bar	P=240 bar
KT6ED	P1	042	132.3	198.5	188.5	181.3	5.2	49.4	82.6
		045	142.4	213.6	203.6	196.5	5.4	52.9	88.7
		050	158.5	237.7	227.7	220.6	5.7	58.5	98.3
		052	164.8	247.2	237.2	230.1	5.8	60.8	102.1
		057	180.7	271.1	261.1	254	6.1	66.4	106.9
		062	196.7	295.0	285.0	277.9	6.4	71.9	121.3
		066	213.3	319.9	309.9	302.8	6.7	77.7	131.2
		072	227.1	340.6	330.6	323.5	6.9	82.6	139.5
	P2	085	269.8	404.7	397.7	-	7.3	97.4	-
		014	47.6	71.4	62.1	55.9	2.3	18.5	30.6
		017	58.2	87.3	78	71.8	2.5	22.2	37
		020	66.0	99.0	89.7	83.5	2.8	24.9	41.7
		024	79.5	119.3	110.0	103.8	3.0	29.6	49.8
		028	89.7	134.5	125.2	119.0	3.2	33.2	55.9
		031	98.3	147.5	138.1	131.9	3.3	36.2	61.0
		035	111.0	166.5	157.2	151.0	3.5	40.7	68.7
		038	120.3	180.4	171.1	164.9	3.7	43.9	74.3
		042*	136.0	204.0	194.7	188.5	4.0	49.4	83.7
		045*	145.7	218.5	209.2	203.0	4.1	52.8	89.5
		050*	158.0	237.0	227.7	224.0*	4.4	57.0	85.0*
061*	190.5	285.7	278	-	4.6	60.6	-		

*042~061=2200 rpm max. 050=230 bar, 061=140 bar max. int. Port connection can be furnished with metric threads, normally UNC.

Permissible radial load

KT6CC

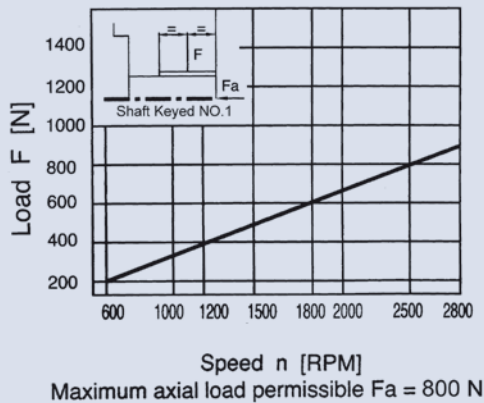

KT6EC

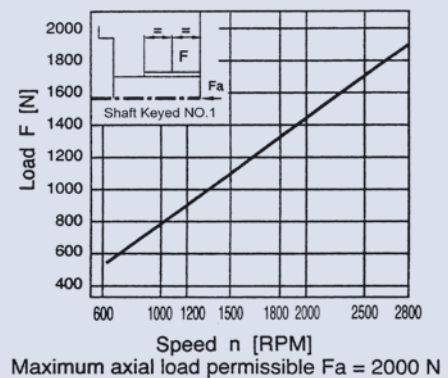

KT6DC

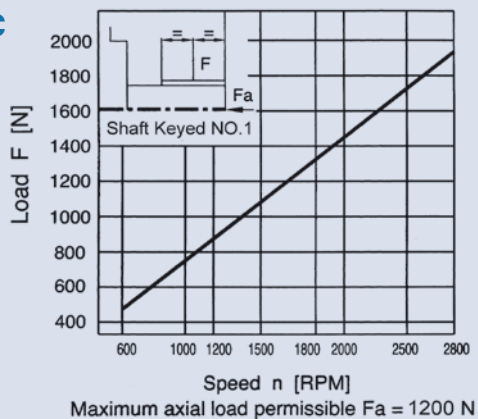

KT6ED

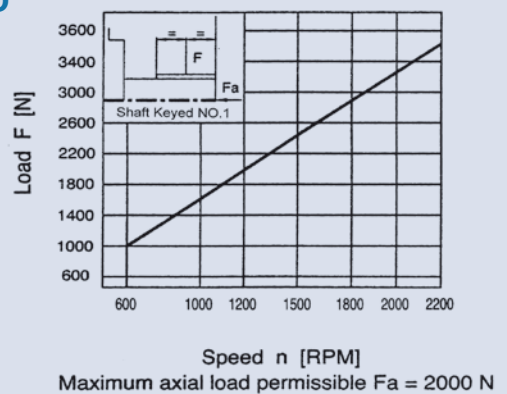

DOUBLE LIPS AND PISTON TYPE DOUBLE VANE PUMP

Dimensions

KT6CC

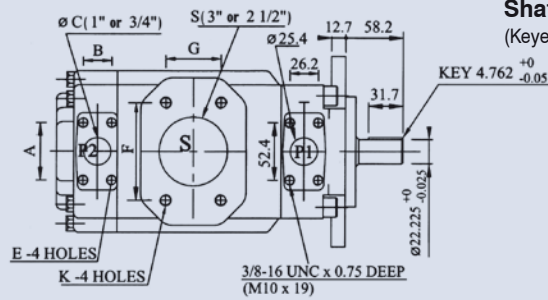
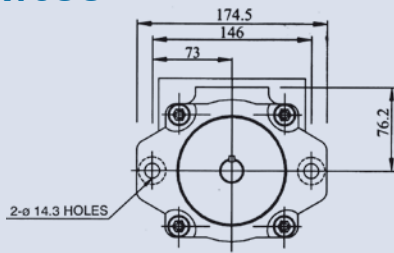

Shaft Code 1
(Keyed no SAE)

Unit:mm

Shaft Code 2
(Keyed SAE BB)

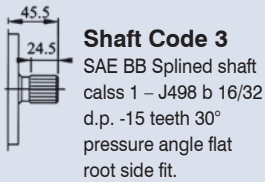

Shaft Code 3
SAE BB Splined shaft
class 1 - J498 b 16/32
d.p. -15 teeth 30°
pressure angle flat
root side fit.

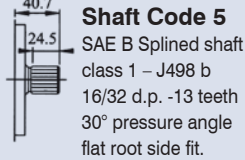

Shaft Code 5
SAE B Splined shaft
class 1 - J498 b
16/32 d.p. -13 teeth
30° pressure angle
flat root side fit.

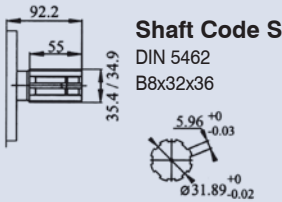

Shaft Code S
DIN 5462
B8x32x36

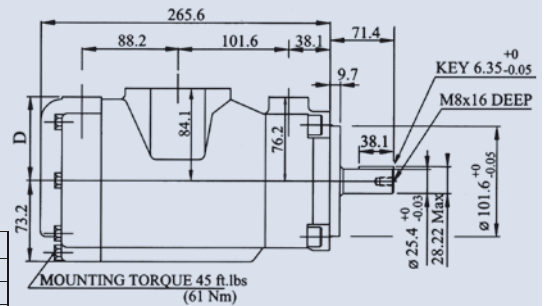

		Alternate Port							
		S = 3"				S = 2 1/2"			
F		106.4				88.9			
G		61.9				50.8			
øH		76.2				63.5			
Code		00	01	0M	W0	10	11	1M	W1
A		52.4	47.6	52.4	47.6	52.4	47.6	52.4	47.6
B		26.2	22.2	26.2	22.2	26.2	22.2	26.2	22.2
øC		25.4	19.0	25.4	19.0	25.4	19.0	25.4	19.0
D		74.7	76.2	74.7	76.2	74.7	76.2	74.7	76.2
E		3/8"-16UNCx19 deep		M10x19 deep		3/8"-16UNCx19 deep		M10x19 deep	
K		5/8"-11UNCx28.4 deep		M16x28.4 deep		1/2"-13UNCx23.9 deep		M12x24.0 deep	

Shaft torque limits (cc/rev x bar)		
Pump	Shaft	Vp x P max. P1 + P2
KT6CC	1	14300
	2	21420
	3	32670
	5	20600

KT6DC

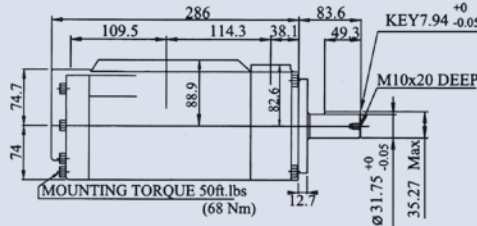
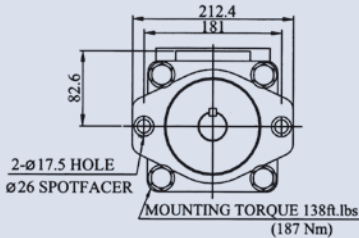

Unit:mm

Shaft Code 1
(Keyed SAE C)

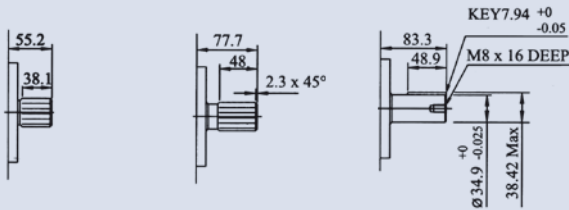

Shaft Code 3
SAE C Splined shaft
class 1 - J498 b
12/24 d.p. -14 teeth
30° pressure angle
flat root side fit.

Shaft Code 4
NO SAE Splined shaft
class 1 - J498 b 12/24
d.p. -14 teeth 30°
pressure angle flat
root side fit.

KT6DCW
Shaft codes
(Keyed no SAE)

Shaft torque limits (cc/rev x bar)		
Pump	Shaft	Vp x P max. P1 + P2
KT6DC	1	43240
	2	34590
	3	61200
	4	61200
	5	55600

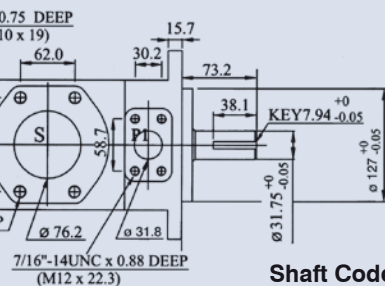

Shaft Code 2
(Keyed no SAE)

Alternate connect. variables		
	00 & Mo	01 & M1
A	1.031 (26.2)	0.874 (22.2)
B	2.06 (52.4)	1.874 (47.6)
C	1.0 (25.4)	0.75 (19.05)

DOUBLE LIPS AND PISTON TYPE DOUBLE VANE PUMP

Dimensions

KT6EC

Unit:mm

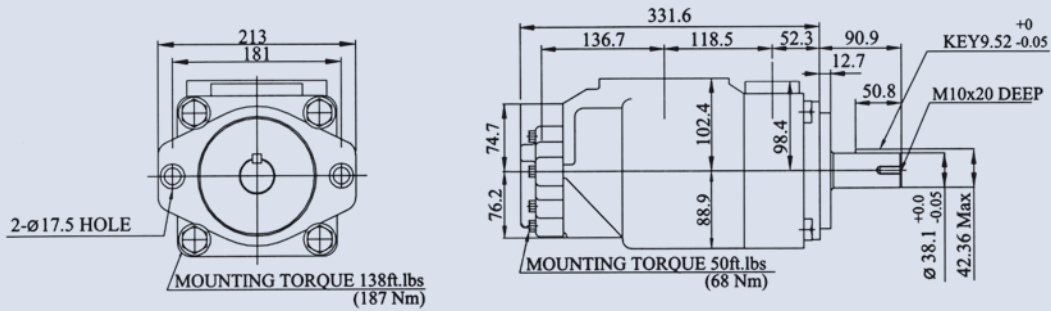

Shaft Code 1
(Keyed SAE CC)



Shaft Code 3

SAE C Splined shaft calss 1 – J498 b 12/24 d.p. -14 teeth 30° pressure angle flat root side fit.

Shaft Code 4

SAE CC Splined shaft class 1 – J498 b 12/24 d.p. -17 teeth 30° pressure angle flat root side fit.

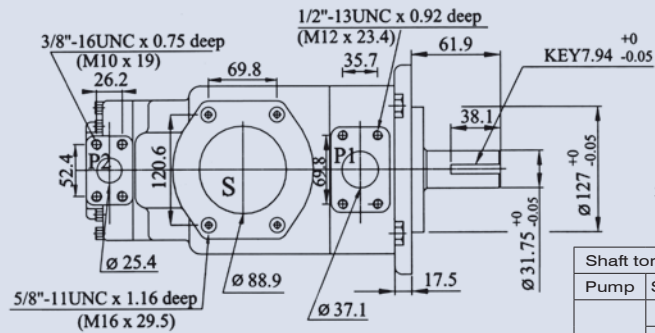

Shaft Code 2
(Keyed no SAE)

Shaft torque limits (cc/rev x bar)		
Pump	Shaft Vp x P max. P1 + P2	
KT6EC	1	72306
	2	34590
	3	61200
	4	76376

KT6ED

Unit:mm

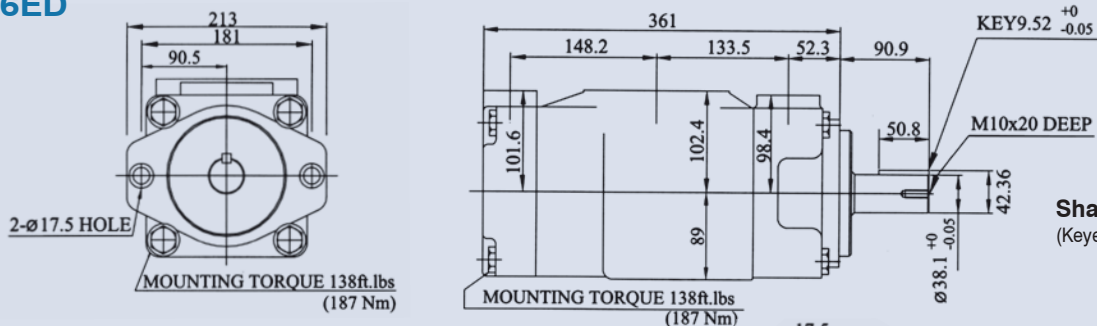

Shaft Code 1
(Keyed SAE CC)

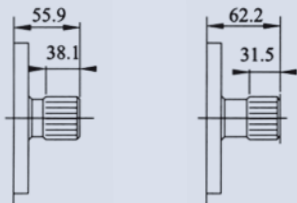

Shaft Code 3

SAE C Splined shaft calss 1 – J498 b 12/24 d.p. -14 teeth 30° pressure angle flat root side fit.

Shaft Code 4

SAE CC Splined shaft class 1 – J498 b 12/24 d.p. -17 teeth 30° pressure angle flat root side fit.

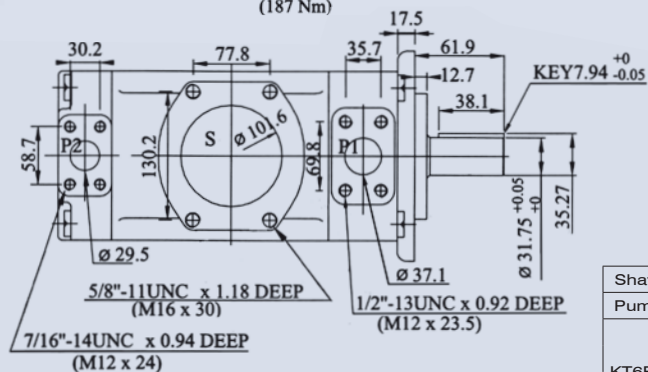

Shaft Code 2
(Keyed no SAE)

Shaft torque limits (cc/rev x bar)		
Pump	Shaft Vp x P max. P1 + P2	
KT6ED	1	72306
	2	34590
	3	61200
	4	76376

DOUBLE LIPS AND PISTON TYPE DOUBLE VANE PUMP

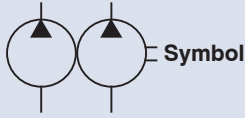

How to order

KT6GCC - 022 - 008 - 6 - R - 00 - A 1 - 00 - ✱

1 P1 P2 3 4 5 6 7 8 9

1 Model KT6GCC (KT6GC+KT6GC)
The large cartridge must be always mounted in the front.

2 Cam ring P1 & P2

3 Shaft type 6: splined (DIN 5462)

4 Shaft rotation (viewed from shaft end) R: Clockwise L: Counter-clockwise

5 Porting combination 00: Normal

6 Design letter

7 Seal class 1: S1 (for mineral oil)

8 Port size

		P1=1",S=3"		P1=1",S=2 1/2" ²⁾	
		1"	3/4" ¹⁾	1"	3/4" ¹⁾
Code	UNC	00	01	10	11
	Metric	0M	M0	1M	M1

1) for 46cc/rev.max.

2) for 126cc/rev.max.

9 Modifications weight: 28 kgs

Port combinations

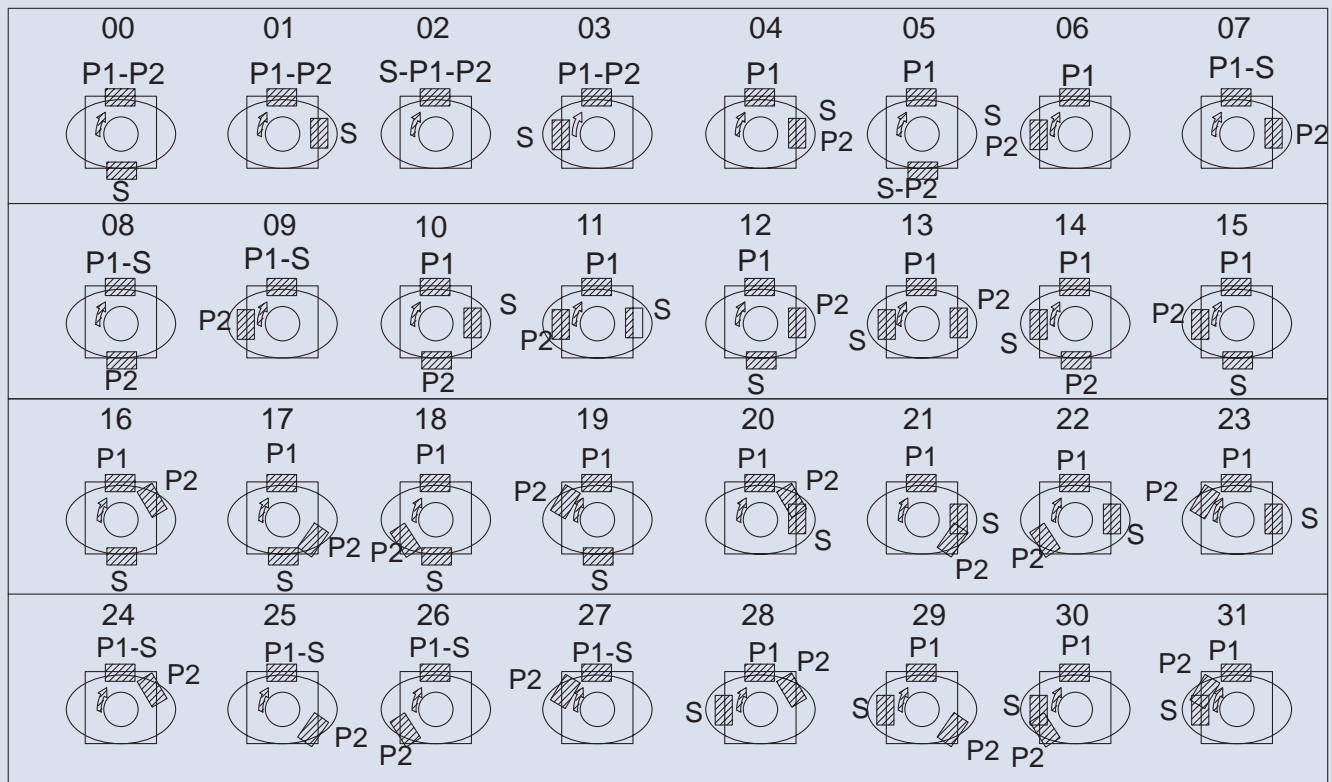

DOUBLE LIPS AND PISTON TYPE DOUBLE VANE PUMP

Specifications

Model	Pressure Port	Series	Displacement (cc/rev)	Delivery (lpm) At 1500 rpm			Input Power (kw) At 1500 rpm			Max. Pressure (bar)	Runing Speed (rpm)	
				p=0 bar	p=140 bar	p=240 bar	p=7 bar	p=140 bar	p=240 bar		Max.	Min.
KT6GCC	P1 & P2	003	10.8	16.2	10.7		1.3	5.3		300	3000	600
		005	17.2	25.8	20.3	15.8	1.4	7.5	12.2			
		006	21.3	31.9	26.5	22.0	1.5	8.9	14.7			
		008	26.4	39.6	34.1	29.6	1.6	10.7	17.7			
		010	34.1	51.1	45.7	41.2	1.7	13.4	22.3			
		012	37.1	55.6	50.2	45.7	1.7	14.4	24.1			
		014	46.0	69.0	63.5	59.0	1.9	17.6	29.5			
		017	58.3	87.4	82.0	77.5	2.1	21.9	36.9			
		020	63.8	95.7	90.2	85.7	2.2	23.8	40.2			
		022	70.3	105.4	100.0	95.5	2.3	26.1	44.1			
		025	79.3	118.9	113.5	109.0	2.5	29.2	49.5			
		028	88.8	133.2	127.7	124.5 2)	2.8	32.7	48.5			
		031	100.0	150.0	144.5	141.3 2)	2.8	36.5	54.2	230	2800	

Not to use because internal leakage greater than 50% theoretical flow.

Dimensions

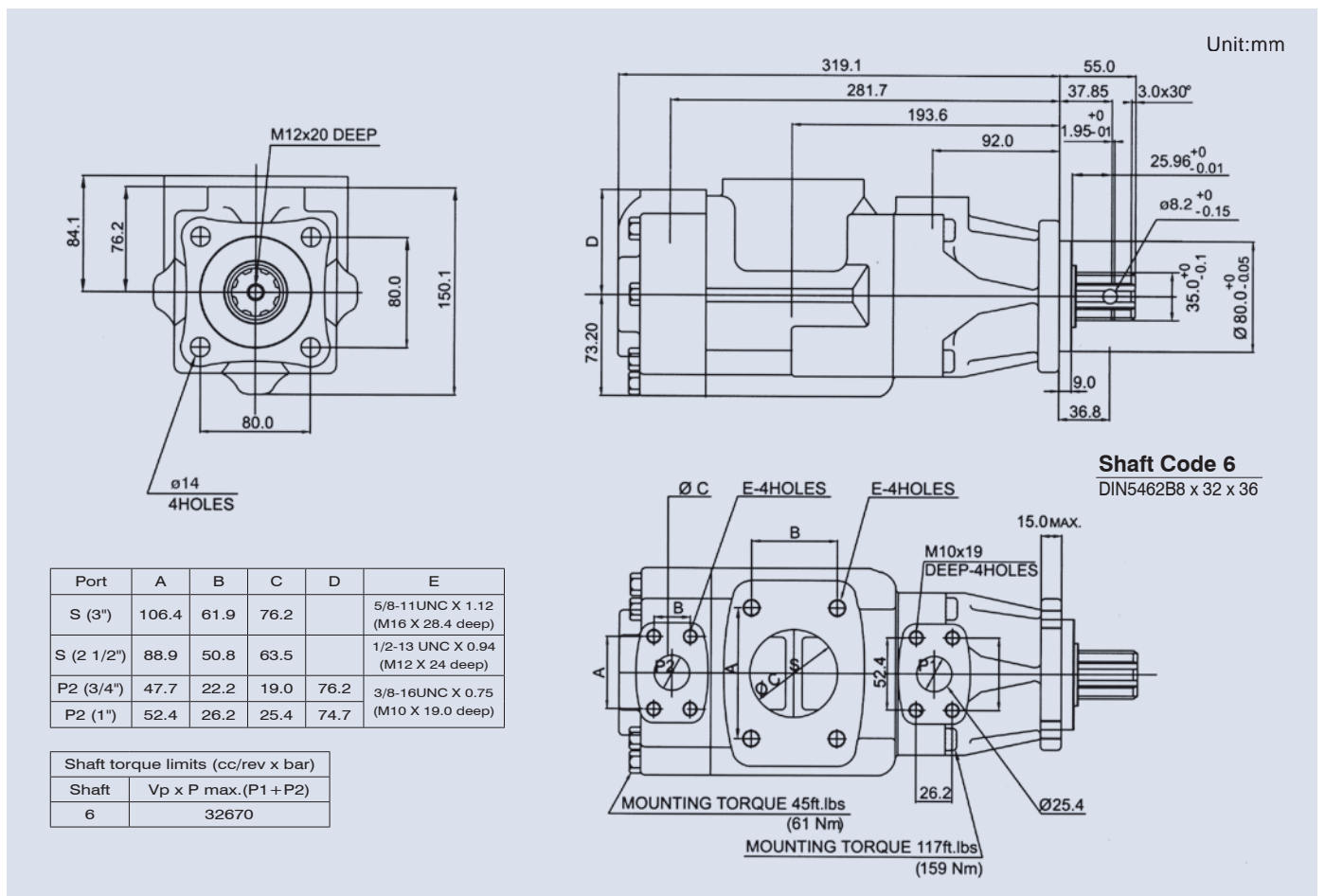

DOUBLE LIPS AND PISTON TYPE TRIPLE VANE PUMP

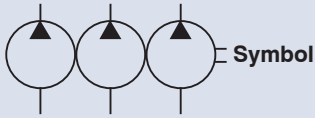

How to order

KT6DCC - 038 - 022 - 008 - 1 - R - 00 - A 1 - 00 - ✱



- 1** Model KT6DCC (KT6D+KT6C+KT6C)
- 2** Cam ring P1 P2 P3
- 3** Shaft type
- 4** Shaft rotation R: Clockwise L: Counter-clockwise
- 5** Porting combination 00: Normal
- 6** Design letter
- 7** Seal class 1: S1 (for mineral oil) 4: S4 (for fire resistant fluids) 5: S5 (for mineral oil and fire resistant fluids)
- 8** Port size

	UNC		Metric	
	00	01	M0	M1
P3	1"	3/4"	1"	3/4"

- 9** Modifications weight: 65 kgs

Port combinations

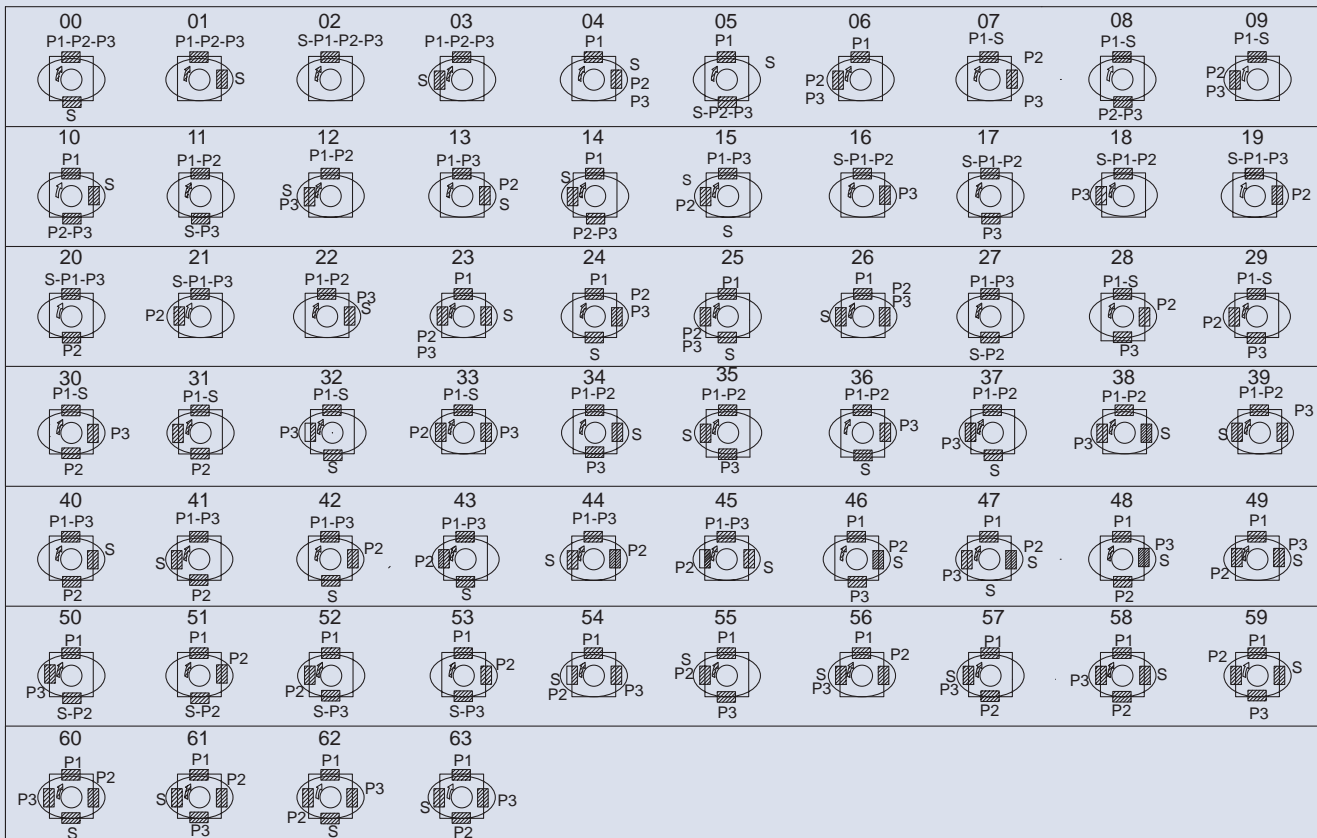

DOUBLE LIPS AND PISTON TYPE TRIPLE VANE PUMP

Specifications



Model	Pressure Port	Cam Ring	Displacement (cc/rev)	Delivery (lpm) At 1500 rpm			Input Power (kw) At 1500 rpm			Max. Pressure (bar)	Runing Speed (rpm)	
				p=0 bar	p=140 bar	p=240 bar	p=7 bar	p=140 bar	p=240 bar		Max.	Min.
KT6DCC	P1	014	47.6	71.4	62.1	55.9	2.3	18.5	30.6	300	2800	600
		017	58.2	87.3	78.0	71.8	2.5	22.2	37.0			
		020	66.0	99.0	89.7	83.5	2.8	24.9	41.7			
		024	79.5	119.3	110.0	103.8	3.0	29.6	49.8			
		028	89.7	134.5	125.2	119.0	3.2	33.2	55.9			
		031	98.3	147.5	138.1	131.9	3.3	36.2	61.0			
		035	111.0	166.5	157.2	151.0	3.5	40.7	68.7			
		038	120.3	180.4	171.1	164.9	3.7	43.9	74.3			
		042 1)	136.0	204.0	194.7	188.5	4.0	49.4	83.7			
		045 1)	145.7	218.5	209.2	203.0	4.1	52.8	89.5			
	050 1)	158.0	237.0	227.7	224.0 2)	4.4	57.0	85.0 2)				
	P2 - P3	003	10.8	16.2	10.7		1.3	5.3				
		005	17.2	25.8	20.3	15.8	1.4	7.5	12.2			
		006	21.3	31.9	26.5	22.0	1.5	8.9	14.7			
		008	26.4	39.6	34.1	29.6	1.6	10.7	17.7			
		010	34.1	51.1	45.7	41.2	1.7	13.4	22.3			
		012	37.1	55.6	50.2	45.7	1.7	14.4	24.1			
		014	46.0	69.0	63.5	59.0	1.9	17.6	29.5			
		017	58.3	87.4	82.0	77.5	2.1	21.9	36.9			
		020	63.8	95.7	90.2	85.7	2.2	23.8	40.2			
022		70.3	105.4	100.0	95.5	2.3	26.1	44.1				
025	79.3	118.9	113.5	109.0	2.5	29.2	49.5					
028	88.8	133.2	127.7	124.5 3)	2.8	32.7	48.5 3)					
031	100.0	150.0	144.5	141.3 3)	2.8	36.5	54.2 3)					

1) 042-045-050=2500 rpm max. 2) 050=230 bar max. int. 3) 028-031=230 bar max. int.

Dimensions

Unit:mm

NO.4 Shaft
SAE CC splined shaft
Class I-J498 b 12/24 d.p.
-17 teeth 30°
pressure angle flat root
side fit

NO.1 Shaft (keyed no SAE)

NO.3 Shaft
SAE C splined shaft
Class 1-J498 b
12/24 d.p.-14 teeth 30°
pressure angle
flat root side fit

NO.2 Shaft (keyed SAE CC)

Shaft torque limits (cc/rev x bar)	
Shaft	Vp x p max. (P1 + P2 + P3)
1	43240
2	66500
3	61200
4	66500

PORT	CODE	A	B	C
P3	00 & M0	52.4	26.2	25.4
	01 & M1	47.6	22.2	19.0

GEAR PUMP

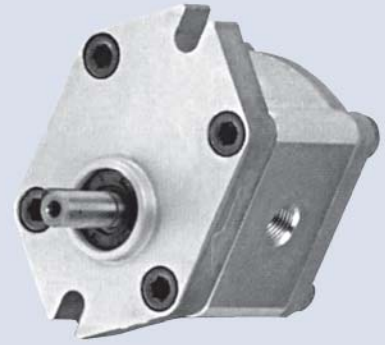
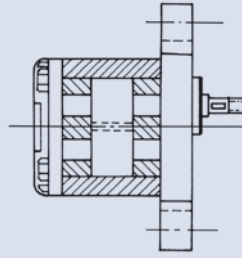
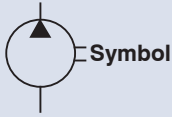

How to order

HGP - 05A - F - * - R - X

- 1 Model
- 2 Series number
- 3 Mounting type F: Flange mounting L: Foot mounting
- 4 Displacement cc/rev
- 5 Rotation R: Clockwise L: Counter-clockwise
- 6 Shaft type X: Straight shaft

Specifications

Model	Displacement (cc/rev)	Pressure bar (psi)		Runing Speed (rpm)			Port Size		Weigth (kg)
		Working	Max.	Rate	Max.	Min.	Inlet	Outlet	
HGP-05A-*03*	0.35	210 (3000)	250 (3500)	1800	3500	800	1/8"	1/8"	0.40
HGP-05A-*05*	0.56						0.42		
HGP-05A-*08*	0.85						0.43		
HGP-05A-*1.1*	1.13						0.44		

Dimensions

CW ROTATION

Dimensions: 22.5, 66, 77, 6.8, 49, 9.20, 3, 10.25, 3.8, A Max, B, 49, 3x12, $\phi 22^{+0.05}$, $\phi 8^{-0.02}$

Unit:mm

Model	Dimension A
HGP-05A-*03*	52
HGP-05A-*05*	54
HGP-05A-*08*	56
HGP-05A-*1.1*	58

Model	Dimension B
HGP-05A-*03*	25
HGP-05A-*05*	26
HGP-05A-*08*	27
HGP-05A-*1.1*	28

Performance curves

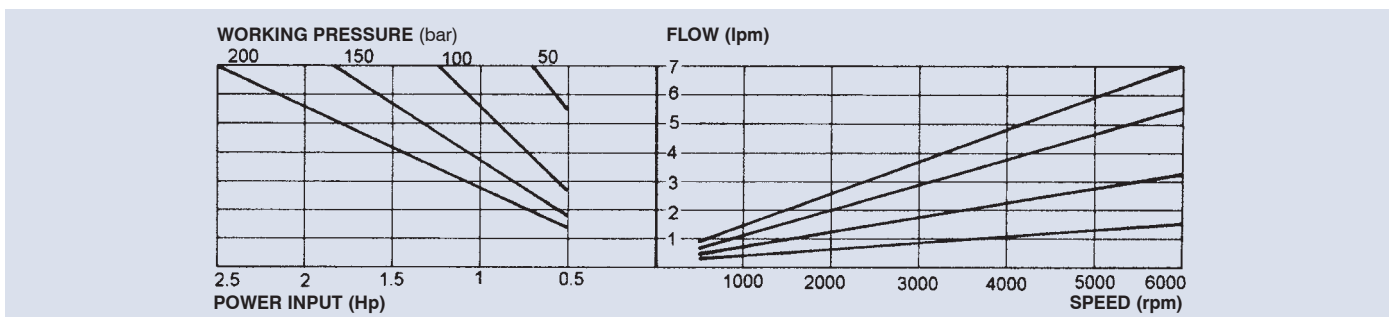

GEAR PUMP

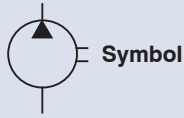

How to order

HGP - 1A - F - * - R - X - 2B

- | | | | |
|---|---------------------|---------------------|---|
| 1 | Model | HGP: Gear pump only | PR2: Gear pump with relief (see page 136) |
| 2 | Series number | | |
| 3 | Mounting type | F: Flange mounting | L: Foot mounting |
| 4 | Displacement cc/rev | | |
| 5 | Rotation | R: Clockwise | L: Counter-clockwise |
| 6 | Shaft type | X: Straight shaft | Y: Splined shaft |
| 7 | Mounting flange | 2B: SAE 2-Bolt | 4BD: Din 4-Bolt 4BE: European 4-Bolt |

Specifications

Model	Displacement (cc/rev)	Pressure bar (psi)		Runing Speed (rpm)			Weight (kg)
		Working	Max.	Rate	Max.	Min.	
HGP-1A-F1*	1	210 (3000)	250 (3500)	1800	4500	1000	1.0
HGP-1A-F2*	2				4500	600	1.05
HGP-1A-F3*	3				4500	600	1.15
HGP-1A-F4*	4				4000	600	1.18
HGP-1A-F5*	5				3200	600	1.2
HGP-1A-F6*	6				3200	600	1.3
HGP-1A-F7*	7				3200	600	1.4
HGP-1A-F8*	7.8				3200	600	1.4

Remark: HGP-1A-F05 (0.5 cc/rev), F08 (0.8 cc/rev) and F2.6 (2.6 cc/rev) are for special order.

Dimensions

HGP-1A-F-*-*-*2B(SAE 2-Bolt)

Unit:mm

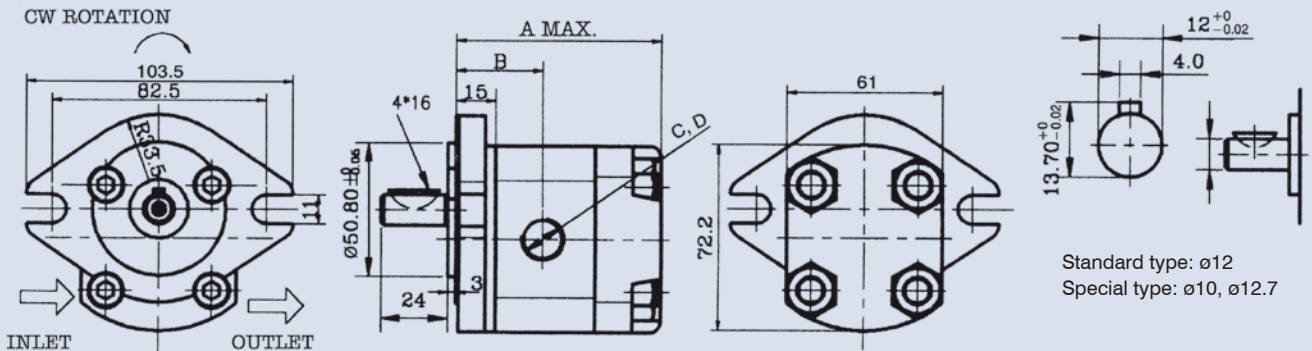

GEAR PUMP

Dimensions

HGP-1A-F-**-**-**-4BD (DIN 4-Bolt)

Unit:mm

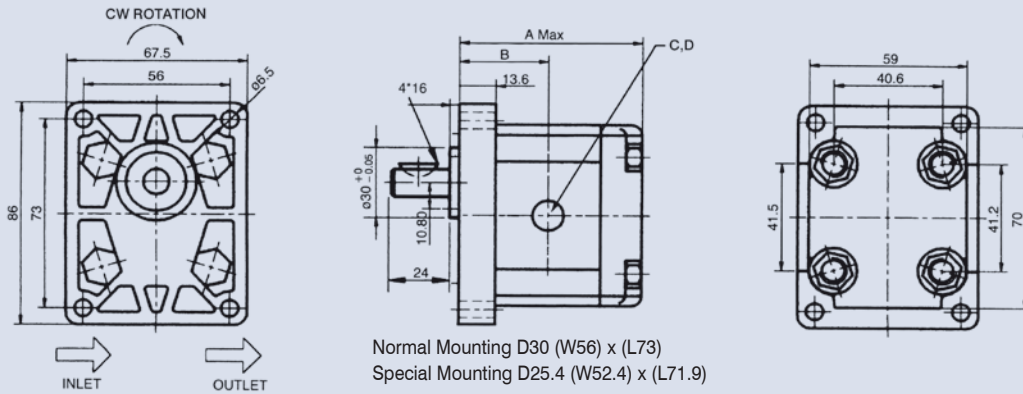

HGP-1A-F-**-**-**-4BE (European 4-Bolt)

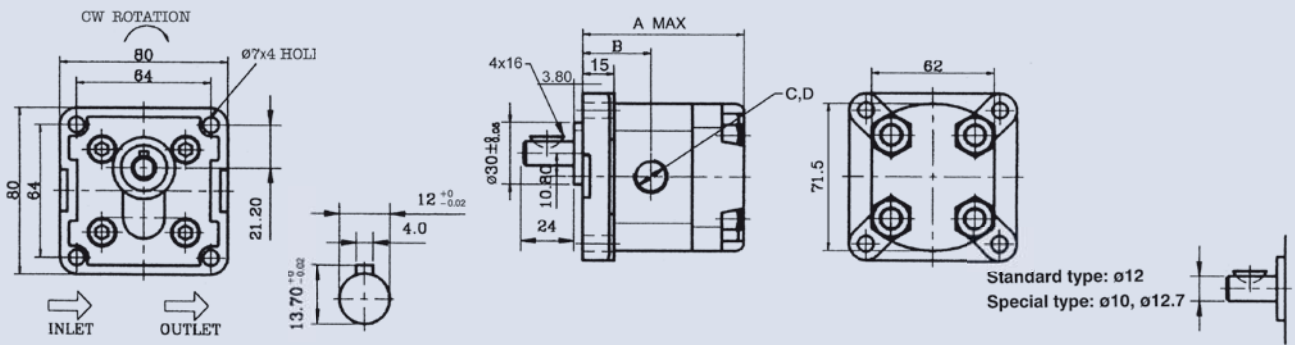

Specifications

Model	Dimension A (mm)		Dimension B (mm)	Port Size C, D	
	4BD	4BE		inlet	outlet
HGP-1A-F08*	67.5	75.5	32.5	3/8" PT	3/8" PT
HGP-1A-F1*	69.5	77.5	33.5	3/8" PT	3/8" PT
HGP-1A-F2*	72	80.1	34.8	3/8" PT	3/8" PT
HGP-1A-F3*	77.5	85.5	37.5	3/8" PT	3/8" PT
HGP-1A-F4*	79.5	87.5	38.5	3/8" PT	3/8" PT
HGP-1A-F5*	82.5	91.5	40.5	3/8" PT	3/8" PT
HGP-1A-F6*	87.5	95.5	42.5	3/8" PT	3/8" PT
HGP-1A-F8*	93.5	101.50	45.5	1/2" PT	3/8" PT

Performance curves

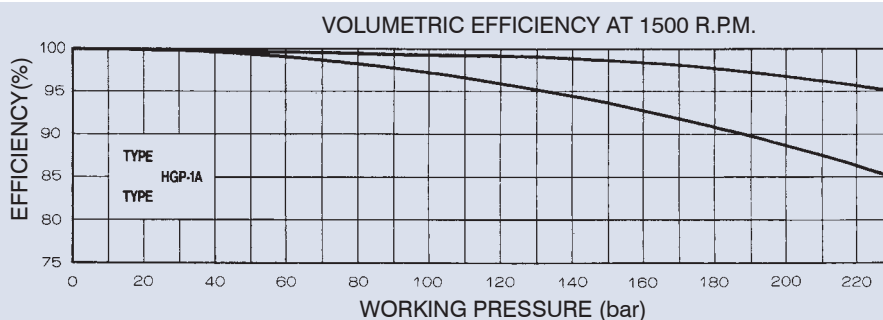

GEAR PUMP

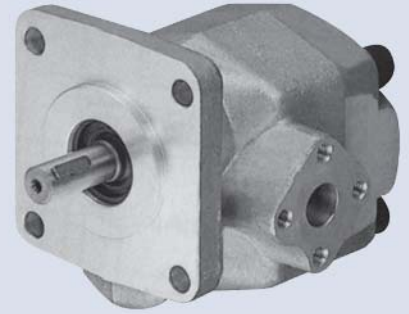
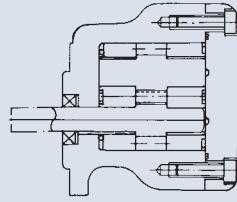
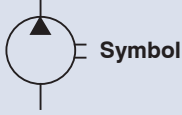

How to order

HGP - 2A - F - ※ - R - X - 4BJ

1	Model	HGP: Gear pump only	PR1: Gear pump with relief (see page 135)
2	Series number		
3	Mounting type	F: Flange type	L: Foot type
4	Displacement cc/rev		
5	Rotation	R: clockwise	L: Counter-clockwise
6	Shaft type	X: Straight shaft	Y: Splined shaft
7	Mounting flange	4BJ: JIS 4-Bolt	

Specifications

Model	Displacement (cc/rev)	pressure bar (psi)		Runing Speed (rpm)			Weight (kg)
		Working	Max.	Rate	Max.	Min.	
HGP-2A-※2※	2	210 (3000)	250 (3500)	1800	5000	900	1.69
HGP-2A-※3※	3				5000	850	1.70
HGP-2A-※4※	4				4500	800	1.71
HGP-2A-※6※	6				3500	700	1.72
HGP-2A-※8※	8				3000	600	1.74
HGP-2A-※9※	9				2500	550	1.74
HGP-2A-※11※	11				2000	500	1.74
HGP-2A-※12※	12	175 (2500)	210 (3000)	2000	550	1.76	

REMARK: HGP-2A-F2.5 (2.5 cc/rev) and F5 (5 cc/rev) are for special order.

FEATURES:

1. High-Tech aluminum alloy bushings and dry bearings are used to ensure wearing resistance and withstand extra high speed up to 5000 R.P.M.
2. The woodruff key used in this pump withstands much higher torque.
3. A special internal circuit design guarantees that the seal will not be pooped out in case of instant reverse.
4. Dual balanced plating with the bushings is designed such that pump is totally sealed for higher volume efficiency as well as durability.
5. Useful in various applications such as construction machines, Hydraulic elevator and other special purpose machinery.
6. Relief valve can be added on pump case and in connection with lifting valve for use in Hydraulic elevator.

GEAR PUMP

Dimensions

HGP-2A

Unit:mm

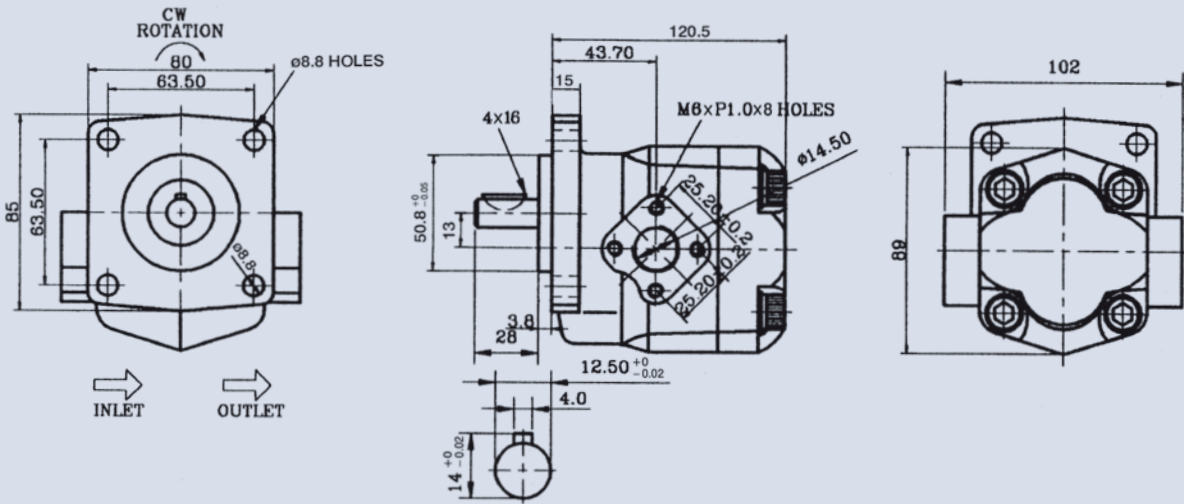

Performance curves

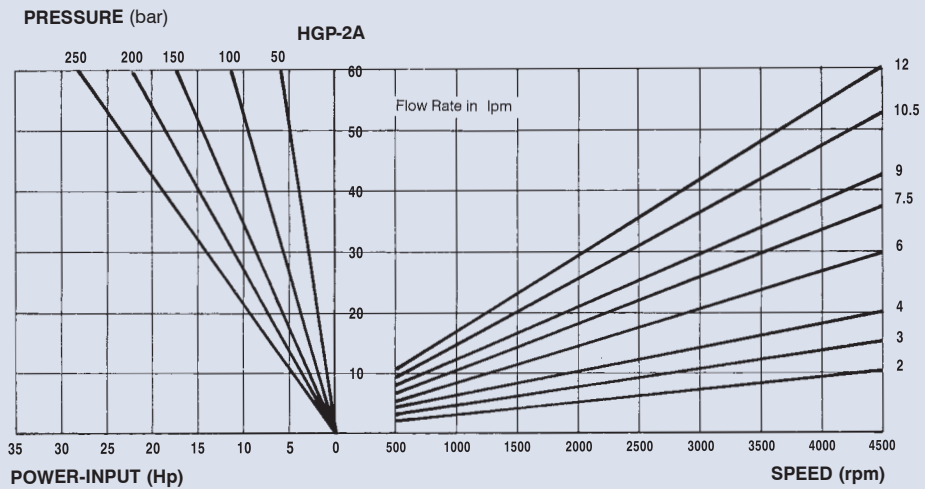

GEAR PUMP

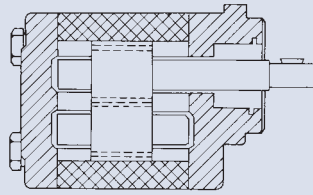
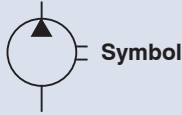

How to order

HGP - 3A - F - * - R - X - 2B

1	Model
2	Series number
3	Mounting type F: Flange type L: Foot type
4	Displacement cc/rev
5	Rotation R: Clockwise L: Counter-clockwise
6	Shaft type X: Straight shaft (Normal: DIA 15.875=2~30 cc/rev, 17.46=33~35 cc/rev) Y: Splined shaft Z: Taper shaft
7	Mounting flange 2B: SAE 2-Bolt 4BD: DIN 4-Bolt

Specifications

Model	Displacement (cc/rev)	Pressure bar (psi)		Runing Speed (rpm)			A	B	Port Size C,D		Weight (kg)
		Working	Max.	Rate	Max.	Min.			Inlet	Outlet	
HGP-3A-*2*	2	210 (3000)	250 (3500)	1800	3000	700	97.4	46.7	3/4"	1/2"	2.19
HGP-3A-*3*	3						99	47.5			2.23
HGP-3A-*4*	4						101	48.5			2.29
HGP-3A-*6*	6						105	50			2.37
HGP-3A-*8*	8.4						109	51.5			2.45
HGP-3A-*11*	11					500	113	54			2.6
HGP-3A-*13*	13						117	56			2.7
HGP-3A-*14*	14.3						119	57			2.76
HGP-3A-*17*	16.5						123	59			2.87
HGP-3A-*19*	19.2						127	61			2.99
HGP-3A-*23*	23	175 (2500)	210 (3000)	1200	2500	134	65	1"	3/4"	3.19	
HGP-3A-*25*	25					137	66			3.24	
HGP-3A-*28*	28					141	68			3.35	
HGP-3A-*30*	30					145	70			3.45	
HGP-3A-*33*	33	150 (2200)	180 (2600)	1200	2500	150	73	3.6			
HGP-3A-*35*	35	130 (1900)	150 (2200)	1200	2500	154	75	3.71			

FEATURES:

1. Dual balanced plating and dry bearings used in this pump feature excellent resistance to wearing, thrust, impact, as well as extra high speed revolution.
2. Dual balanced plating with the bushings is designed such that pump is totally sealed for higher volume efficiency as well as durability.
3. The woodruff key used in this pump withstands much higher torque.
4. A special internal circuit design guarantees that the seal will not be popped out in case of instant reverse.
5. Withstands instant pressure up to 210 bar (3000 psi) and runs up to 2000000 cycles.
6. Direction may be changed at any time.

GEAR PUMP

Dimensions

HGP-3A-F--- - 2B (SAE 2-Bolt)

Unit:mm

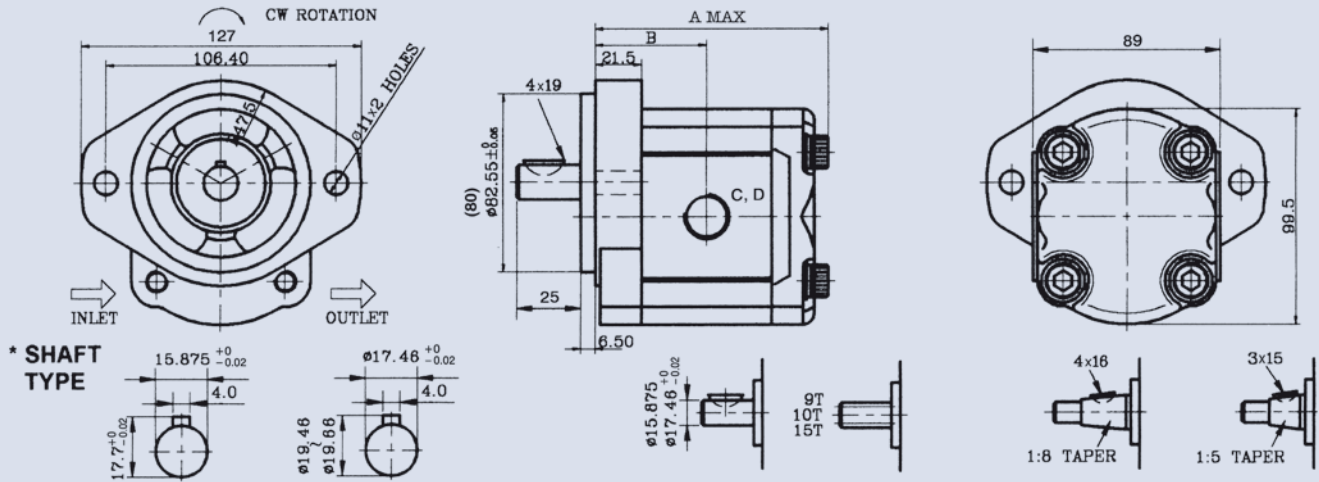

HGP-3A-F--- - 4BD (DIN 4-Bolt)

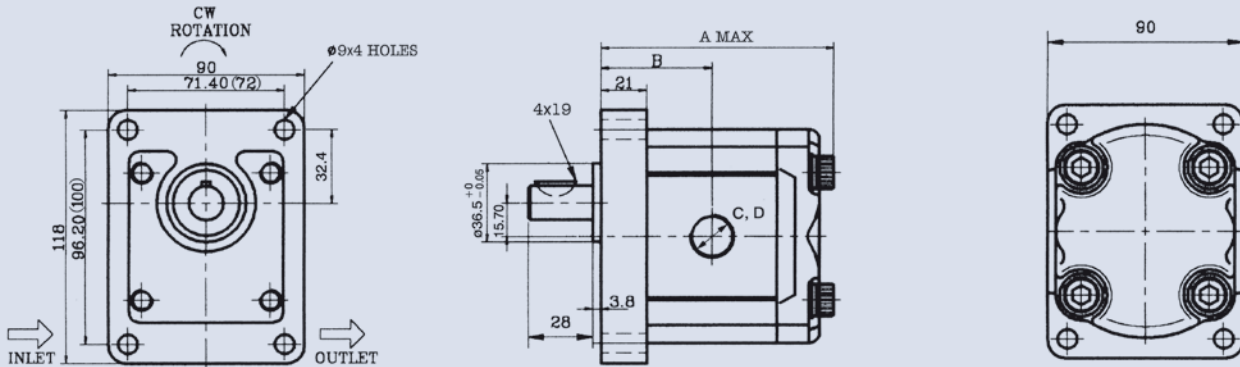

REMARK: The size in () is for special order, see page 131 for the size of A, B and port size C, D.

Performance curves

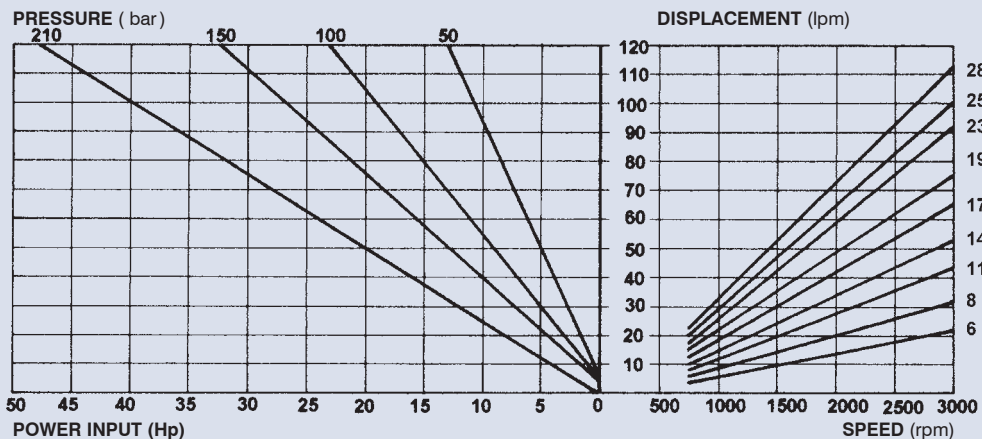

DOUBLE GEAR PUMP

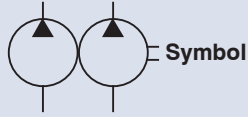

How to order

HGP - 22A - F - 32 - R - X - 4BJ

1	2	3	4	5	6	7
1	Model					
2	Series number					
3	Mounting type F: Flange type L: Foot type					
4	Displacement cc/rev 32: P1=3 cc/rev P2=2 cc/rev					
5	Rotation R: Clockwise L: Counter-clockwise					
6	Shaft type X: Straight shaft Y: Splined shaft Z: Taper shaft					
7	Mounting flange 4BJ: JIS 4-Bolt					

Specifications

(Refer to page 129)

Working pressure: 210 bar (3000 psi)

Displacement: 4 cc/rev - 24 cc/rev

Mounting flange: JIS 4-Bolt

Dimensions

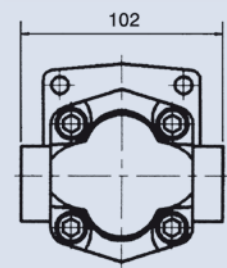
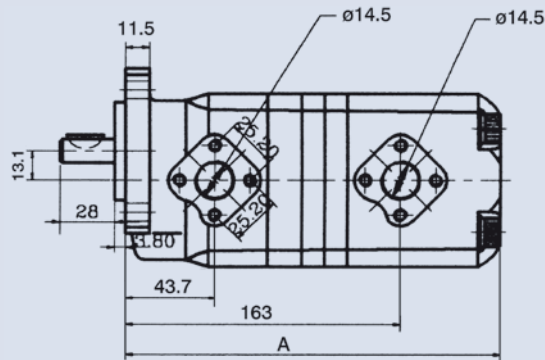
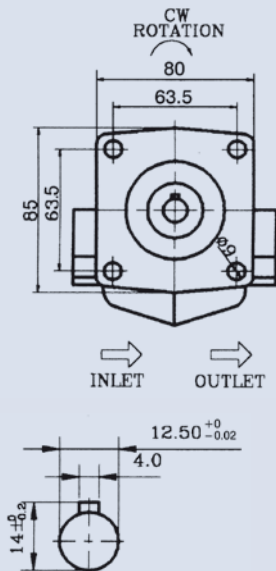

Unit:mm

Model	A mm	Model	A mm	Weight (kg)
HGP-22A-*22*	220	HGP-22A-*88*	220	4.5
HGP-22A-*33*	220	HGP-22A-*99*	220	
HGP-22A-*44*	220	HGP-22A-*1111*	220	
HGP-22A-*66*	220	HGP-22A-*1212*	220	

DOUBLE GEAR PUMP

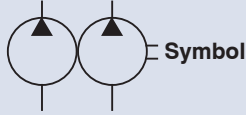

How to order

HGP - 33A - F - 32 - R - X - ☼

1	2	3	4	5	6	7
1	Model					
2	Series number					
3	Mounting type F: Flange type L: Foot type					
4	Displacement cc/rev 32: P1=3 cc/rev P2=2 cc/rev					
5	Rotation R: clockwise L: Counter-clockwise					
6	Shaft type X: Straight shaft Y: Splined shaft Z: Taper shaft					
7	Mounting flange 2B: SAE 2-Bolt 4BD: DIN 4-Bolt					

Specifications

(Refer to page 131)

Working pressure: 210 bar (3000 psi)

Displacement: 4 cc/rev - 70 cc/rev

Mounting flange: SAE 2-Bolt DIN 4-Bolt

Dimensions

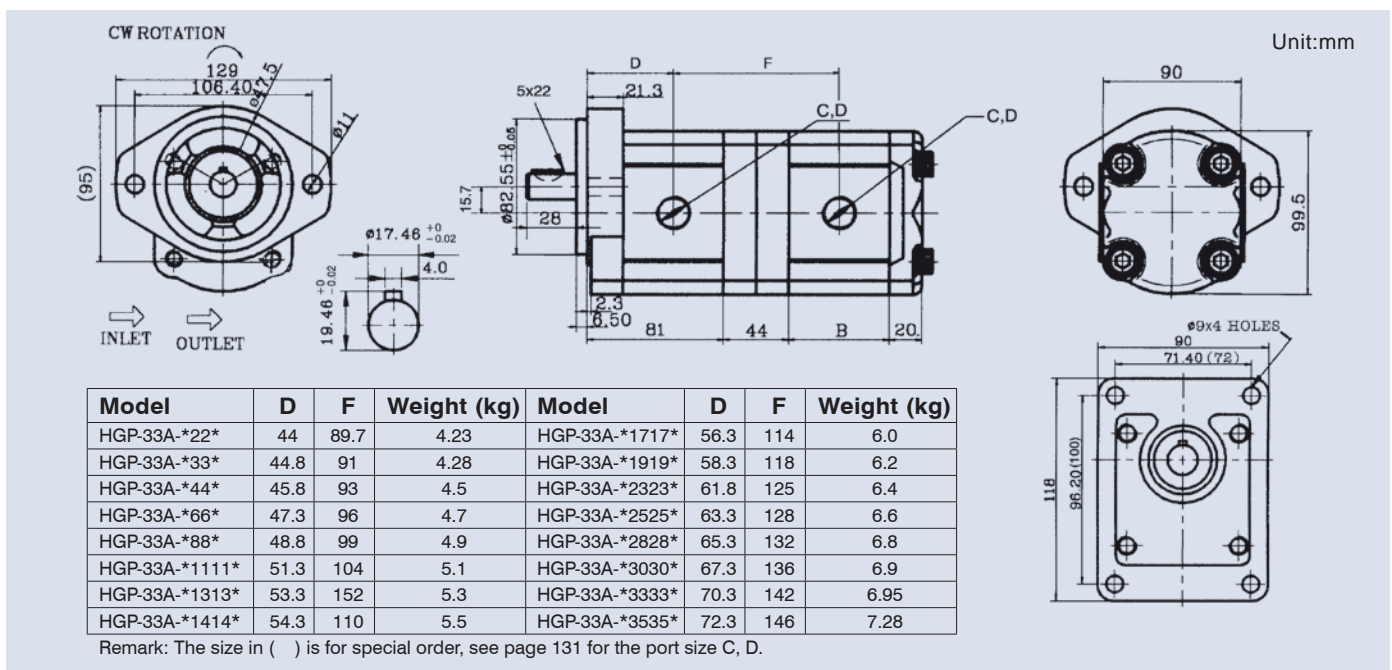

GEAR PUMP WITH RELIEF VALVE

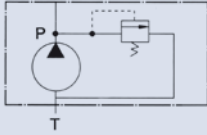

How to order

PR1 - F - ✖ - R - 4BJ

- | 1 | 2 | 3 | 4 | 5 |
|---|--|---|---|---|
| 1 | Model (Reper to page 129, 130) | | | |
| 2 | Mounting type F: Flange type L: Foot type | | | |
| 3 | Displacement cc/rev | | | |
| 4 | Rotation R: Clockwise L: Counter-clockwise | | | |
| 5 | Mounting flange 4BJ: JIS 4-Bolt | | | |

Specifications

Model	Displacement (cc/rev)	Pressure (bar) (psi)		Runing Speed (rpm)			Weight (kg)
		Working	Max.	Rate	Max.	Min.	
PR1-020	2	210 (3000)	250 (3500)	1800	5000	900	1.69
PR1-030	3				5000	850	1.7
PR1-040	4				4500	800	1.71
PR1-060	6				3500	700	1.72
PR1-075	7.5				3000	600	1.74
PR1-090	9				2500	550	1.74
PR1-105	10.5				2000	500	1.74
PR1-120	12				2000	500	1.76

REMARK: PR1-F2.5 (2.5cc/rev) and F5 (5cc/rev) are for special order.

Dimensions

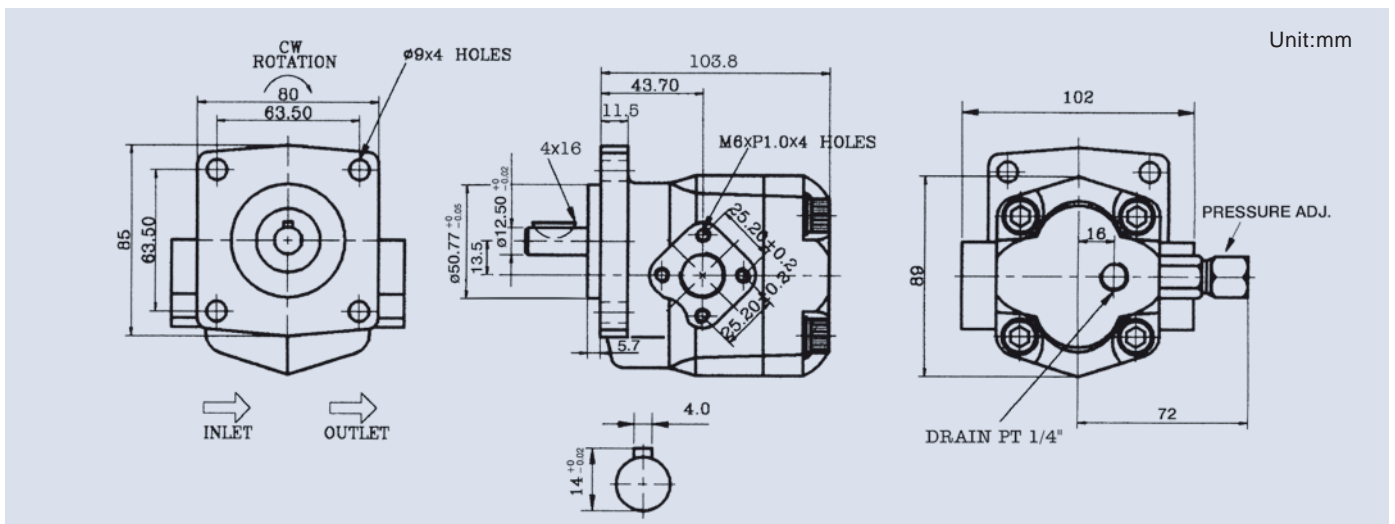

GEAR PUMP WITH RELIEF VALVE

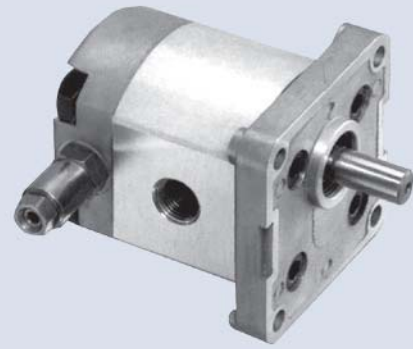
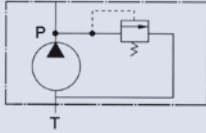

How to order

PR2 - F - ✖ - R - 4B

- | | |
|---|---|
| 1 | Model (Reper to page 127, 128) |
| 2 | Mounting type F: Flange type L: Foot type |
| 3 | Displacement cc/rev |
| 4 | Rotation R: Clockwise L: Counter-clockwise |
| 5 | Mounting flange 2B: SAE 2-Bolt 4BD: DIN 4-Bolt 4BE: European 4-Bolt |

Specifications

Model	Displacement (cc/rev)	Pressure bar (psi)		Runing Speed (rpm)			Weight (kg)
		Working	Max.	Rate	Max.	Min.	
PR2-010	1	210 (3000)	250 (3500)	1800	4500	1000	1.0
PR2-020	2				4500	600	1.05
PR2-030	3				4500	600	1.15
PR2-040	4				4000	600	1.18
PR2-050	5				3200	600	1.2
PR2-060	6				3200	600	1.3
PR2-080	7.8				3200	600	1.4

REMARK: PR2-008 (0.8 cc/rev) and PR2-026 (2.6 cc/rev) are for special order.

Dimensions

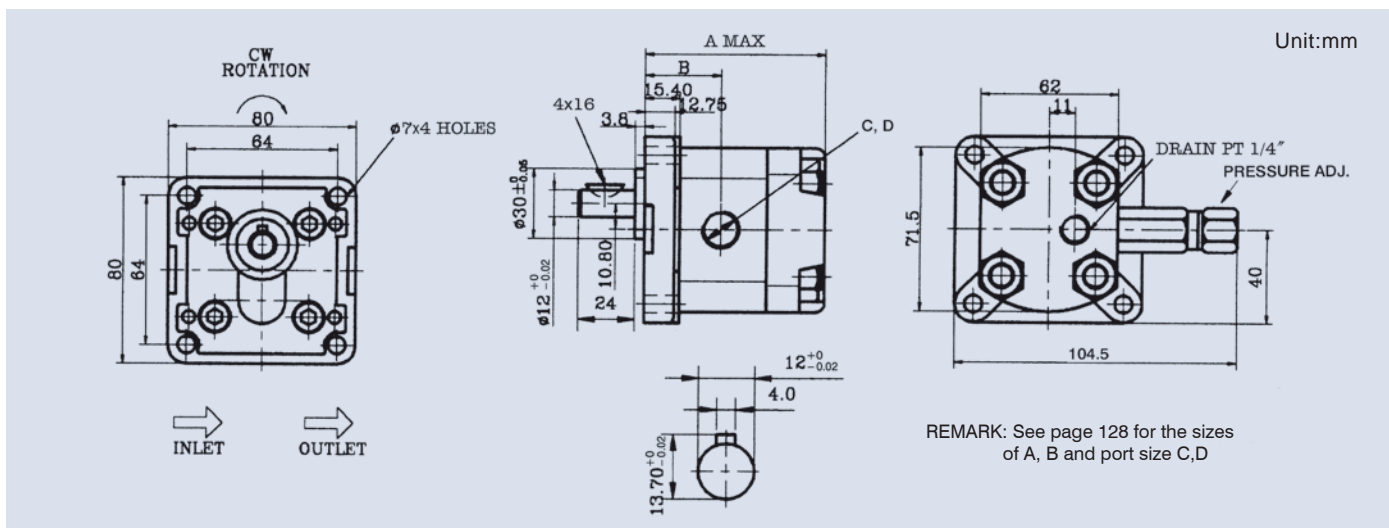

GEAR PUMP WITH RELIEF VALVE + LIFT VALVE

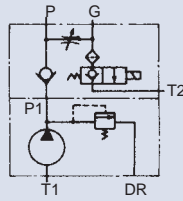

How to order

PR1 - F - ✖ - R - 4BJ - V2064 - ✖

1 2 3 4 5 6 7

1	Model
2	Mounting type F: Flange type L: Foot type
3	Displacement cc/rev
4	Rotation R: Clockwise L: Counter-clockwise
5	Mounting flange 4BJ: JIS 4-Bolt
6	V2064: Lift valve
7	Coil voltage A11: AC110V (50/60 Hz) A22: AC220V (50/60 Hz) D12: DC12V D24: DC24V

Specifications

(Refer to page 135)

Working pressure: 210 bar (3000 psi)

Displacement: 2 cc/rev - 12 cc/rev

Mounting flange: JIS 4-Bolt

Dimensions

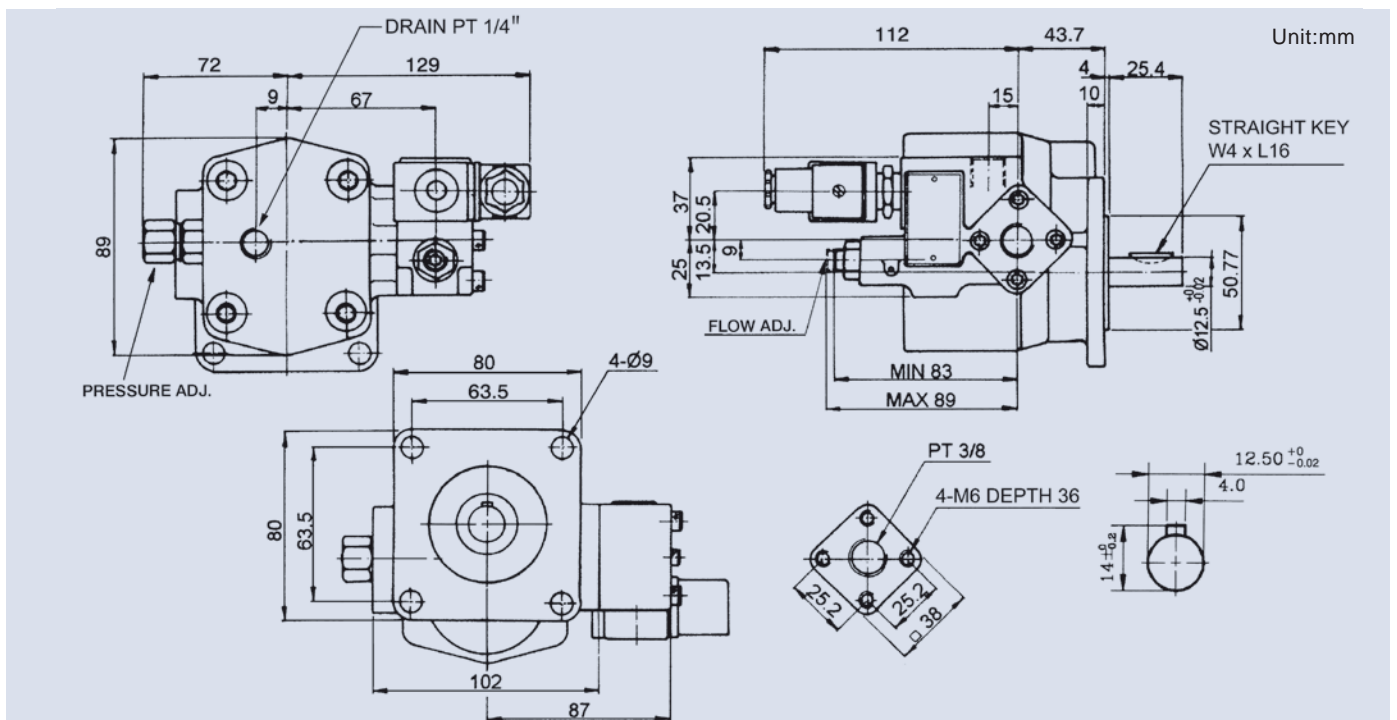

GEAR PUMP WITH RELIEF VALVE + LIFT VALVE

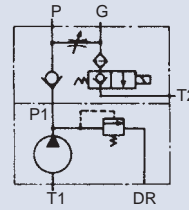

How to order

PR2 - F - ☒ - R - 4B - 2064 - ☒

1	2	3	4	5	6	7
1	Model					
2	Mounting type F: Flange type L: Foot type					
3	Displacement cc/rev					
4	Rotation R: Clockwise L: Counter-clockwise					
5	Mounting flange 2B: SAE 2-Bolt 4BD: DIN 4-Bolt 4BE: European 4-Bolt					
6	V2064: Lift valve					
7	Coil voltage A11: AC110V(50/60 Hz) A22: AC220V(50/60 Hz) D12: DC12V D24: DC24V					

Specifications

(Refer to page 136)

Working pressure: 210 bar (3000 psi)

Displacement: 1 cc/rev ~ 7.8 cc/rev

Dimensions

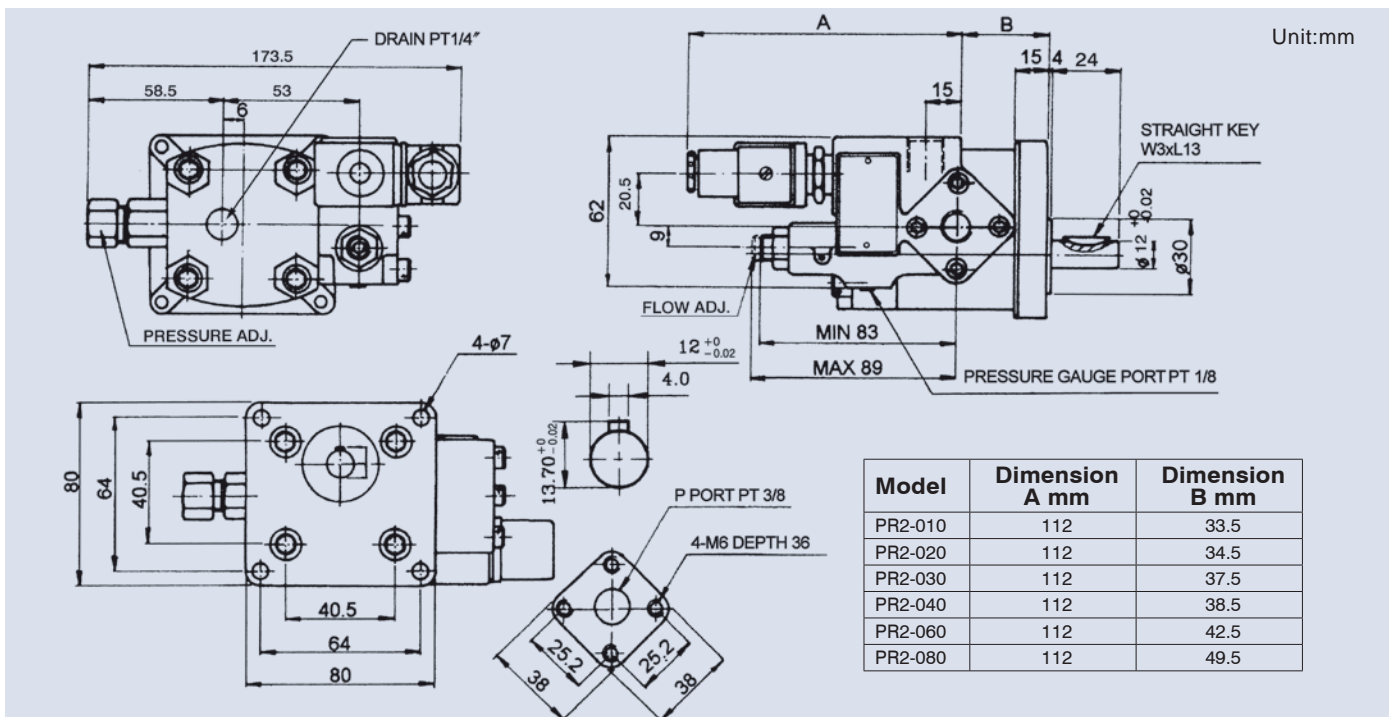

DUMP HOIST PUMP

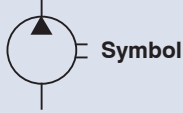

How to order

KP - 55

- 1 Model
- 2 Displacement cc/rev

Specifications

Model	Displacement (cc/rev)	Max. Pressure (bar)	Rated Pressure (bar)	Start-up Pressure of Control Valve (bar)	Running Speed (rpm)		Shaft Diameter (mm)	weight (kg)
					Max.	Min.		
KP-35	34.7	175	45	10	1800	350	22	10
KP-55	54.2			13				13
KP-75	72	210	70	14			25	21
KP-1403	136			15			30	37

Recommend oil: Mobile DTE 26 or equivalent

Dimensions

KP-55

Unit:mm

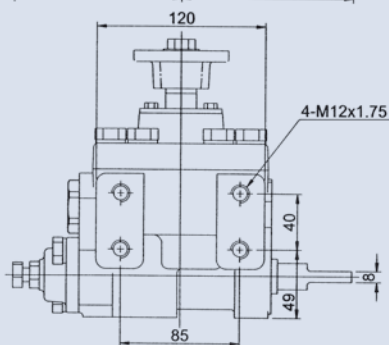
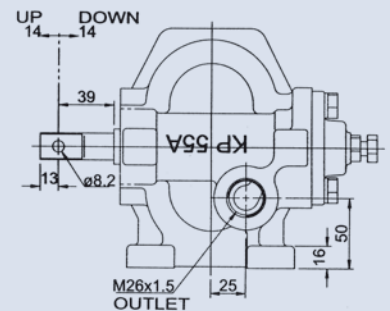
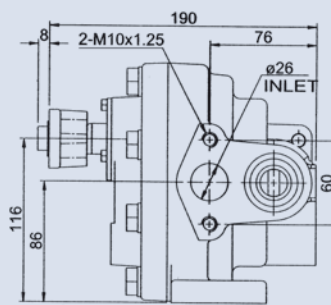
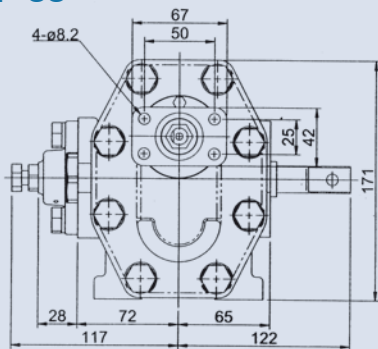

Performance curves

KP-55

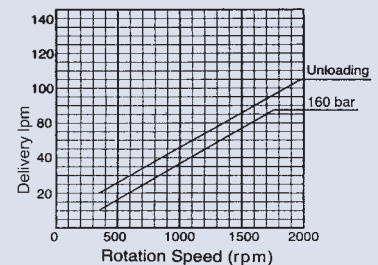
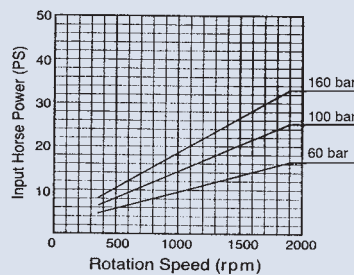

DUMP HOIST PUMP

Dimensions

KP-75

Unit:mm

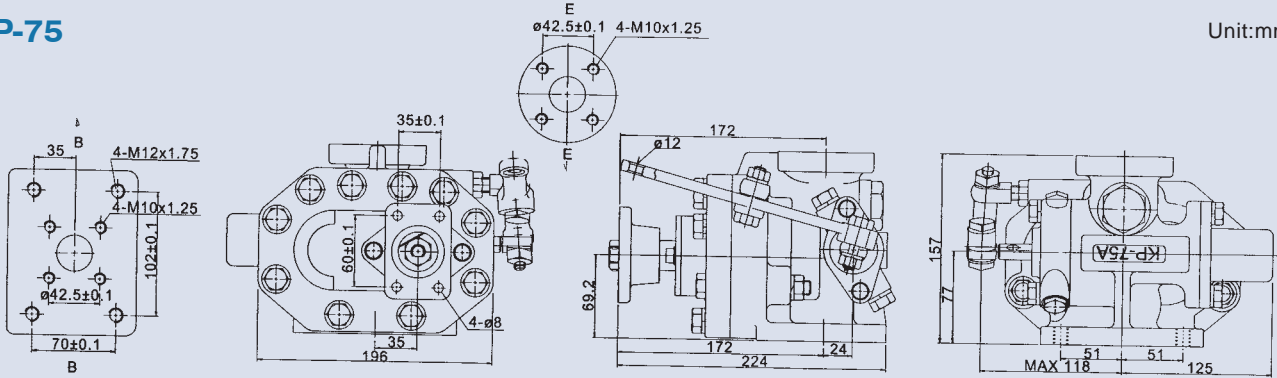

Performance curves

KP-75

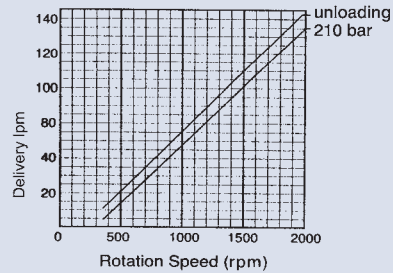
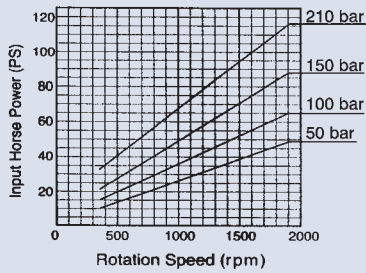

Dimensions

KP-1403

Unit:mm

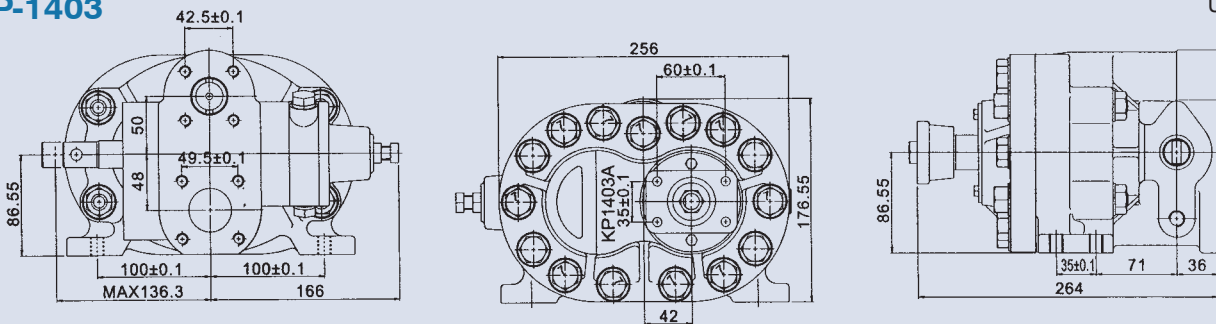

Performance curves

KP-1403

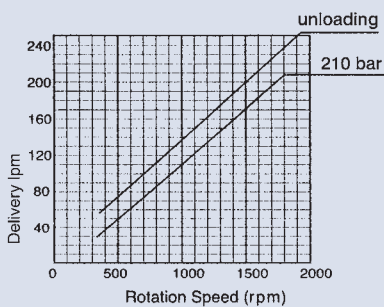
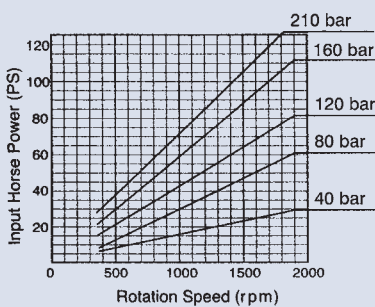

HAND PUMP, FOOT PUMP

E



H-B Hydraulic Hand Pump



H-C Hydraulic Hand Pump



H-A Hydraulic Hand Pump



F-B Hydraulic Foot Pump

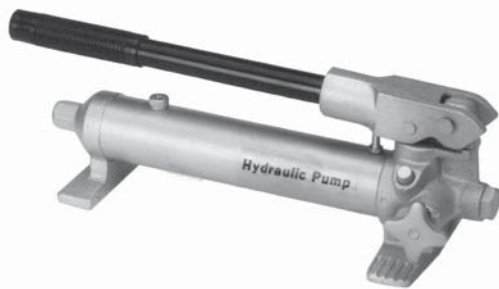

H-A2 Hydraulic Hand Pump

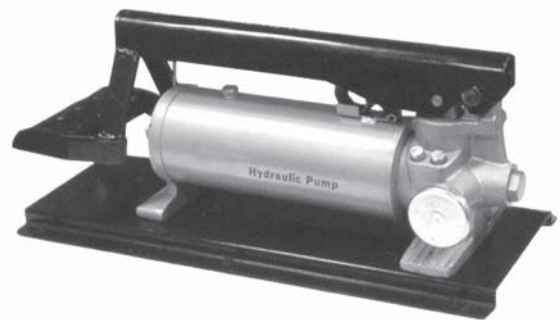

F-C Hydraulic Foot Pump

Specifications

Model	Max. Pressure (bar)		Output Per Stroke (cc)		Reservoir Capacity (cc)	Oil Port Thread	Speed	Size (mm) L×W×H	Weight (kg)
	1ST Stage	2ND Stage	1ST Stage	2ND Stage					
H-A	-	700	-	2.8	600	1/4 NPT	Single	530×120×125	6
H-B	20	700	13	2.8	700	3/8 NPT	Two	600×150×150	8
H-A2	-	700	-	2.26	350	1/4 NPT	Single	350×120×125	4.4
F-B	20	700	13	2.8	700	3/8 NPT	Two	708×174×170	11
F-C	20	700	13	2.8	700	3/8 NPT	Two	474×174×192	11
H-C	20	700	13	2.8	2500	3/8 NPT	Two	713×142×200	12

AIR HYDRAULIC PUMP

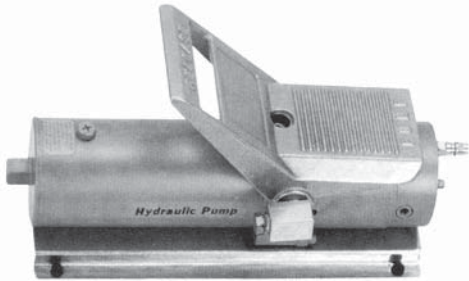

AP-801

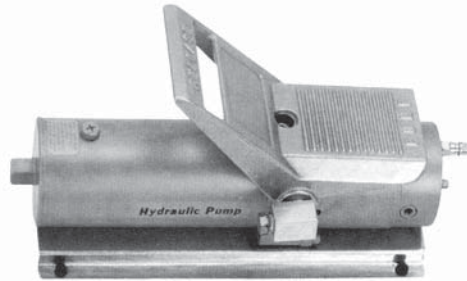

AP-901



AP-1000
AP-3000

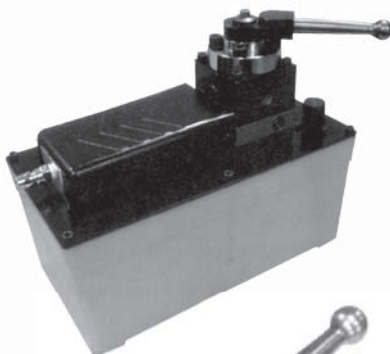
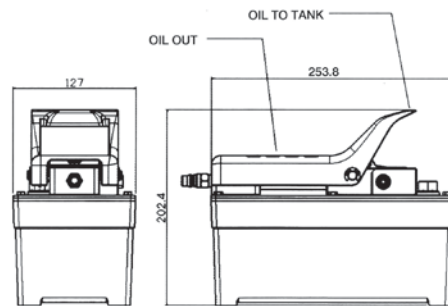

AP-3001

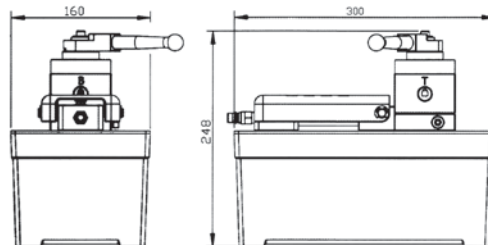

HV-700

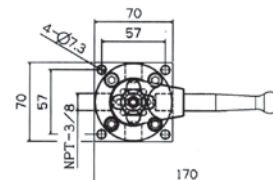
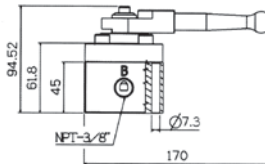
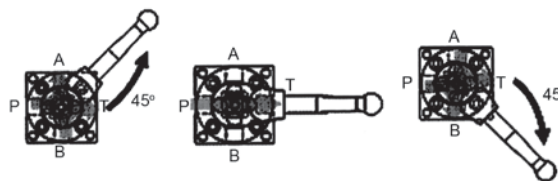

Specifications

Model	Max. Pressure (bar)	Output Flow Rated (cc/min)		Air Pressure Range (bar)	Reservoir Capacity (cc)	Usable Oil Capacity (cc)	Oil Port Thread	Acting	Dimension (mm)	Weight (kg)
		Unload	Load							
AP-801	700	500	100	5-11	900	700	1/4 NPT	Single	366x170x178	6.7
AP-901		700			1000	800			370x170x178	6.7
AP-1000		1280	160		1500	1000	3/8 NPT	Double	260x130x200	6.6
AP-3000		1280			300x160x245	10				
AP-3001					300x160x245	11.2				
HV-700		※ 4-way / 3-position ※ Lever operated, detent positioned			※ Application: Single-or double-acting cylinder ※ Provides "advance", "hold" and "return".				1.26	

SYNCHRONOUS FLOW DIVIDER

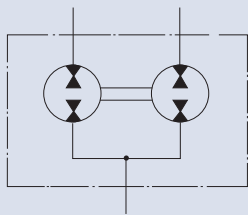

Symbol



How to order

DFM - 3 - 02A - 11

1 2 3 4

- 1 Model
- 2 Series number
- 3 Stations 02A: 2 Stations 03A: 3 Stations 04A: 4 Stations
- 4 Displacement (cc/rev) 4 cc/rev~35 cc/rev

Specifications

Model	Displacement (cc/rev)	Max. Pressure bar (psi)	Speed (rpm)		Port Size		A(mm)	B(mm)	Weight (kg)
			Loaded	Unloaded	In	Out			
DFM-302A-6*	6	210 (3000)	1200	2000	PT 3/4"	PT 1/2"	52	263.6	4.6
DFM-302A-8*	8.4						55	269.6	4.7
DFM-302A-11*	11						60	279.6	4.98
DFM-302A-13*	13						64	287.6	4.98
DFM-302A-14*	14.3						66	291.6	5.53
DFM-302A-17*	16.5						70	299.6	5.53
DFM-302A-19*	19.2						74	303.6	6.13
DFM-302A-23*	23				81	321.6	6.13		
DFM-302A-25*	25				84	327.6	6.13		
DFM-302A-28*	28				88	335.6	6.67		
DFM-302A-30*	30				92	313.6	6.67		
DFM-302A-35*	35				102	323.6	6.9		

Dimensions

DFM-302A

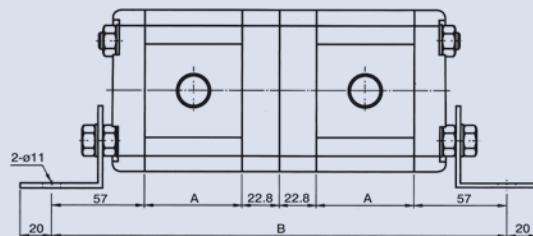

Unit:mm

DFM-304A

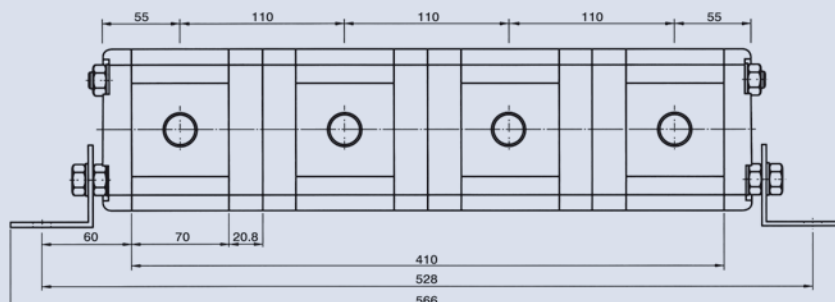

RADIAL PISTON TYPE LOW SPEED HIGH TORQUE HYDRAULIC MOTOR

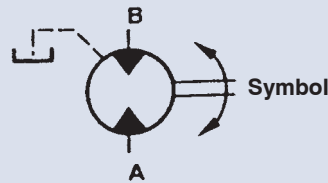

How to order

B - MRCN - **** - * - * - ***

1	2	3	4	5	6
1	Series number				
2	Model MRCN: 200~1250 cc/rev MRC: 1400~3500 cc/rev				
3	Normal displacement cc/rev				
4	Shaft type N: Splined shaft P: Parallel shaft				
5	Option None: No fix hole T: Shaft with fix hole				
6	Shaft rotation None: Clockwise L: Counter-clockwise				

Dimensions

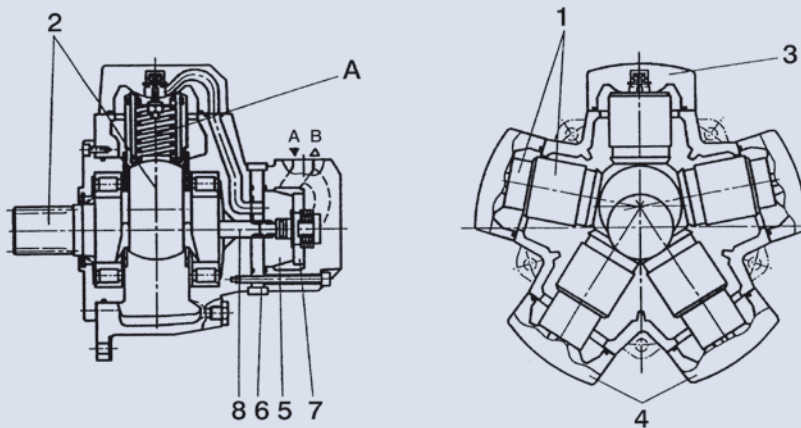

Section-Functional Description

The outstanding performance of this motor is the result of an original and patented design. The principle is to transmit the effort from the stator to the rotating shaft (2) by means of a pressurized column of oil (A) instead of the more common connecting rods, pistons, pads and pins.

This oil column is contained by a telescopic cylinder (1) with a mechanical connection at the lips at each end which seal against the spherical surfaces (3) of the cylinder heads (4) and the spherical surface of the rotating shaft.

These lips retain their circular cross section when stressed by the pressure so there is no alteration in the sealing geometry. The particular selection of materials and optimisation of design has minimized both the friction and the leakage.

Another advantage of this design stems from the elimination of any connecting rods, the cylinder can only expand and retract linearly so there are no transverse components of the thrust. This means no oval wear on the moving parts and no side forces on the cylinder joints.

A consequence of this novel design is a significant reduction in weight and overall size compared with other motors of the same capacity.

The timing system is realized by means of a rotary valve (5) driven by the rotary valve driving shaft (8) that it is connected to the rotating shaft.

The rotary valve rotates between the rotary valve plate (6) and the reaction ring (7) which are fixed with the motor's housing. This timing system is also of a patented design being pressure balanced and self compensating for thermal expansion. The advantages of this type of valve coupled with a revolutionary cylinder arrangement produce a motor with extremely high values of mechanical and volumetric efficiency. The torque output is smooth even at very low speed and the motor gives a high performance starting under load.

RADIAL PISTON TYPE LOW SPEED HIGH TORQUE HYDRAULIC MOTOR

Specifications

Model	Displacement (cc/rev)	Specific toque (nm/bar)	Max. Input Pressure (bar)			Max. Pressure Difference (intermittent)	Max. Case Pressure (bar)	Max. Speed (rpm)	Max. Power (kw)	Weight (kg)
			Continuous	Intermittent	Peak					
B1-MRCN200	199	3.2	210	250	300	210	5	450	27	40
B1-MRCN250	249	4.0	210	250	300	210	5	425	33	40
B1-MRCN300	299	4.8	210	250	300	210	5	403	38	40
B1-MRCN350	349	5.6	210	250	300	210	5	384	42	40
B1-MRCN400	382	6.1	210	250	300	210	5	350	42	42
B12-MRCN400	382	6.1	210	250	300	210	5	350	42	42
B2-MRCN400	410	6.5	210	250	300	210	5	470	61	72
B2-MRCN450	452	7.2	210	250	300	210	5	450	64	72
B2-MRCN500	495	7.9	210	250	300	210	5	430	67	72
B2-MRCN600	594	9.5	210	250	300	210	5	410	77	72
B2-MRCN700	693	11.0	210	250	300	210	5	390	85	72
B2-MRCN800	792	12.6	210	250	300	210	5	350	87	72
B23-MRCN800	792	12.6	210	250	300	210	5	350	87	74
B3-MRCN850	855	13.6	210	250	300	210	5	320	86	94
B3-MRCN900	896	14.3	210	250	300	210	5	320	90	94
B3-MRCN1000	998	15.9	210	250	300	210	5	290	91	94
B3-MRCN1100	1099	17.5	210	250	300	210	5	270	93	94
B3-MRCN1200	1201	19.1	210	250	300	210	5	250	95	94
B3-MRCN1250	1241	19.8	210	250	300	210	5	240	94	94
B4-MRC1400	1419	22.6	210	250	300	210	5	260	116	152
B4-MRC1600	1589	25.3	210	250	300	210	5	230	115	152
B4-MRC1800	1816	28.9	210	250	300	210	5	210	120	152
B4-MRC2000	1986	31.6	210	250	300	210	5	200	125	152
B4-MRC2100	2100	33.4	210	250	300	210	5	200	132	152
B41-MRC1400	1419	22.6	210	250	300	210	5	260	116	160
B41-MRC1600	1589	25.3	210	250	300	210	5	230	115	160
B41-MRC1800	1816	28.9	210	250	300	210	5	210	120	160
B41-MRC2000	1986	31.6	210	250	300	210	5	200	125	160
B41-MRC2100	2100	33.4	210	250	300	210	5	200	132	160
B42-MRC1400	1419	22.6	210	250	300	210	5	260	116	152
B42-MRC1600	1589	25.3	210	250	300	210	5	230	115	152
B5-MRC2400	2402	38.2	210	250	300	210	5	220	159	312
B5-MRC2800	2808	44.7	210	250	300	210	5	210	177	312
B5-MRC3000	2993	47.6	210	250	300	210	5	210	189	312
B5-MRC3100	3104	49.4	210	250	300	210	5	200	186	312
B5-MRC3200	3215	51.2	210	250	300	210	5	200	193	312
B5-MRC3500	3473	55.3	210	250	300	210	5	190	198	312
B51-MRC2400	2402	38.2	210	250	300	210	5	220	159	312
B51-MRC2800	2808	44.7	210	250	300	210	5	210	177	312
B51-MRC3000	2993	47.6	210	250	300	210	5	210	189	312
B51-MRC3100	3104	49.4	210	250	300	210	5	200	186	312
B51-MRC3200	3215	51.2	210	250	300	210	5	200	193	312
B51-MRC3500	3473	55.3	210	250	300	210	5	190	198	312

RADIAL PISTON TYPE LOW SPEED HIGH TORQUE HYDRAULIC MOTOR

Dimensions

B1-MRCN 200, 250, 300, 350, 400

Unit:mm

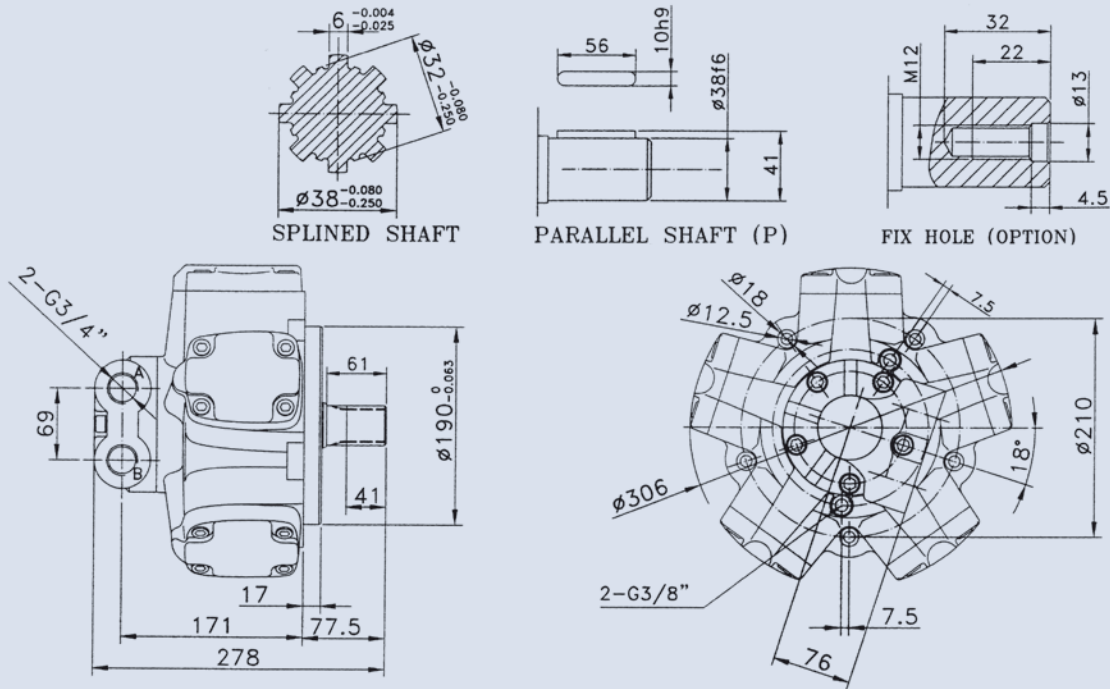

B12-MRCN 400

Unit:mm

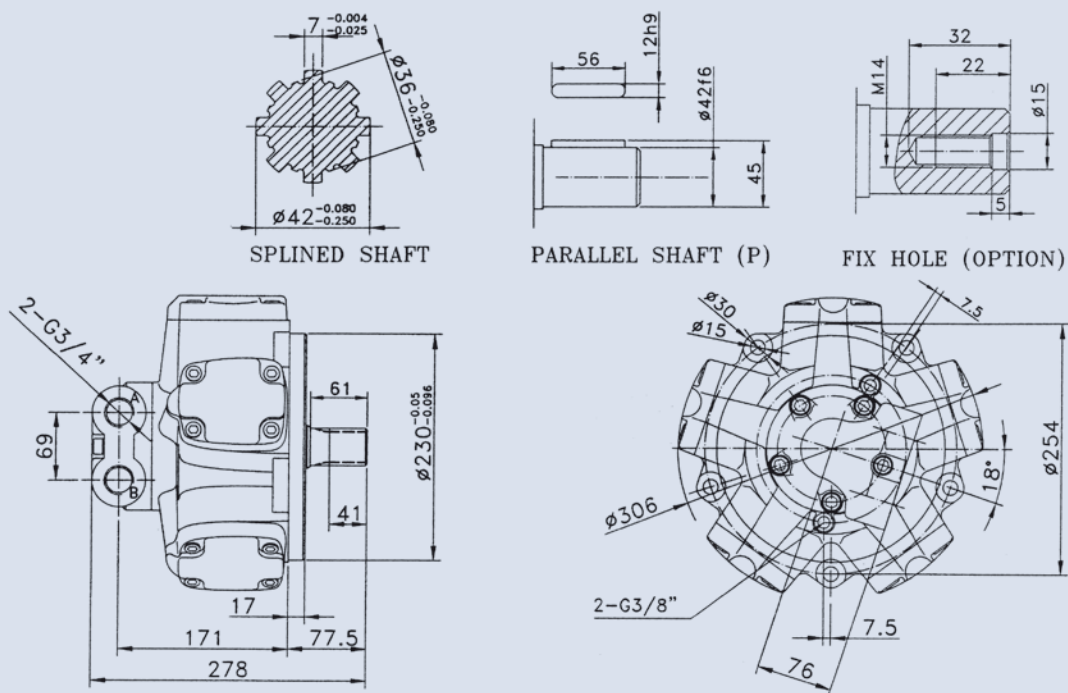

RADIAL PISTON TYPE LOW SPEED HIGH TORQUE HYDRAULIC MOTOR

Dimensions

B2-MRCN 400, 450, 500, 600, 700, 800

Unit:mm

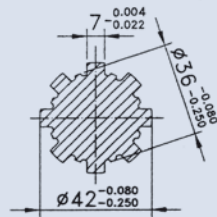

SPLINED SHAFT

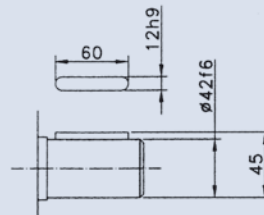

PARALLEL SHAFT (P)

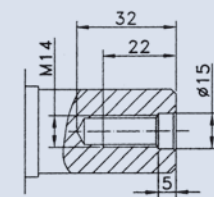

FIX HOLE (OPTION)

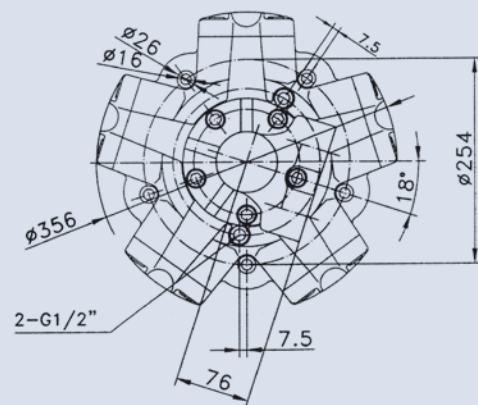
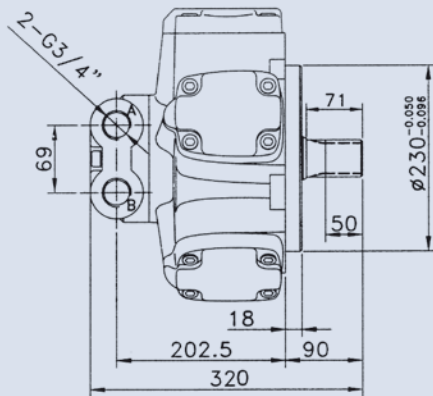

B23-MRCN 800

Unit:mm

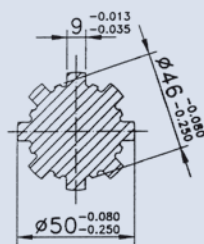

SPLINED SHAFT

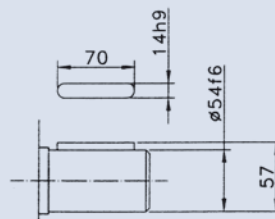

PARALLEL SHAFT (P)

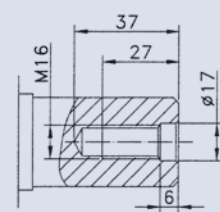

FIX HOLE (OPTION)

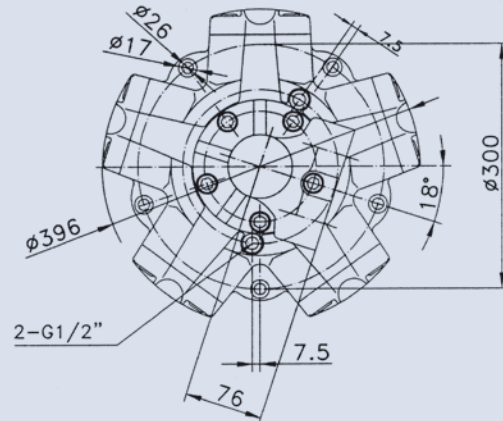
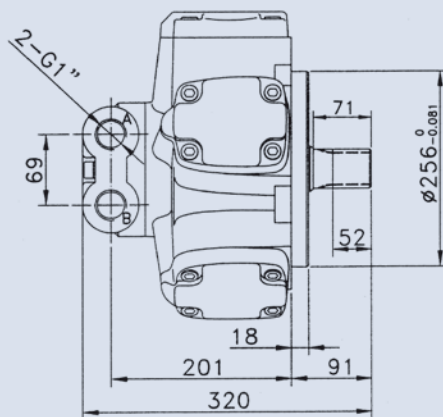

RADIAL PISTON TYPE LOW SPEED HIGH TORQUE HYDRAULIC MOTOR

Dimensions

B3-MRCN 850, 900, 1000, 1100, 1200, 1250

Unit:mm

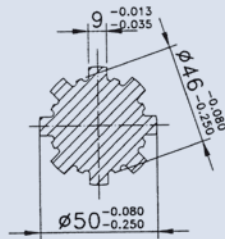

SPLINED SHAFT

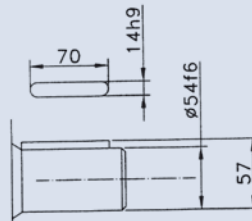

PARALLEL SHAFT (P)

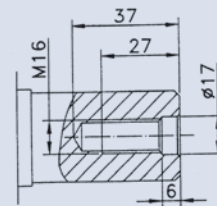

FIX HOLE (OPTION)

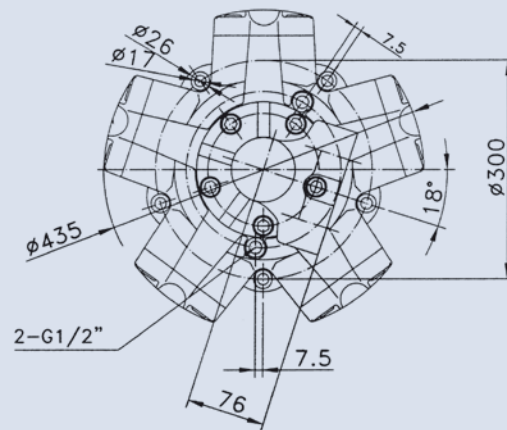
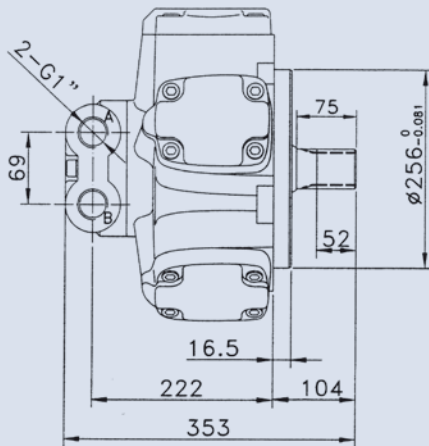

B4-MRC 1400, 1600, 1800, 2000, 2100

Unit:mm

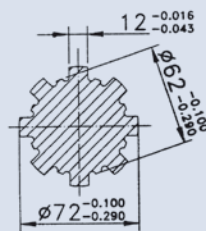

SPLINED SHAFT
62 UNI 221

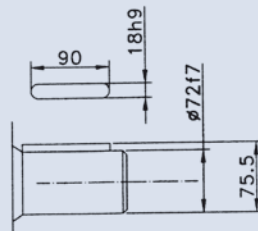

PARALLEL SHAFT (P)

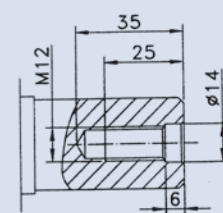

FIX HOLE (FOR ALL SHAFT)

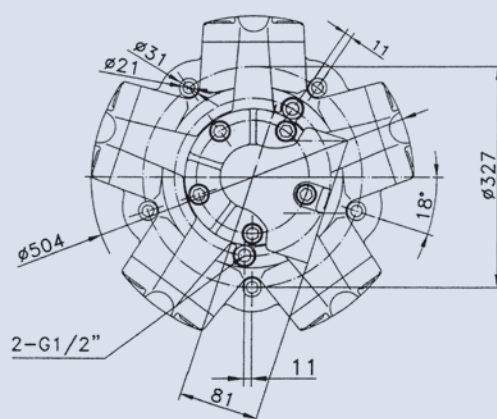
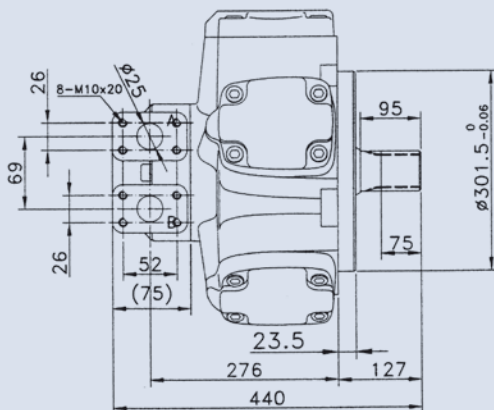

RADIAL PISTON TYPE LOW SPEED HIGH TORQUE HYDRAULIC MOTOR

Dimensions

B5-MRC 2400, 2800, 3000, 3100, 3200, 3500

Unit:mm

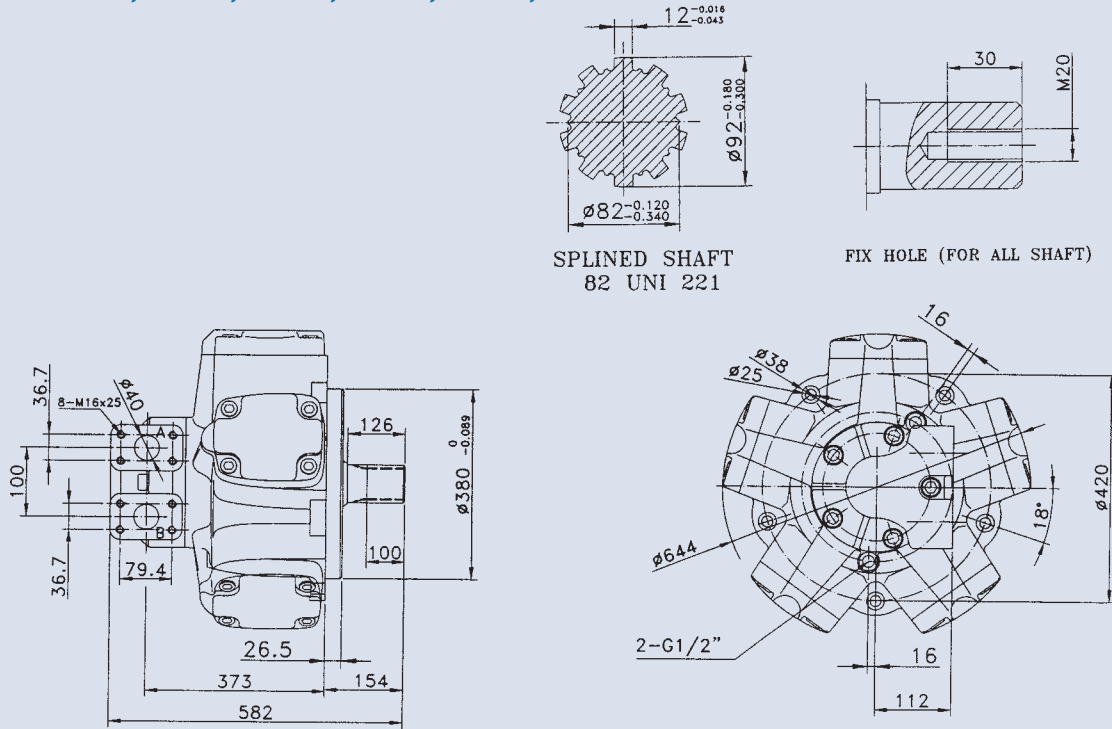

B51-MRC 2400, 2800, 3000, 3100, 3200, 3500

Unit:mm

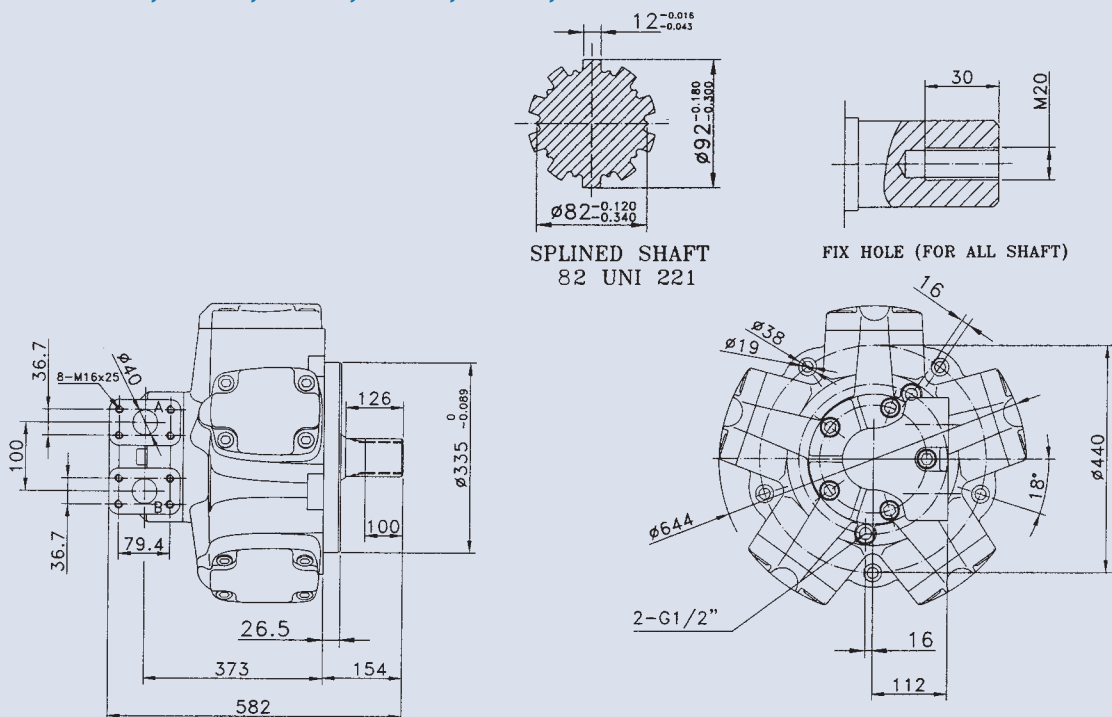

HIGH PERFORMANCE VANE MOTOR

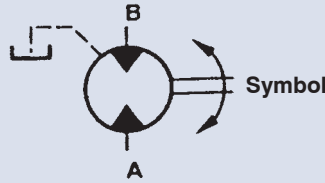

H

How to order

KVM4※C \ KVM4※CI - 055 - 1 N 00 - A 1 02 ※

1 2 3 4 5 6 7 8 9 10

1	Series external drain ※=S: Severe duty type
2	Series internal drain ※=S: Severe duty type
3	Torque 024=0.39 Nm/bar 027=0.45 Nm/bar 031=0.55 Nm/bar 043=0.74 Nm/bar 055=0.93 Nm/bar 067=1.13Nm/bar 075=1.27 Nm/bar
4	Shaft type 1-Keyed (SAE B) 2-Keyed (no SAE) 3-Splined (SAE B) 4-Splined (SAE BB) 5-Keyed
5	Rotation N-Bi-directional KVM4CI-KVM4SCI: Drain port is plugged Viewed from shaft end CW: Clockwise rotation A=inlet B=outlet CCW: Counter-clockwise rotation A=outlet B=inlet
6	Porting combination 00: Normal
7	Design letter
8	Seal class 1-S1 (KVM4C) 5-S5 (KVM4SC)
9	Port connections 01=SAE threaded port, SAE drain 02=SAE 4 bolt flange, UNC threaded-SAE drain 04=SAE 4 bolt flange, UNC threaded-BSPP drain M4=SAE 4 bolt flange, metric threaded-BSPP drain
10	Modifications Weight: 18.2 kgs

REAR PORT

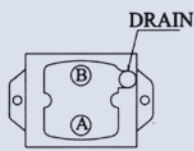

00

SIDE PORTS

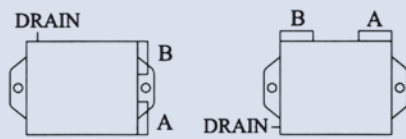

01

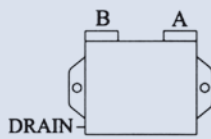

02

OPPOSITE PORTS

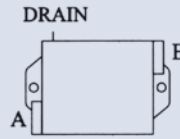

03

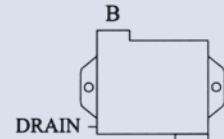

04

Porting combination

Specifications

Model	Series	Displacement (cc/rev)	Input flow at 2000 rpm		Torque T at 2000 rpm		Power output at 2000 rpm		Max. Pressure (bar)	Max. (rpm)
			Theoretical	at 175 bar	at 175 bar		at 175 bar			
			(ℓ /min)	(ℓ /min)	in.lbs	Nm	HP	kw		
KVM4C }	024	24.4	49.0	67.0	535.4	60.5	17.0	12.7	175	4000
	027	28.2	56.0	74.0	619.5	70.0	19.7	14.7		
	031	34.5	69.0	87.0	768.0	86.8	24.0	18.0		
	043	46.5	93.0	111.0	1062.0	120.0	33.6	25.1		
KVM4SC	055	58.8	118.0	136.0	1318.6	149.0	41.8	31.2		
	067	71.1	142.0	160.0	1504.5	170.0	47.7	35.6		
	075	80.1	160.0	178.0	1752.2	198.0	55.6	41.5		

HIGH PERFORMANCE VANE MOTOR

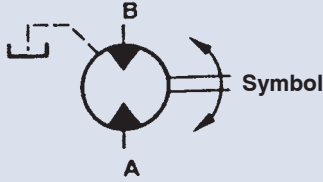

H

How to order

KVM4※D \ KVM4※DI - 138 - 1 N 00 - B 1 02 ※

1	Series external drain ※=S: Severe duty type
2	Series internal drain ※=S: Severe duty type
3	Torque 062=1.04 Nm/bar 074=1.22 Nm/bar 088=1.45 Nm/bar 102=1.68 Nm/bar 113=1.86 Nm/bar 128=2.11 Nm/bar 138=2.30 Nm/bar
4	Shaft type 1-Keyed (SAE C) 3-Splined (SAE C) S-Splined (SAE J718C)
5	Rotation N-Bi-directional KVM4DI-KVM4SDI: Drain port is plugged Viewed from shaft end CW: Clockwise rotation A=inlet B=outlet CCW: Counter-clockwise rotation A=outlet B=inlet
6	Porting combination 00: Normal
7	Design letter
8	Seal class 1-S1 (KVM4D) 5-S5 (KVM4SD)
9	Port connections 01=SAE threaded port, SAE drain 02=SAE 4 bolt flange, UNC threaded-SAE drain 04=SAE 4 bolt flange, UNC threaded-BSPP drain M4=SAE 4 bolt flange, metric threaded-BSPP drain
10	Modifications Weight: 29.91 kgs

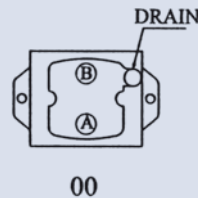

Porting combination
00-Normal

Specifications

Model	Series	Displacement (cc/rev)	Input flow at 2000 rpm		Torque T at 2000 rpm		Power output at 2000 rpm		Max. Pressure (bar)	Max. (rpm)
			Theoretical	at 175 bar	at 175 bar		at 175 bar			
			(ℓ/min)	(ℓ/min)	in.lbs	Nm	HP	kw		
KVM4D	062	65.1	130.0	154.0	1460.0	165.0	46.4	34.6	175	4000
	074	76.8	154.0	178.0	1770.0	200.0	56.2	41.9		
	088	91.1	182.0	206.0	2088.5	236.0	66.2	49.4		
	102	105.5	211.0	241.0	2336.3	264.0	74.1	55.3		
KVM4SD	113	116.7	233.0	257.0	2655.0	300.0	84.2	62.8		
	128	132.4	265.0	289.0	3009.0	340.0	95.5	71.2		
	138	144.4	289.0	313.0	3292.0	372.0	104.5	77.9		

HIGH PERFORMANCE VANE MOTOR

Dimensions

KVM4✳D

Unit:mm

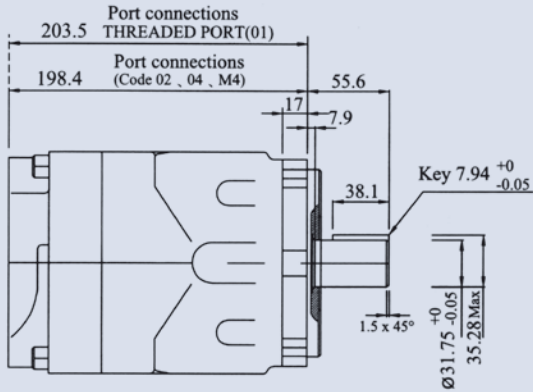

Shaft Code 1
(Keyed SAE B)

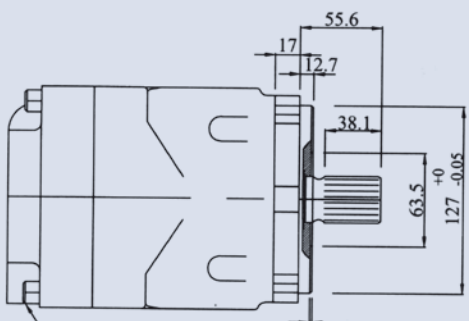
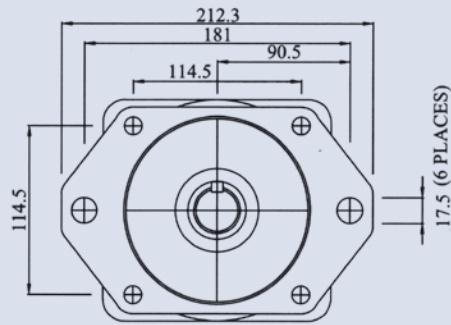

MOUNTING TORQUE 133ft.lbs
(180 Nm)

Shaft Code 3
SAE C splined shaft
Class 1-J498 b
12/24 d.p. 14 teeth
30° pressure angle
flat root side fit.

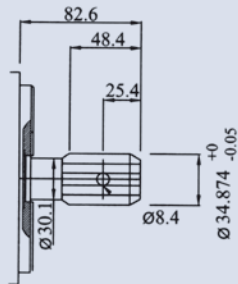
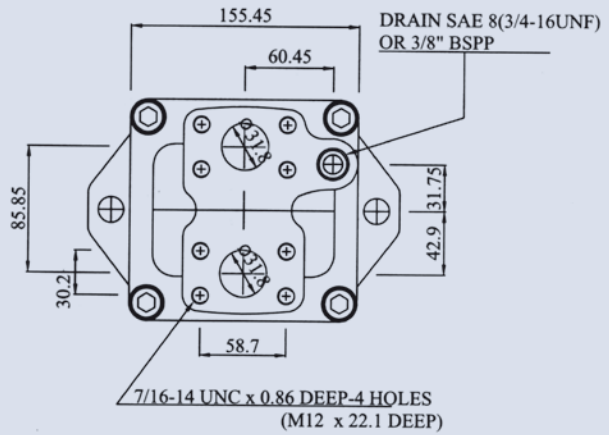

Shaft Code S
ISO 500-3 splined
shaft 16/32 d.p.
21 teeth 30°
pressure angle
flat root side fit.

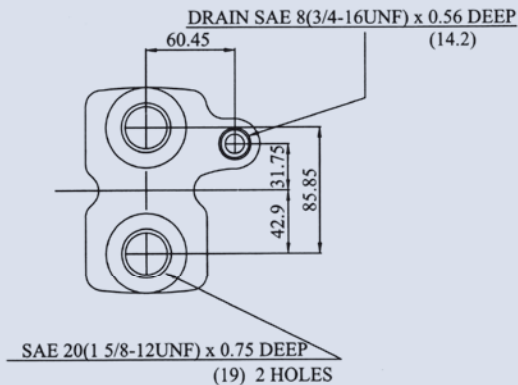

SAE THREADED PORT

H

HIGH PRESSURE GEAR MOTOR

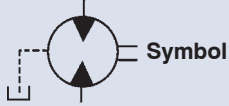

H

How to order

2M - M - 2 - U - ☼

- 1 Model Covers: Cast iron Body: Aluminum
- 2 Mounting type M: Flange type 2-bolt
- 3 Shaft type 1: Parallel shaft 2: Splined shaft
- 4 Port size
- 5 Displacement cc/rev

Specifications

Model	Displacement (cc/rev)	Pressure (bar)		Speed (rpm)	At 100 bar, 1000 rpm		Dimensions inch (mm)		Port Size	Weight (kg)
		Continuous	Max.		Power (kw)	Toque (Nm)	A	L		
05	5.0	250	300	600-4000	0.70	6.7	1.687 (42.86)	3.493 (88.71)	UNF-12 1-1/16"-12	4.17
07	7.0				0.98	9.4	1.746 (44.36)	3.611 (91.71)		4.25
08	8.4				1.18	11.3	1.796 (45.61)	3.709 (94.21)		4.31
09	9.5				1.33	12.7	1.825 (46.36)	3.768 (95.71)		4.38
11	11.3				1.59	15.2	1.884 (47.86)	3.886 (98.71)		4.55
14	14.0				1.97	18.8	1.963 (49.86)	4.044 (102.71)		4.72
16	16.0				2.25	21.5	2.022 (51.36)	4.162 (105.71)		4.81
18	18.0				2.53	24.1	2.081 (52.86)	4.280 (108.71)		4.95
20	19.5				2.74	26.2	2.160 (54.86)	4.437 (112.71)		5.03
22	21.5				3.02	28.8	2.180 (55.36)	4.477 (113.71)		5.12
24	23.5	180	210	600-2500	3.30	31.5	2.258 (57.36)	4.634 (117.71)	UNF-16 1-5/16"-12	5.20
26	25.0				3.51	39.0	2.317 (58.86)	4.752 (120.71)		5.26
28	28.0				3.93	37.6	2.396 (60.86)	4.910 (124.71)		5.32
30	30.0				4.22	40.3	2.475 (62.86)	5.067 (128.71)		5.39
33	33.0				4.63	44.3	2.554 (64.86)	5.225 (132.71)		5.45

Dimensions

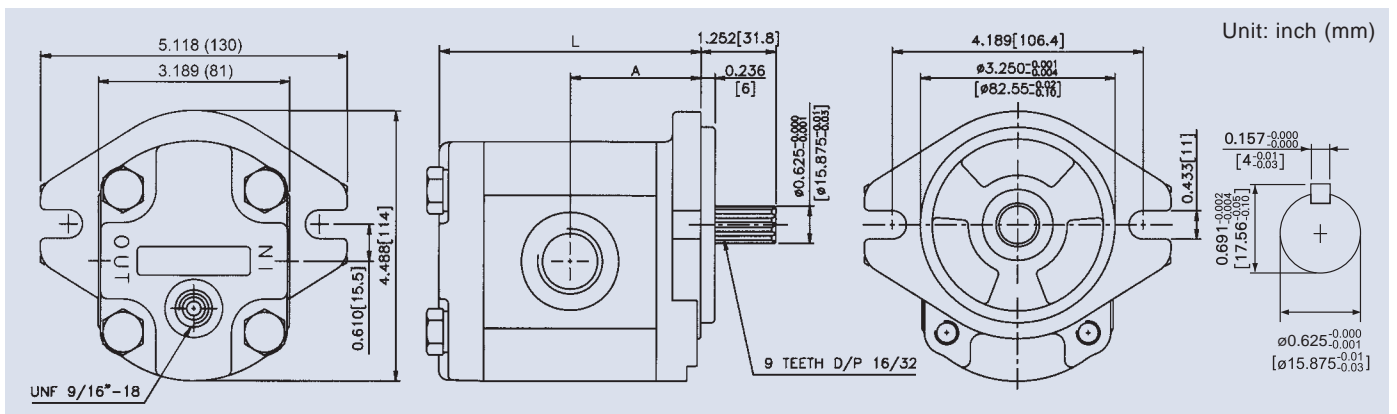

POWER PACK

Manifold functions

MR&MK Type

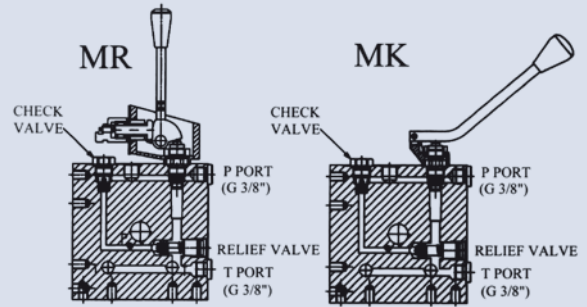
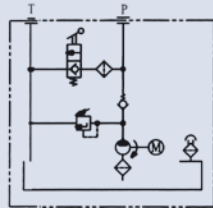
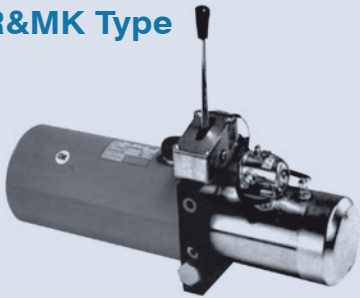

"S" Type

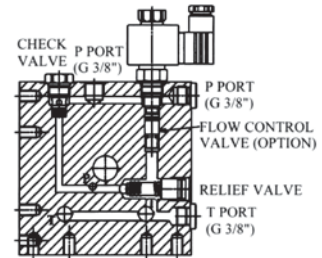
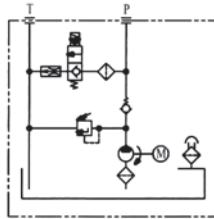
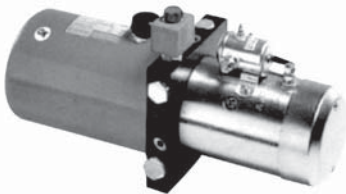

"N" Type

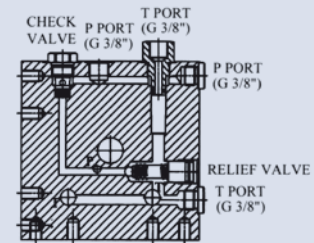
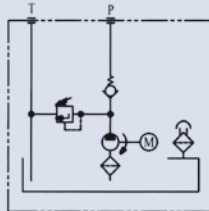
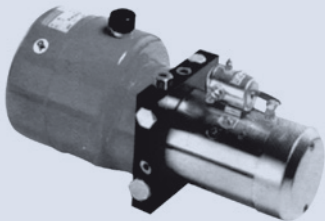

"A" Type

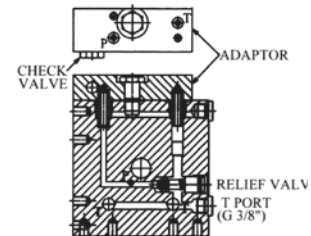
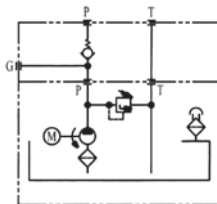
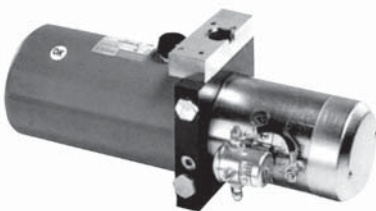

"A" Type + Cetop 03

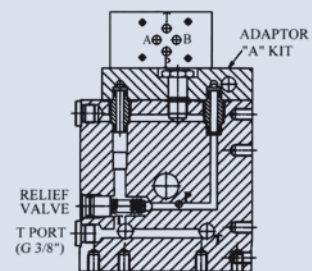
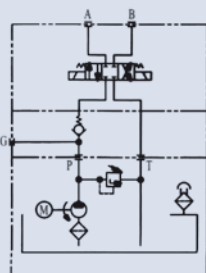
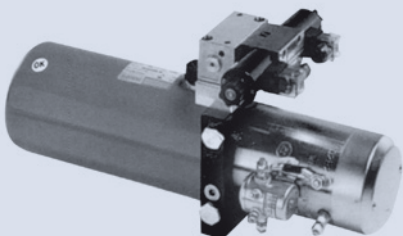

POWER PACK

Manifold functions Hi-Lo pressure

"N" Type

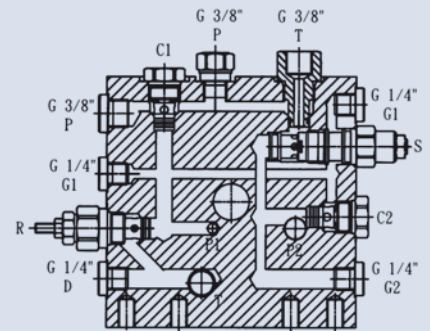
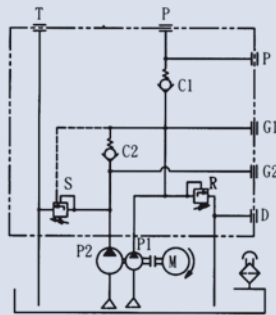
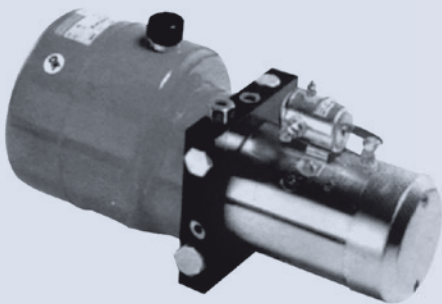

"S" Type

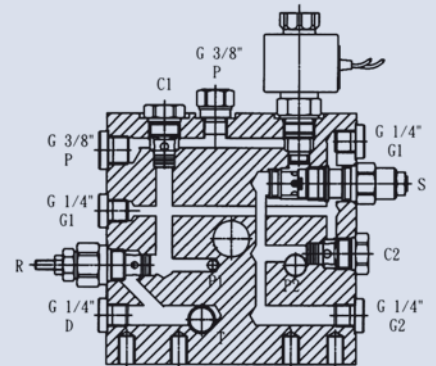
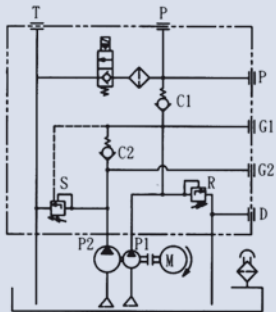
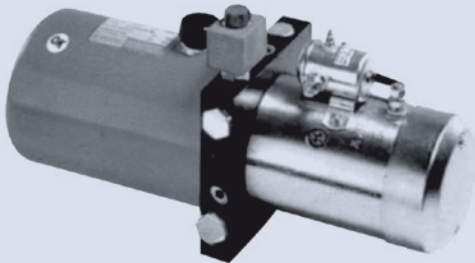

"A" Type + Cetop 03

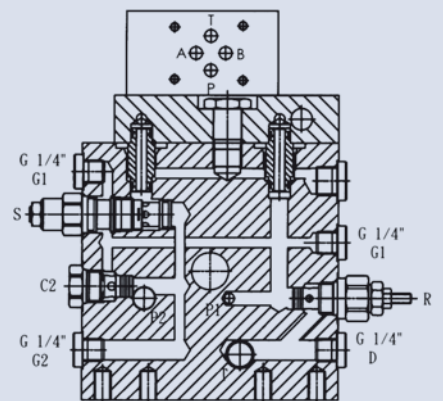
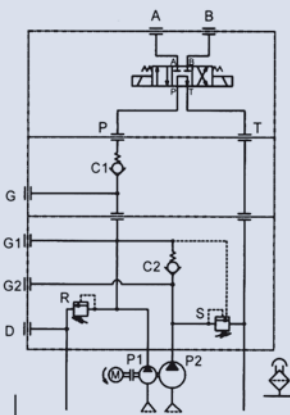
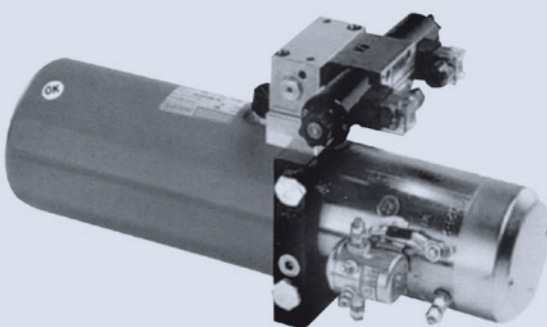

POWER PACK

DC MOTORS

How to order

T - CN24 - H - 10 - S - 10 - A - A - N - D ** ***

1 Motor Temperature protector T: With temperature protector N: Without temperature protector

2 DC motor

2		550W Low-speed motor	L		3000W Compound wound motor (DC24V)
3		800W Compound wound motor			2500W Compound wound motor (DC12V)
5		550W Permanent magnet motor	E		Earth return (motor with 1 terminal)
8		800W Permanent magnet motor	N		Insulate return (motor with 2 terminals)
C		2000W Compound wound motor (DC24V)		1 2	DC12V Motor
		1500W Compound wound motor (DC12V)		2 4	DC24V Motor
S		2000W Series wound motor (DC24V)	N	N	Without motor
		1500W Series wound motor (DC12V)	X	X	Special
			P	P	2200W Compound wound motor (DC24V)
					1600W Compound wound motor (DC12V)

3 Mounting type

H: Horizontally mounted V: Vertically mounted X: Special mounting
 HN: Horizontally mounted without tank VN: Vertically mounted without tank

4 Tank size

ø140 mm Dia		ø180 mm Dia		
10	1.0 Liters	30	3.0 Liters	XX: Special
16	1.6 Liters	40	4.0 Liters	NN: None
20	2.0 Liters	50	5.0 Liters	(working volume)
24	2.4 Liters	60	6.0 Liters	
28	2.8 Liters	80	8.0 Liters	
42	4.2 Liters			

5 Lowering valve

S: Solenoid operated (normally closed) MR: Manual operated
 T: Solenoid operated (normally open) MK: Manual operated (without switch)
 U: Solenoid operated (normally closed with manual) N: None
 V: Solenoid operated (normally open with manual) X: Special operated
 A: Adaptor for other manifold

6 Pump capacity

05: 0.5 cc/rev 07: 0.7 cc/rev 10: 1.0 cc/rev 15: 1.5 cc/rev 19: 1.9 cc/rev 23: 2.3 cc/rev
 27: 2.7 cc/rev 30: 3.0 cc/rev 35: 3.5 cc/rev 40: 4.0 cc/rev 51: 5.1 cc/rev 62: 6.2 cc/rev 73: 7.3 cc/rev

7 Hand pump

None: Without hand pump P: With hand pump (7.4 cc/stroke) X: Special hand pump assembly

8 Start switch positions

A: Same side as check valve B: Same side as relief valve C: The side opposite A D: The side opposite B N: None

9 Breather cap positions

A: Same side as check valve B: Same side as relief valve C: The side opposite A D: The side opposite B N: None

10 Flow control valve

N: None 2: 2 lpm 4: 4 lpm 6: 6 lpm 8: 8 lpm 10: 10 lpm (Rated flows)

11 Unique code

Manifold function A-Z	
	Standard manifold
D	Standard manifold With low noise relief valve

POWER PACK AC MOTORS

How to order

MF - □ - 01 - H - 10 - S - 10 - ✱ - A - A - N - D ✱ ✱ ✱
 1 2 3 4 5 6 7 8 9 10 11 12

1 AC motor

Motor dimension

Ø110	MSN	Motor without fan	Only 1/4HP
Ø140	MFS	Motor with fan	From 1/2HP to 1HP
	MSS	Motor without fan	

Motor dimension

Ø125	MSM	Motor without fan	From 1/2HP to 1HP
Ø160	MF	Motor with fan	From 1HP to 3HP
	MS	Motor without fan	

XX: Special

2 AC motor

	Standard voltages and hertz (refer to below)
A-ZZ	Special voltages and hertz on request

3 AC motor

Motor	Power	Phase	Voltages	Hertz	Rpm	Motor	Power	Phase	Voltages	Hertz	Rpm
01	1HP 4P	3	220/380	50/60	1420/1720	10	3HP 2P	3	220/380	50/60	2850/3450
02	1HP 2P	3	220/380	50/60	2850/3450	11	1/2HP 4P	1	110/220	50/60	1420/1720
03	1HP 4P	1	110/220	50/60	1420/1720	12	1/2HP 2P	1	110/220	50/60	2850/3450
04	1HP 2P	1	110/220	50/60	2850/3450	13	3/4HP 4P	1	110/220	50/60	1420/1720
05	2HP 4P	3	220/380	50/60	1420/1720	14					
06	2HP 2P	3	220/380	50/60	2850/3450	15	1/2HP 4P	3	220/380	50/60	1420/1720
07	2HP 4P	1	110/220	50/60	1420/1720	16	1/2HP 6P	3	220/380	50/60	940/1140
08	2HP 2P	1	110/220	50/60	2850/3450	17	1/4HP 4P	1	110/220	50/60	1420/1720
09	3HP 4P	3	220/380	50/60	1420/1720	18	1/4HP 4P	3	220/380	50/60	1420/1720

4 Mounting type

H: Horizontally mounted V: Vertically mounted X: Special mounting
 HN: Horizontally mounted without tank VN: Vertically mounted without tank

5 Tank size

ø140 mm Dia			ø180 mm Dia					
10	1.0 Liters	24	2.4 Liters	30	3.0 Liters	60	6.0 Liters	XX: Special
16	1.6 Liters	28	2.8 Liters	40	4.0 Liters	80	8.0 Liters	NN: None
20	2.0 Liters	42	4.2 Liters	50	5.0 Liters			(working volume)

6 Lowering valve

S: Solenoid operated (normally closed) T: Solenoid operated (normally open)
 U: Solenoid operated (normally closed with manual) V: Solenoid operated (normally open with manual)
 MR: Manual operated MK: Manual operated (without switch) N: None X: Special operated A: Adaptor for other manifold

7 Pump capacity

05: 0.5 cc/rev 07: 0.7 cc/rev 10: 1.0 cc/rev 15: 1.5 cc/rev 19: 1.9 cc/rev 23: 2.3 cc/rev
 27: 2.7 cc/rev 30: 3.0 cc/rev 35: 3.5 cc/rev 40: 4.0 cc/rev 51: 5.1 cc/rev 62: 6.2 cc/rev 73: 7.3 cc/rev

8 Hand pump

None: Without hand pump P: With hand pump (7.4 cc/stroke) X: Special hand pump assembly

9 Wire box positions A: Same side as check valve B: Same side as relief valve C: The side opposite A D: The side opposite B N: None

10 Breather cap positions A: Same side as check valve B: Same side as relief valve C: The side opposite A D: The side opposite B N: None

11 Flow control valve

N: None 2: 2 lpm 4: 4 lpm 6: 6 lpm 8: 8 lpm 10: 10 lpm (rated flows)

12 Unique code

Manifold function A-Z	
	Standard manifold
D	Standard manifold With low noise relief valve

ELECTRIC MOTOR-HOLLOW SHAFT TYPE



How to order

H H S 01 - * - 2HP - * - * - * - *
 1 2 3 4 5 6 7 8 9 10

1	Model	Motor for hydraulic pumps
2	Mounting type	H: Horizontal type V: Vertical type
3	Material of frame	S: Cast iron (normal) F: Steel A: Aluminum
4	Mounting Flang	01: Hollow shaft type (normal) 02: Motor-pump with adaptor type 03: In oil type
5	Wiring box position (viewed from fan cover)	R: Right side (normal) L: Left side U: Upside
6	Horse power	
7	No. of phase	1: Single phase 3: 3 phase
8	No. of pole	2: 2 pole 4: 4 pole (normal) 6: 6 pole
9	Voltage / Hertz	
10	Model number of pump	

Dimensions

HHS01 for pump VP-F8~20

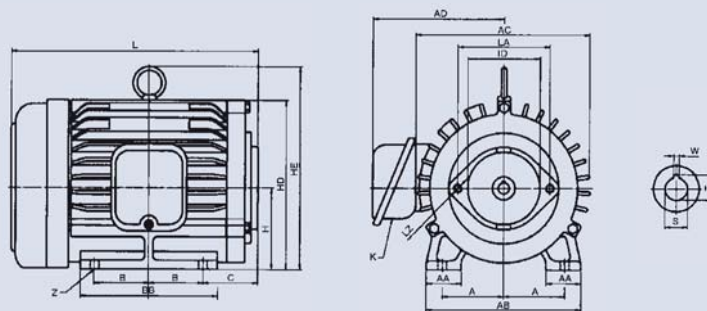

Tolerance
 ID: +0.01~0.03
 S: H7
 T: +0.05~0.1
 W: +0.03~0.05

Power Output (HP)	Frame No.	No. of Phase	A	AA	AB	AC	AD	B	BB	C	H	HD	HE	K	L	Z	Pump Mounting Dimensions						Weight (kg)	
																	LA	LZ	ID	S	T	W		
1/2 1/4	80S	3	62.5	37	156	174	138	50	122	61	80	175	-	22	244	10	106	M10x1.5	82.55	12.7	14.3	3.175	12.5	
1	1/2	80M	3	62.5	37	156	174	138	50	133	67	80	175	-	22	253	10	106	M10x1.5	82.55	12.7	14.3	3.175	16
2	1	90L	3	70	42	179	198	149	62.5	158	57	90	197	-	22	282	10	106	M10x1.5	82.55	12.7	14.3	3.175	23
3	2	100L	3	80	45	196	225	162	70	175	65	100	210	245	22	300	12	106	M10x1.5	82.55	12.7	14.3	3.175	32
5	3	112M	3	95	47	228	234	167	70	178	84	112	232	266	22	333	12	106	M10x1.5	82.55	12.7	14.3	3.175	40
1/2	-	80M	1	62.5	37	156	174	143	50	133	67	80	175	-	28	272	10	106	M10x1.5	82.55	12.7	14.3	3.175	16
1	-	90L	1	70	42	179	198	155	62.5	158	65	90	197	-	28	297	10	106	M10x1.5	82.55	12.7	14.3	3.175	25
2	-	90L	1	70	42	179	198	155	62.5	158	65	90	197	-	28	297	10	106	M10x1.5	82.55	12.7	14.3	3.175	28
3	-	112M	1	95	47	228	234	177	70	178	84	112	235	266	28	343	12	106	M10x1.5	82.55	12.7	14.3	3.175	45

ELECTRIC MOTOR-HOLLOW SHAFT TYPE

Dimensions

HHS01 for pump
A16~22, PVS8~22,
V15~18, HVP-FAI,
VQ15, PV2R1

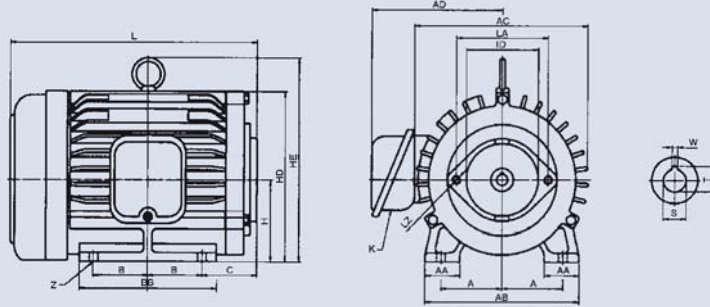

Tolerance
 ID: +0.01~0.03
 S: H7
 T: +0.05~0.1
 W: +0.03~0.05

Power Output (HP)	Frame No.	No. of Phase	A	AA	AB	AC	AD	B	BB	C	H	HD	HE	K	L	Z	Pump Mounting Dimensions					Weight (kg)		
																	LA	LZ	ID	S	T		W	
1	1/2	80M	3	62.5	37	156	174	138	50	133	67	80	175	-	22	257	10	106	M10x1.5	82.55	19.05	21.7	4.8	16
2	1	90L	3	70	42	179	198	149	62.5	158	62	90	197	-	22	275	10	106	M10x1.5	82.55	19.05	21.7	4.8	23
3	2	100L	3	80	45	196	225	162	70	175	65	100	210	245	22	300	12	106	M10x1.5	82.55	19.05	21.7	4.8	32
5	3	112M	3	95	47	228	234	167	70	178	84	112	232	266	22	333	12	106	M10x1.5	82.55	19.05	21.7	4.8	40
7 1/2	5	132S	3	108	47	255	266	185	70	176	81	132	270	304	28	352	12	106	M10x1.5	82.55	19.05	21.7	4.8	52
10	7 1/2	132M	3	108	57	255	266	185	89	214	75	132	270	312	28	386	12	106	M10x1.5	82.55	19.05	21.7	4.8	75
1	-	90L	1	70	42	179	198	155	62.5	158	70	90	197	-	28	306	10	106	M10x1.5	82.55	19.05	21.7	4.8	25
2	-	90L	1	70	42	179	198	155	62.5	158	70	90	197	-	28	306	10	106	M10x1.5	82.55	19.05	21.7	4.8	28
3	-	112M	1	95	47	228	234	177	70	178	84	112	232	266	28	343	12	106	M10x1.5	82.55	19.05	21.7	4.8	45
5	-	112M	1	95	47	228	234	177	70	178	99	112	235	266	28	373	12	106	M10x1.5	82.55	19.05	21.7	4.8	50

Dimensions

HHS01 for pump
V23~42, A36~37,
PVS35~45,
VQ25, KT6C

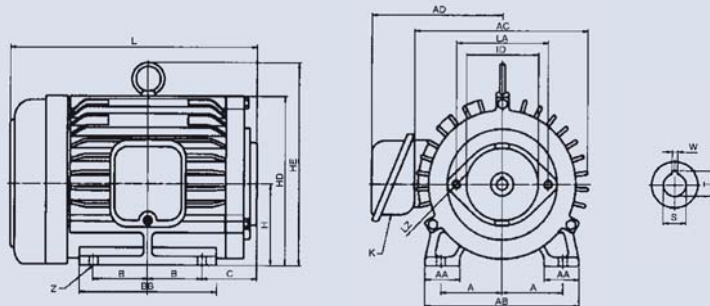

Tolerance
 ID: +0.01~0.03
 S: H7
 T: +0.05~0.1
 W: +0.03~0.05

Power Output (HP)	Frame No.	No. of Phase	A	AA	AB	AC	AD	B	BB	C	H	HD	HE	K	L	Z	Pump Mounting Dimensions					Weight (kg)		
																	LA	LZ	ID	S	T		W	
3	2	112S	3	95	47	228	234	167	70	171	60	112	235	270	22	290	12	146	M12x1.75	101.6	22.23	25.08	6.35	32
5	3	112M	3	95	47	228	234	167	70	178	82	112	232	266	22	331	12	146	M12x1.75	101.6	22.23	25.08	6.35	40
7 1/2	5	132S	3	108	47	255	266	185	70	176	85	132	270	304	28	357	12	146	M12x1.75	101.6	22.23	25.08	6.35	52
10	7 1/2	132M	3	108	57	255	266	185	89	214	82	132	270	312	28	390	12	146	M12x1.75	101.6	22.23	25.08	6.35	75
3	-	112M	1	95	47	228	234	177	70	178	82	112	235	266	28	341	12	146	M12x1.75	101.6	22.23	25.08	6.35	45
5	-	112M	1	95	47	228	234	177	70	178	97	112	235	266	28	371	12	146	M12x1.75	101.6	22.23	25.08	6.35	50

ELECTRIC MOTOR-HOLLOW SHAFT TYPE

Dimensions

HHS01 for pump NOP, TOP

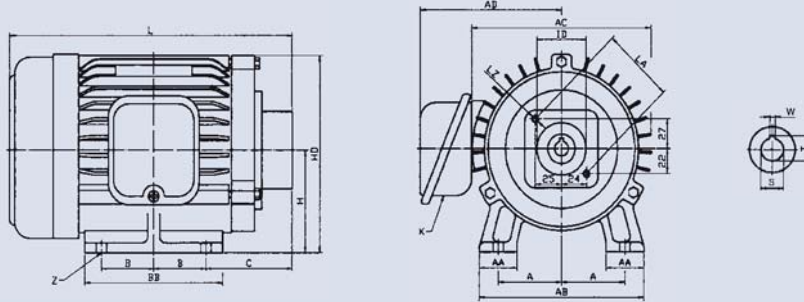

Tolerance
 ID: +0.01~0.03
 S: H7
 T: +0.05~0.1
 W: +0.03~0.05

Power Output (HP)		Frame No.	No. of Phase	A	AA	AB	AC	AD	B	BB	C	H	HD	HE	K	L	Z	Pump Mounting Dimensions						Weight (kg)
4P	6P																	LA	LZ	ID	S	T	W	
1/2	1/4	80S	3	62.5	37	156	174	138	50	122	74	80	175	-	22	257	10	68	M8x1.25	47	14	16	4	12.5
1	1/2	80M	3	62.5	37	156	174	138	50	133	80	80	175	-	22	266	10	68	M8x1.25	47	14	16	4	16
2	1	90L	3	70	42	179	198	149	62.5	158	75	90	197	-	22	288	10	68	M8x1.25	47	14	16	4	23
1/2	-	80M	1	62.5	37	156	174	138	50	133	80	80	175	-	22	285	10	68	M8x1.25	47	14	16	4	16
1	-	90L	1	70	42	179	198	155	62.5	158	83	90	197	-	28	310	10	68	M8x1.25	47	14	16	4	25
2	-	90L	1	70	42	179	198	155	62.5	158	83	90	197	-	28	310	10	68	M8x1.25	47	14	16	4	28

Dimensions

HHS01 for pump 50T

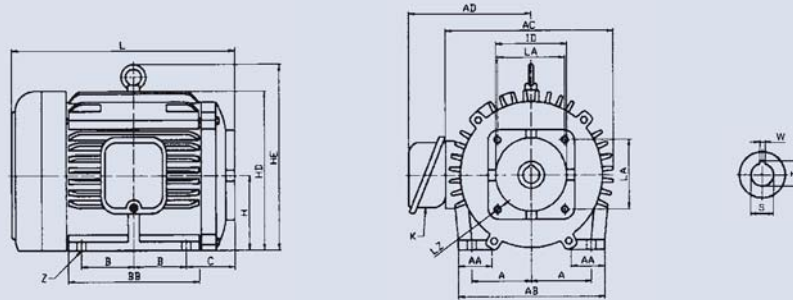

Tolerance
 ID: +0.01~0.03
 S: H7
 T: +0.05~0.1
 W: +0.03~0.05

Power Output (HP)		Frame No.	No. of Phase	A	AA	AB	AC	AD	B	BB	C	H	HD	HE	K	L	Z	Pump Mounting Dimensions						Weight (kg)
4P	6P																	LA	LZ	ID	S	T	W	
2	1	90L	3	70	42	179	198	149	62.5	158	56	90	197	-	22	270	10	90	M10x1.5	96	22	24	5	23
3	2	100S	3	80	45	196	225	162	70	175	65	100	210	245	22	300	12	90	M10x1.5	96	22	24	5	32
5	3	112M	3	95	47	228	234	167	70	178	85	112	232	266	22	344	12	90	M10x1.5	96	22	24	5	40
7 1/2	5	132S	3	108	47	255	266	185	70	176	81	132	270	304	28	352	12	90	M10x1.5	96	22	24	5	52
10	7 1/2	132M	3	108	57	255	266	185	89	214	75	132	270	312	28	386	12	90	M10x1.5	96	22	24	5	75
2	-	90L	1	70	42	179	198	155	62.5	158	56	90	197	-	28	300	10	90	M10x1.5	96	22	24	5	28
3	-	112M	1	95	47	228	234	177	70	178	85	112	235	266	28	344	12	90	M10x1.5	96	22	24	5	45
5	-	112M	1	95	47	228	234	177	70	178	100	112	235	266	28	374	12	90	M10x1.5	96	22	24	5	50

ELECTRIC MOTOR-HOLLOW SHAFT TYPE

Dimensions

HHS01 for pump HGP-1A (4BE)

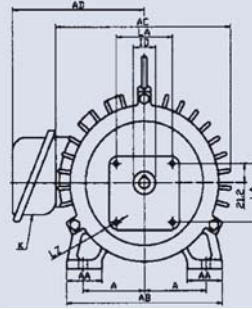
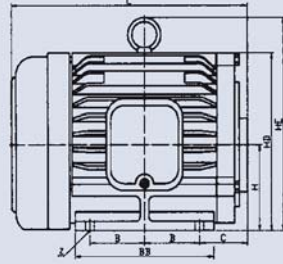

Tolerance
 ID: +0.01~0.03
 S: H7
 T: +0.05~0.1
 W: +0.03~0.05

Power Output (HP)		Frame No.	No. of Phase	A	AA	AB	AC	AD	B	BB	C	H	HD	HE	K	L	Z	Pump Mounting Dimensions						Weight (kg)
4P	6P																	LA	LZ	ID	S	T	W	
1/2	1/4	80S	3	62.5	37	156	174	138	50	122	56	80	175	-	22	239	10	64	M6x1.0	30	12	13.7	4	12.5
1	1/2	80M	3	62.5	37	156	174	138	50	133	62	80	175	-	22	248	10	64	M6x1.0	30	12	13.7	4	16
2	1	90L	3	70	42	179	198	149	62.5	158	55	90	197	-	22	268	10	64	M6x1.0	30	12	13.7	4	23
3	2	112S	3	95	47	228	234	167	70	171	57	112	235	270	22	287	12	64	M6x1.0	30	12	13.7	4	32
1/2	-	80M	1	62.5	37	156	174	143	50	133	62	80	175	-	28	270	10	64	M6x1.0	30	12	13.7	4	16
1	-	90L	1	70	42	179	198	155	62.5	158	63	90	197	-	28	297	10	64	M6x1.0	30	12	13.7	4	25
2	-	90L	1	70	42	179	198	155	62.5	158	63	90	197	-	28	297	10	64	M6x1.0	30	12	13.7	4	28
3	-	112M	1	95	47	228	234	177	70	178	82	112	235	266	28	347	12	64	M6x1.0	30	12	13.7	4	45

Dimensions

HHS01 for pump HGP-2A, PA

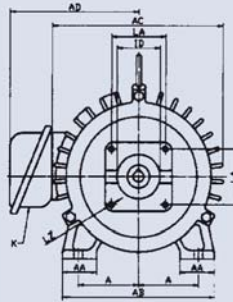
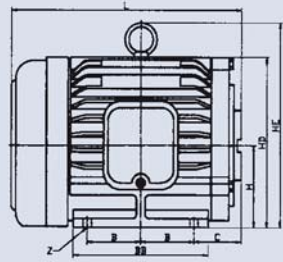

Tolerance
 ID: +0.01~0.03
 S: H7
 T: +0.05~0.1
 W: +0.03~0.05

Power Output (HP)		Frame No.	No. of Phase	A	AA	AB	AC	AD	B	BB	C	H	HD	HE	K	L	Z	Pump Mounting Dimensions						Weight (kg)
4P	6P																	LA	LZ	ID	S	T	W	
1/2	1/4	80S	3	62.5	37	156	174	138	50	122	58	80	175	-	22	241	10	63.5	M8x1.25	50.77	12.5	14	4	12.5
1	1/2	80M	3	62.5	37	156	174	138	50	133	64	80	175	-	22	250	10	63.5	M8x1.25	50.77	12.5	14	4	16
2	1	90L	3	70	42	179	198	149	62.5	158	57	90	197	-	22	270	10	63.5	M8x1.25	50.77	12.5	14	4	23
3	2	100L	3	80	45	196	225	162	70	175	65	100	210	245	22	300	12	63.5	M8x1.25	50.77	12.5	14	4	32
5	3	112M	3	95	47	228	234	167	70	178	84	112	235	266	22	333	12	63.5	M8x1.25	50.77	12.5	14	4	40
1/2	-	80M	1	62.5	37	156	174	143	50	133	64	80	175	-	28	272	10	63.5	M8x1.25	50.77	12.5	14	4	16
1	-	90L	1	70	42	179	198	155	62.5	158	65	90	197	-	28	295	10	63.5	M8x1.25	50.77	12.5	14	4	25
2	-	90L	1	70	42	179	198	155	62.5	158	65	90	197	-	28	295	10	63.5	M8x1.25	50.77	12.5	14	4	28
3	-	112M	1	95	47	228	234	177	70	178	84	112	235	266	28	343	12	63.5	M8x1.25	50.77	12.5	14	4	45
5	-	112M	1	95	47	228	234	177	70	178	99	112	235	266	28	373	12	63.5	M8x1.25	50.77	12.5	14	4	50

ONE WAY ROTATION OIL PUMP, ELECTRO-MAGNETIC COOLANT PUMP

One way rotation pump

FEATURES:

1. The model 1A oil pumps are the most suitable not only for various machine tools and industry machines, but also for various automotive and agricultural machinery engines which are needed by the unit of hundreds or thousands. The special type of the pump for fixtrue is also supplied by your requirement.
2. Relief valve is assembled on the top part of the pump. If you need the valve, please mark your order by indicating with relief valve, it is marked at the end of pump marking by symbol VB. The standard pressure setting is 3 kg/cm².

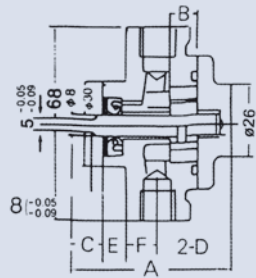
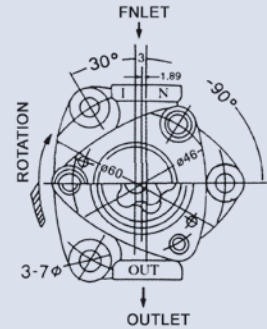
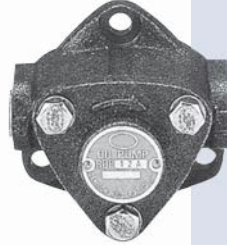

Specifications

Model	Delivery (lpm) AT 1000 rpm	Max. Pressure (bar)	Max. Running speed (rpm)	Port Size (pt)	Weight (kg)
ROP-10A	0.8	5	3000	1/8"	0.55
ROP-11A	1.5	5	3000	1/8"	0.55
ROP-12A	2.5	5	2000	1/4"	0.62
ROP-13A	4.5	5	2000	3/8"	0.82

Dimensions

Model	A	B	C	E	F	Port size D (pt)
ROP-10A	57	5	11.5	8	11	1/8
ROP-11A	57	9	11.5	8	11	1/8
ROP-12A	64	15	11.5	8	11	1/4
ROP-13A	79	27	14.5	5	14	3/8

Electro-magnetic coolant pump

FEATURES:

Patented design: No motor needed unique electro-magnetic power system coolant is pumped using vibratory action cost 50% less than conventional pumps takes up very little space easily portable.

Designed for small lathes, grinder, milling and drill.

Pressure: Closed tip under 1 bar. The flow rate of the oil or lubricant used is directly proportional to its viscosity.

WL-1
WE-1



WL-2
WE-2

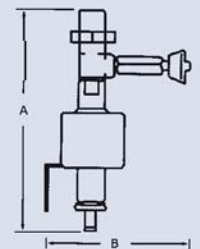

Specifications

Model	Power (W)	Voltage (V)	Absorbent (M)	Flow (lpm)		Dimension		Weight (kg)
				Turbine oil #140	Engine oil #90	A	B	
WE-1	25	AC 110 or AC 220	1~1.5	25	10	148	84	0.90
WE-2				192	129	1.10		
WL-1	13	AC 220	1~1.5	6	3	113	53	0.32
WL-2				150	98	0.42		

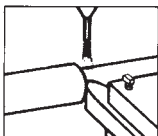

* **LATHE**
Cutting Oil supply

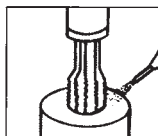

* **DRILL**
* **TURBINE**
Cutting Oil supply

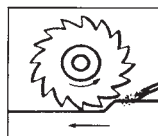

* **NC WORKING MACHINE**
Slit face lubricant supply

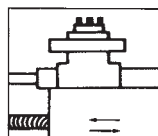

* **MILLING**
Cutting Oil supply

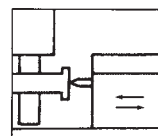

* **GRINDER**
Slit face lubricant supply

Fitting method

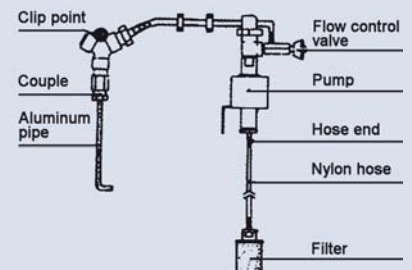

MANUAL OPERATED LUBRICATOR

How to order

LT - 6 - ✖
 1 2 3

- | | |
|----------|---|
| 1 | Model |
| 2 | Displacement cc/stroke 8A, 8B (see installation size) 6W, 8W (with pressure-relief) |
| 3 | Port size |

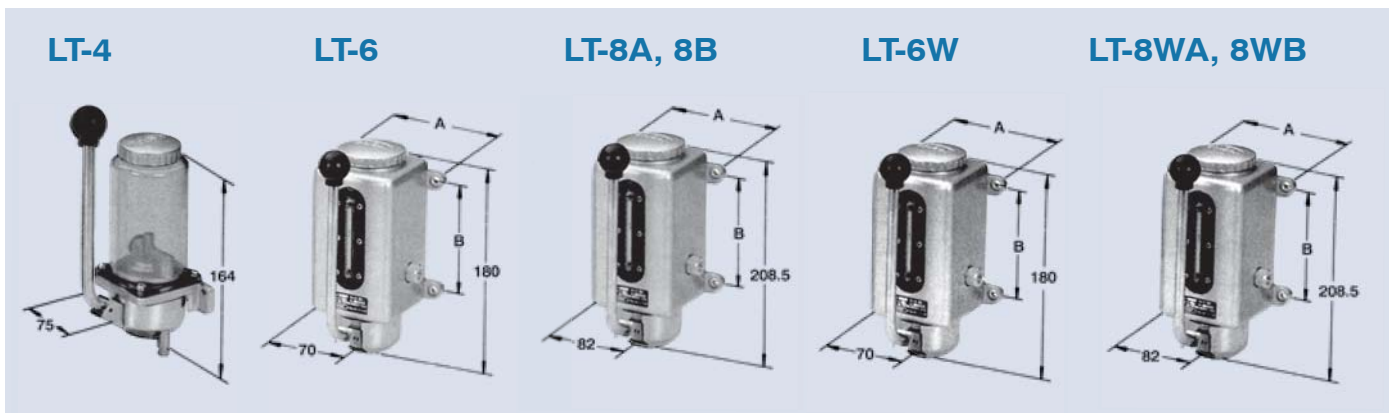

Features for 6W, 8W

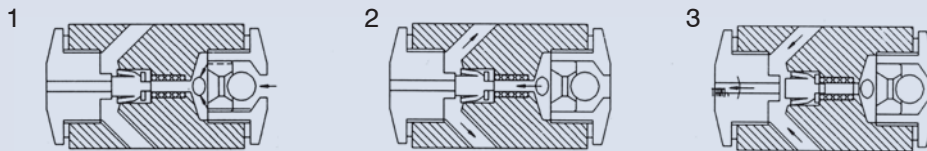

1. The piston valve is open for oil inflow and store it.
2. The stored oil is being distributed to each outlet port through the check valve.
3. The unused oil is returning to the relief port after the oil released by piston valve and the check valve is closed.

Specifications

Model	Displacement (cc/stroke)	Capacity (cc)	Max. Pressure (bar)	Installation Size (A x B)	Port Size	Weight (kg)
LT-4	4	230	15	75	4 or 6 mm	0.7
LT-6	6	350	15	85 x 85	1/8 PT	1.2
LT-8A	8	600	15	98 x 107	1/8 PT	1.6
LT-8B	8	650	15	100 x 110	1/8 PT	1.6
LT-6W	6	350	30	85 x 85	1/8 PT	1.2
LT-8WA	8	600	30	98 x 107	1/8 PT	1.6
LT-8WB	8	650	30	100 x 110	1/8 PT	1.6

MOTOR-TYPE ENGINE OIL/GREASE OILER



1 Motor AC 110V/220V 50/60HZ Single phase MSK-601: AC110V MSK-602: AC220V

2 Overload fuse 3A

3 Application For various machine lubrication

Operation of time controller (YTCB) INT: For setting motor interval, OFF-TIME set is available for 1-99 minutes.
 DIS: For setting pump working, OFF-TIME set is available for 1-99 seconds.
 FEED: For manual oiling control (stop upon release)
 RST: For manual oiling according to seconds set by "DIS" key.

4 Cautions & maintenance service

- The power to be supplied must be same as specified on machine.
- During installation, follow the instructions for wiring to prevent controller from damage.
- Earthing is necessary for safe reason.
- Always fill oil tank through oil hole to avoid vacuum tank.
- Prevent control circuit from contacting oil, water or any other objects for good condition.
- Always add oil according to instructions to prevent overflow.
- Prevent machine from impact.

5 Machine functions

- Pressure output is fulfilled by an adjustable constructure, applicable for every kind of machine and available for relative prepressure supply/adjustment.
- Immediate button is able to provide machine with required oil volume at beginning so as to smoothly start the machine and reduce unnecessary abrasion.
- Time-control device is provided to carry out double-step adjustment between oil supply and intermission.

Dimensions

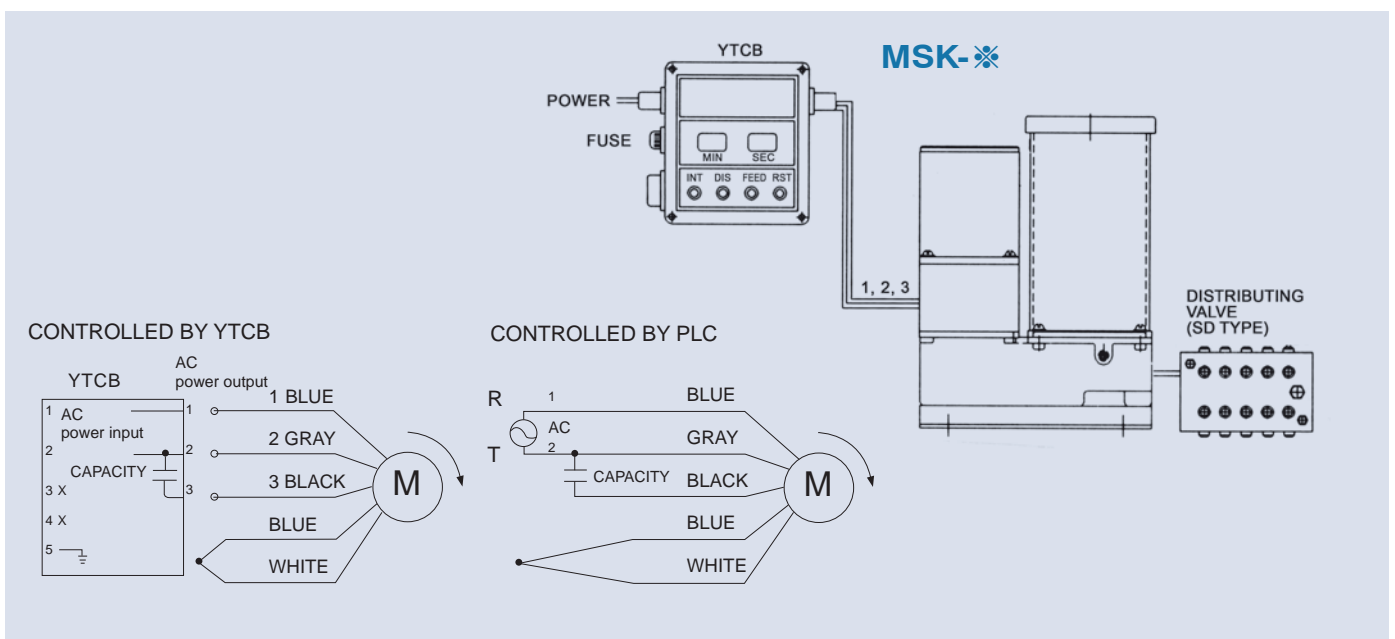

MOTOR-TYPE ENGINE OIL/GREASE OILER

Specifications

Without Time Control

Model	Flow (cc/min)	Voltage (50/60HZ)	Power	Oil Tank Capacity	Max. Output Pressure	Oil Viscosity (cst)	Weight (kg)
MSK-601	60	110V	40W	1.5L	100 bar	00 #	6.5
MSK-602		220V				0 #	

With Time Control

Model	Flow (cc/min)	Voltage (50/60 HZ)	Power	Oil Tank Capacity	Intermittent off Time	Running Time	Max. Output Pressure	Oil Viscosity (cst)	Weight (kg)
MSK-601C	60	110V	40W	1.5L	1~99 min	1~99 sec. (YTCB control)	100 bar	00 #	8
MSK-602C		220V				1~99 times (YCCB control)		0 #	

Mounting types / Dimensions

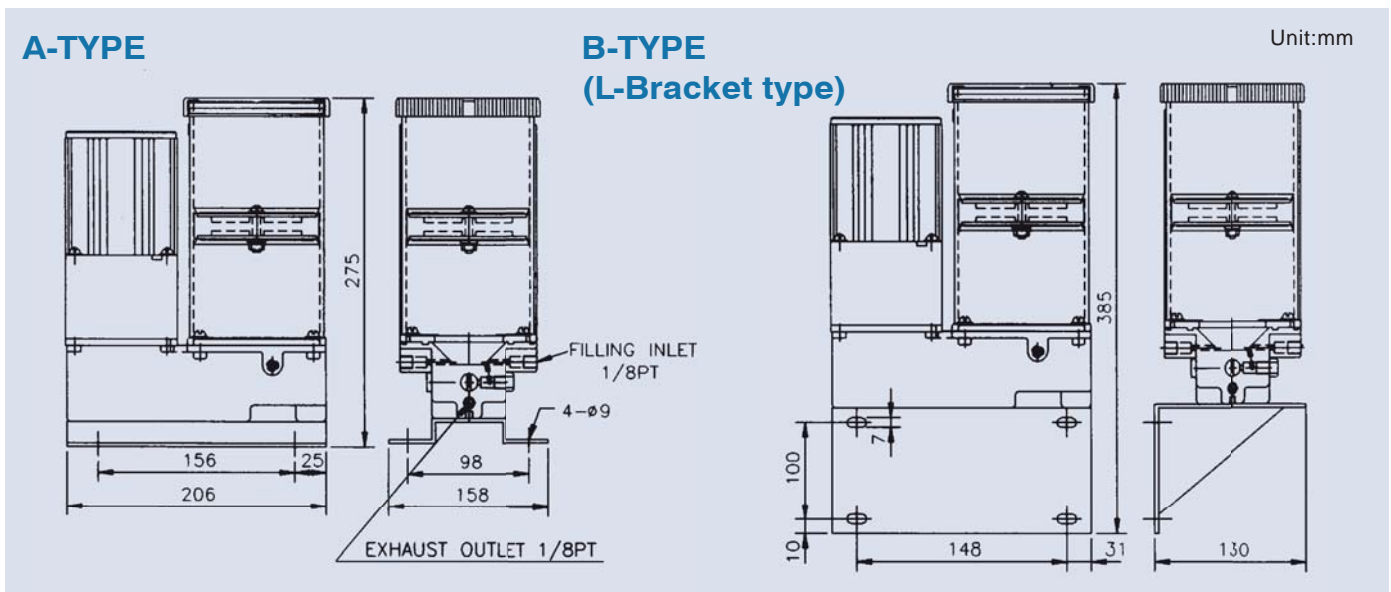

Single cycle oil distributor



COUNTER CONTROL BOX FOR MSK-SERIES

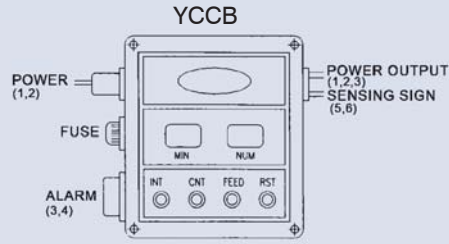

- 1** Power source adapter
1, 2: Power input 3, 4: Alarm power 5: Earth
- 2** Power out put
1, 2, 3: Motor power 4: C common 5: A contact (normal closed) 6: B contact (normal open)
- 3** Operation
 INT: For setting lubricating interval time, available from 1-99 minutes.
 CNT: For setting lubricating frequency, available from 1-99 times.
 FEED: For manual lubricating, push for discharge.
 RST: For one cycle lubricating, lubricating frequency set by CNT.
 1. Power: AC 110V/220V 50/60 HZ, single phase
 2. Overload fuse : 3A

- 3. Alarm output circuit (Max.): 1A
- 4. Motor power (Max.): 3A
- 5. YCCB counter box is suitable for MSK series grease oiler with SD-※S distributor used, can precise control lubricating volume and frequency in each lubrication line. For machine long machine life.

Dimensions

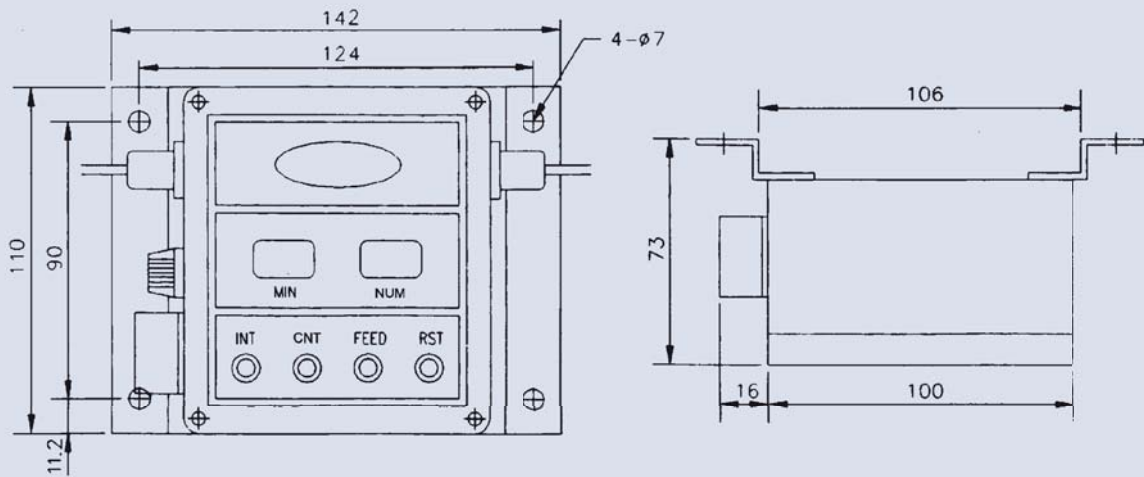

Unit:mm

YSA check box connecting

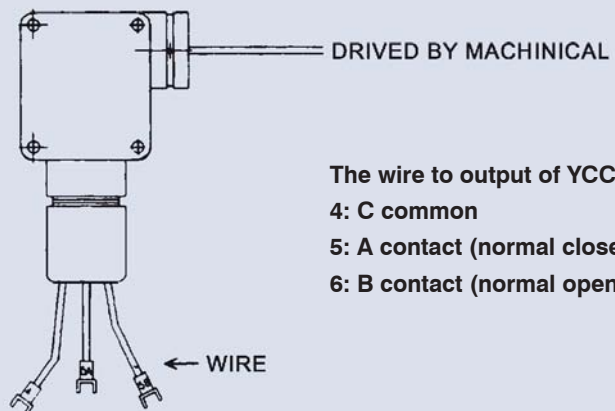

The wire to output of YCCB:
 4: C common
 5: A contact (normal closed)
 6: B contact (normal open)

MOTOR OPERATED INTERMITTENT AUTOMATIC LUBRICATOR



How to order

KCMM-2 - 15 - 6 - A1

	1	2	3	4
1	Model	KCMM-2: Normal type	KCMM-2A: With alarm system	KCMM-2F: With float switch
2	Interval time	5, 10, 15, 30 minutes		
3	Outlet port	4: 4mm	6: 6mm	
4	Voltage	A1: AC110V	A2: AC220V	

FEATURES:

- Use the recommended oil only. (#M32 or #68)
- The motor should be turned clockwise when looking down through the upper side.
- It is fail to take off the locknut located at the upper side of the instant feed button when making adjustment the discharge amount of oil.
- If the motor has not been used for long time, pull the manual handle for 4 to 5 times before starting the motor, don't try to force to push handle returns to its original position when manual operation.
- Clean the filter or replace it with a new one once a year or more often.

How to adjust discharge oil amount of automatic intermittent lubricating pump:

- Fix the tip of piston rod (*) by ⊖ screwdriver, and loosen locknut ① counter clockwise.
- Turn the connecting rod ② to set it at the standard position after loosening the locknut ① and fix it firmly in that position.
- The graduation and discharge amount are shown in the diagram on the right.

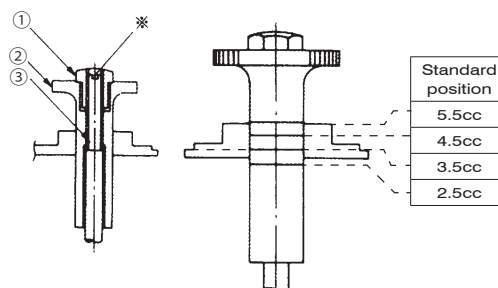

Specifications

Model	Interval Time (minute)	Discharge Pressure (bar)	Displacement (cc/shot)	Outlet Dia. (mm)	Voltage	Tank Vol.	Effective Vol.	Weight (kg)
KCMM-2	5, 10, 15, 30	2.5~3	2.5~5.5	ø4 or ø6	110V or 220V	2000 cc	1800 cc	2.4
KCMM-2A	5, 10, 15, 30	2.5~3	2.5~5.5	ø4 or ø6	110V or 220V	2000 cc	1800 cc	2.5
KCMM-2F	5, 10, 15, 30	2.5~3	2.5~5.5	ø4 or ø6	110V or 220V	2000 cc	1800 cc	2.5

Motor terminal wiring diagram / Dimensions

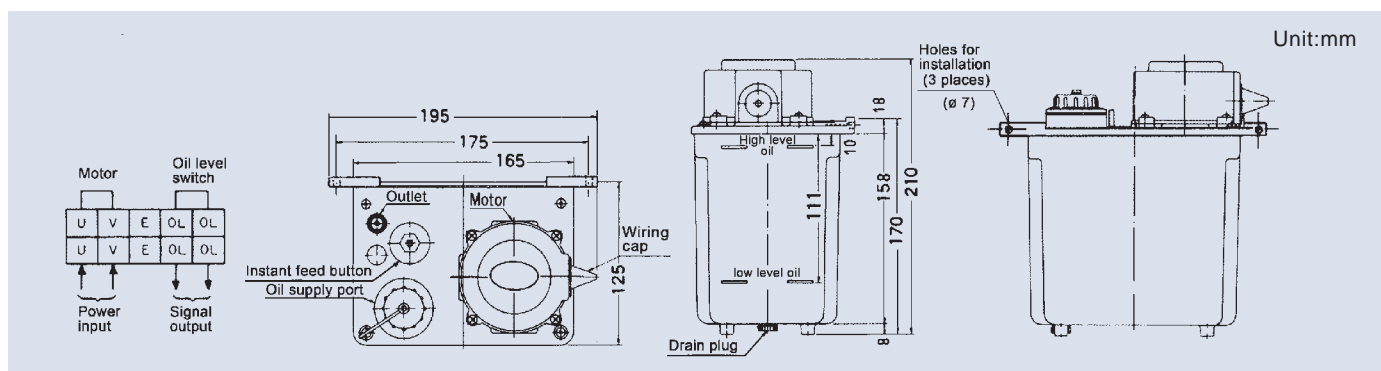

Unit:mm

ELECTRIC CONTROL LUBRICATOR

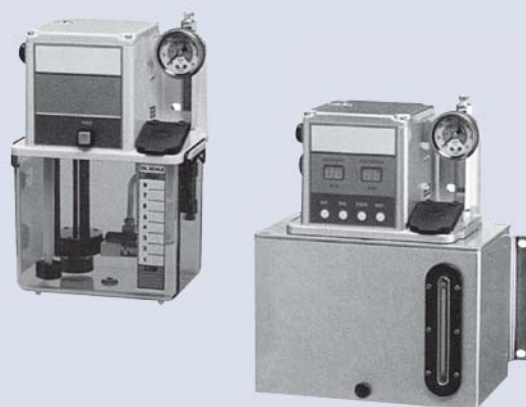

How to order

TM - 3 01 C F W - T 2 P

1 2 3 4 5 6 7 8 9

1	Model																																												
2	Discharge (lpm) 3: 0.24 (for TM-3F, 3CF, 3FW, 3CFW) 5: 0.34 (for TM-3F, 3CF)																																												
3	Power voltage 01: 110V 02: 220V (50/60HZ)																																												
4	With timer controller																																												
5	With float switch (A, B contact)																																												
6	With pressure release																																												
7	With tank																																												
8	Tank capacity (liter)																																												
	<table border="1"> <thead> <tr> <th rowspan="2">Tank Code</th> <th colspan="2">Tank capacity (ℓ)</th> <th rowspan="2">Tank code</th> <th colspan="2">Tank capacity (ℓ)</th> <th rowspan="2">Tank Code</th> <th colspan="2">Tank capacity (ℓ)</th> <th rowspan="2">Tank code</th> <th colspan="2">Tank capacity (ℓ)</th> </tr> <tr> <th>Full</th> <th>Effective</th> <th>Full</th> <th>Effective</th> <th>Full</th> <th>Effective</th> <th>Full</th> <th>Effective</th> </tr> </thead> <tbody> <tr> <td>2P</td> <td>2</td> <td>1.8</td> <td>4P</td> <td>3.5</td> <td>3.1</td> <td>4A</td> <td>3.5</td> <td>2.8</td> <td>8A</td> <td>7.8</td> <td>7.5</td> </tr> <tr> <td>3P</td> <td>2.6</td> <td>2.3</td> <td>3A</td> <td>2.6</td> <td>2.1</td> <td>6A</td> <td>6.2</td> <td>5.1</td> <td>12S</td> <td>11.5</td> <td>9.8</td> </tr> </tbody> </table>	Tank Code	Tank capacity (ℓ)		Tank code	Tank capacity (ℓ)		Tank Code	Tank capacity (ℓ)		Tank code	Tank capacity (ℓ)		Full	Effective	Full	Effective	Full	Effective	Full	Effective	2P	2	1.8	4P	3.5	3.1	4A	3.5	2.8	8A	7.8	7.5	3P	2.6	2.3	3A	2.6	2.1	6A	6.2	5.1	12S	11.5	9.8
Tank Code	Tank capacity (ℓ)		Tank code	Tank capacity (ℓ)		Tank Code	Tank capacity (ℓ)		Tank code	Tank capacity (ℓ)																																			
	Full	Effective		Full	Effective		Full	Effective		Full	Effective																																		
2P	2	1.8	4P	3.5	3.1	4A	3.5	2.8	8A	7.8	7.5																																		
3P	2.6	2.3	3A	2.6	2.1	6A	6.2	5.1	12S	11.5	9.8																																		
9	Tank material P: Plastic transparent tank (for 2~4L) A: Aluminum tank (for 3~8L) S: Steel tank (for 12L)																																												

Specifications

Motor (shield type)					Working Pressure	Sensing Pressure (optional for 3FW, 3CFW)	
Power	Voltage	Max. Shielding		Phase		in	off
		Voltage	Current				
150W	AC110V or AC220V (50/60 HZ)	AC250V	3A	single	150 bar	12 bar	8 bar

Resisting type

Model	Flow (lpm)	Volt	Floating Switch	Pres. Release Dev.	Working Pres. (bar)	Off Time	Running Time
TM-301F	0.24 or 0.34	110V	0	X	1~10	PLC control	PLC control
TM-302F		220V	0	X	1~10		
TM-301CF		110V	0	X	1~10	1~99 min	1~99 sec
TM-302CF		220V	0	X	1~10		

Pressure release type

Model	Flow (lpm)	Volt	Floating Switch	Pres. Release Dev.	Working Pres. (bar)	Off Time	Running Time
TM-301FW	0.24	110V	0	0	1~15	PLC control	PLC control
TM-302FW		220V	0	0	1~15		
TM-301CFW		110V	0	0	1~15	1~99 min	1~99 sec
TM-302CFW		220V	0	0	1~15		

ELECTRIC CONTROL LUBRICATOR

Description for control wiring

OPERATION WITH TIMER CONTROL

INT KEY: Intermittent time control key. Setting range 1~99 minutes.

DIS KEY: Running time control key. Setting range 1~99 seconds.

FEED KEY: Hand controlled oil discharge (Discharge will stop when the key is released).

RST KEY: Hand discharge according to seconds set by DIS KEY.

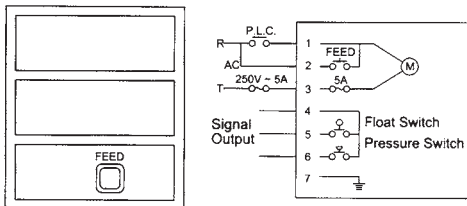

ELECTRIC WIRING DIAGRAM FOR TM-3F, FW

- 1, 3: Input power.
- 2, 3: Hand lubrication control.
- 4, 5: Floating switch. A or B contact. Max. current 250V / 0.1A.
- 4, 6: Pressure sensor. A or B contact. Max. current 250V / 0.1A.
- 7 : Grounding

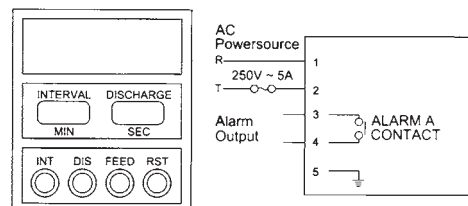

ELECTRIC WIRING DIAGRAM FOR TM-3CF, CFW

- 1, 2: Input power.
- 3, 4: Alarm A contact output. Max. current 1A.
- 5 : Grounding

Dimensions

2L

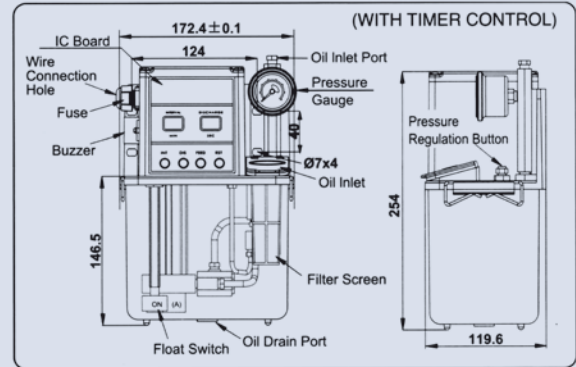
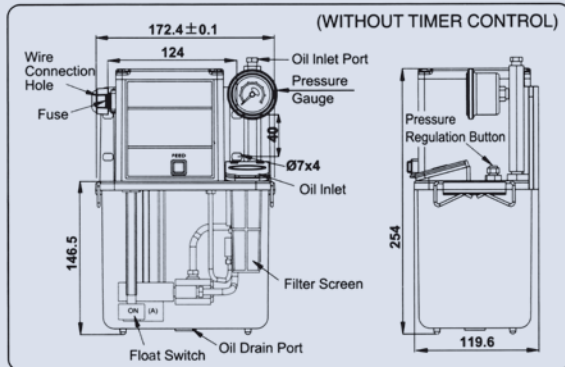

3~12L

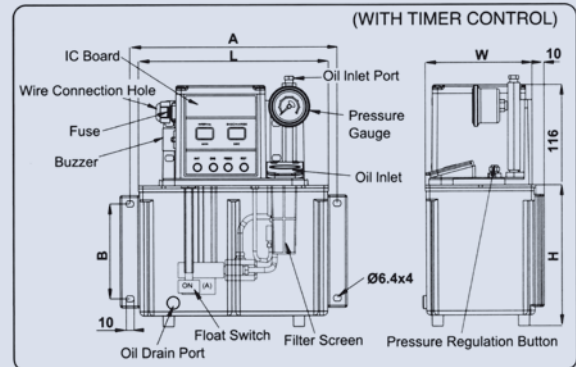
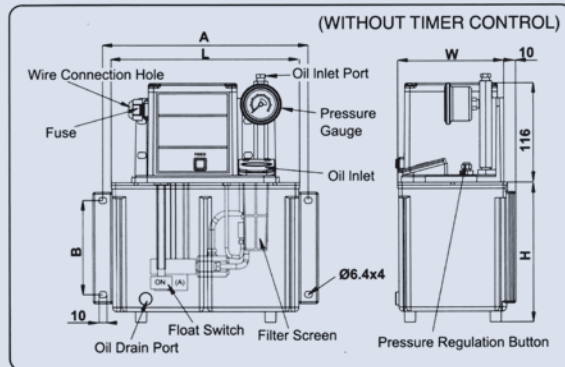

Tank Code	A x B (mm)	L (mm)	W (mm)	H (mm)
T-3L	205 x 95	185	123	142
T-4L	240 x 110	220	130	154
T-6L	318 x 110	300	150	158

Tank Code	A x B (mm)	L (mm)	W (mm)	H (mm)
T-8L	336 x 110	320	173	172
T-10L	370 x 110	320	180	150
T-12L	386 x 110	360	230	152

ELECTRIC CONTROL LUBRICATOR

Reference diagrams for proportional connectors, adjustable distributors and single cycle distributor for TM-3F and TM-3CF



Proportional connectors PSS. PST. PTS. PTT 00# ~5#

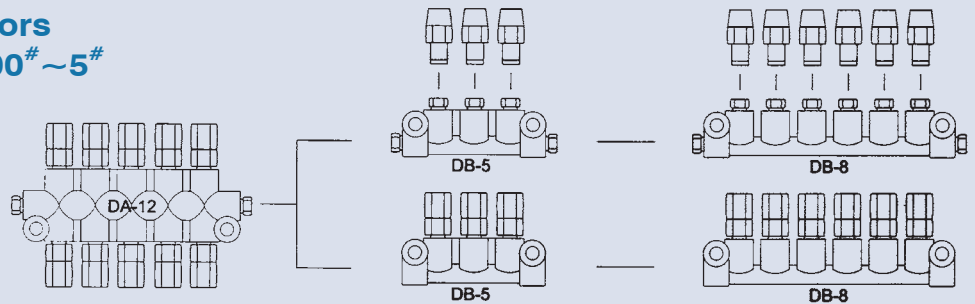

Adjustable connectors VA-(4~18) VB-(4~12) DB-(4A~12A) DB-(4AS~12AS)

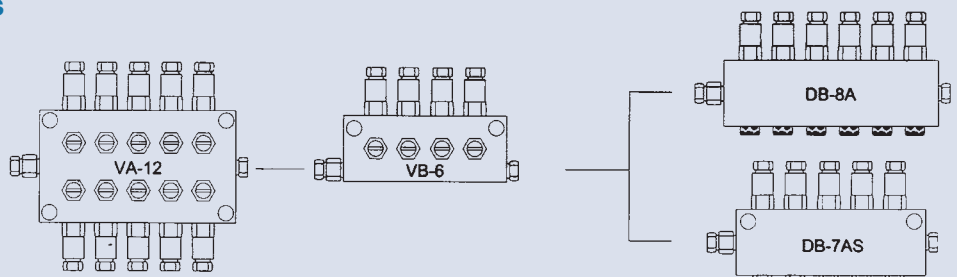

Reference diagrams for constant volumetrical distributors for TM-3FW and TM-3CFW

Constant volumetrical distributors HA-(1~5Hole) 0.03^{cc} ~0.16^{cc} HBL-(1~5Hole) 0.1^{cc} ~0.5^{cc}

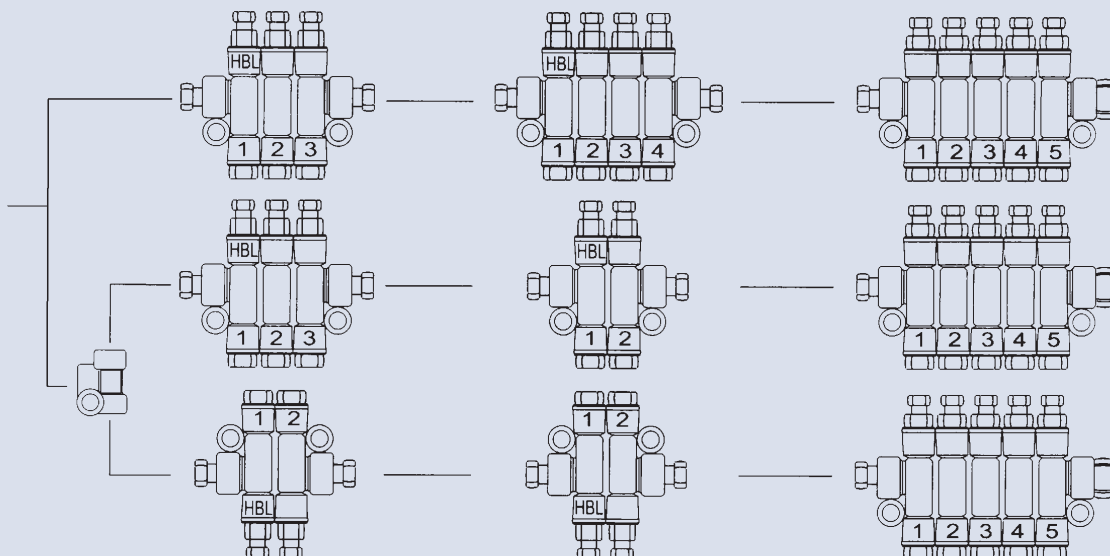

ELECTRIC CONTROL LUBRICATOR

FEATURES:

1. Pressure output is adjustable to suit various machines requiring proper pressure adjustment.
2. Equipped with an oil level sensor to detect the oil amount in the tank. This provides fast response for proper treatment.
3. An instant button allows for enough lubrication oil control when the machine is just starting, preventing serious friction.
4. Bottom oil suction complies with Pascal principle, which not only upgrades oil outlet efficiency, but also helps to remove air in oil hose.
5. Equipped with an oil pressure sensor for detecting the following problems (8-12 bar for model TM-3FW and TM-3CFW):
 - **Hose breakage:**
Sensing by insufficient pressure in oil hose.
 - **Filter jammed:**
Sensing by dirty oil or suction port jamming.
 - **Poor motor:**
Sensing by insufficient motor speed.
 - **Insufficient oil pressure:**
Sensing by old parts or insufficient output efficiency.
 - **No oil in tank:**
Sensing by insufficient oil.

APPLICATION INSTRUCTIONS:

1. The running of model TM-3F and 3FW can be controlled by direct output from PLC or direct or indirect control from external timer.
2. The models TM-3F and 3CF are available to equip with VA, VB, DB-A or DB-AS type adjustable distributor and resisting connector. They permit pressure adjustment to a range of 3-5 bar. It is suggested to avoid too much difference between connector flow specifications. The suggested size combinations are (#0, #1, #2) and (#1, #2, #3)
3. When model TM-3FW or 3CFW is equipped with pressure release device, it is also available to use HA or HBL-HBH type constant volumetric distributor. Upon request, a pressure feedback sensor is available to confirm if the circuit pressure reaches 15 bar standard pressure or not. When using the pressure feedback sensor, it is required to equip with a timer, so that a time delay will occur once the pressure switch is confirmed under normal operation condition of timer. Instead, if pressure can not reach the setting value within 60 seconds, it is necessary to set alarm and turn power off. Then check the problem accordingly.
4. When model TM-3FW or 3CFW is equipped with a volumetric distributor, it is necessary to use high pressure hose to meet the high pressure operation. This will ensure its outstanding performance.
5. When the lubrication pump is used in various-temperature areas, operator should pay attention to oil viscosity variation due to temperature difference. Use only correct grade of oil and pressure. For temperature under 20°C, it is suggested to use ISO VG32 oil. For temperature over 20°C, it is suggested to use ISO VG68 oil for proper viscosity.

NOTICES AND MAINTENANCE

1. Make sure your input power complies with that on the pump.
2. When installing the pump, make wiring according to the instruction manual to prevent damage on the controller.
3. For safety's sake, the lubrication pump must be properly grounded.
4. When filling oil into the tank, make sure the oil enters through the filter screen to prevent oil circuit from jamming.
5. In case filter screen is jammed, clean it immediately to ensure a proper filtration effect.
6. Always keep the control circuit from oil or coolant or contacting with any object to avoid damage.
7. When filling oil into the tank, the oil amount should only reach the oil level line to avoid over-flow.
8. Keep the lubrication pump from bumping.

OIL DISTRIBUTOR FOR ELECTRIC CONTROL LUBRICATOR

K

DA

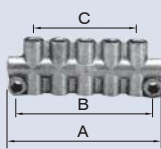

VA

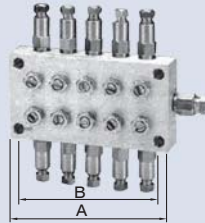

DB

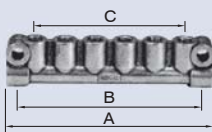

VB

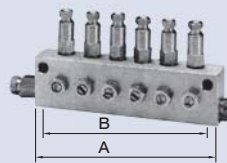

DB-A

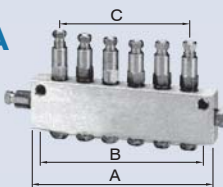

DB-AS

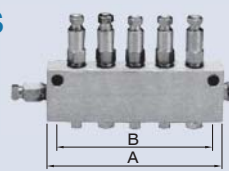

Model	Nos.of port	Dimension (mm)		
		A	B	C
DA-6, VA-6	6	48	36	16
DA-8, VA-8	8	64	52	32
DA-10, VA-10	10	80	68	48
DA-12, VA-12	12	96	84	64
DA-14, VA-14	14	112	100	80
DA-16, VA-16	16	128	116	96
DA-18, VA-18	18	144	132	112
DB-4, VB-4	4	48	36	16
DB-5, VB-5	5	64	52	32
DB-6, VB-6	6	80	68	48
DB-7, VB-7	7	96	84	64
DB-8, VB-8	8	112	100	80
DB-9, VB-9	9	128	116	96
DB-10, VB-10	10	144	132	112
DB-12, VB-12	12	176	164	144
DB-4A (4AS)	4	48	36	16
DB-5A (5AS)	5	64	52	32
DB-6A (6AS)	6	80	68	48
DB-7A (7AS)	7	96	84	64
DB-8A (8AS)	8	112	100	80
DB-9A (9AS)	9	128	116	96
DB10A (10AS)	10	144	132	112
DB12A (12AS)	12	176	164	144

Proportional connector

PSS

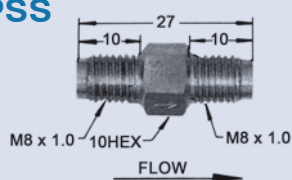

PST

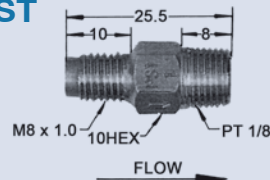

PTS

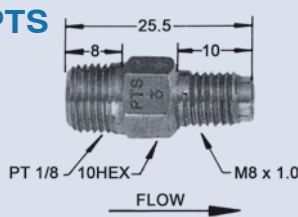

PTT

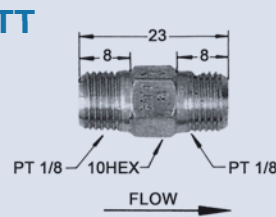

Model	PSS	PST	PTS	PTT	
Displacement code	0	1 2	3 4	5	
Ratio of flow	1	2 4	8 16	32	
Port size	IN	M8x1.0	M8x1.0	PT 1/8	PT 1/8
	OUT	M8x1.0	PT 1/8	M8x1.0	PT 1/8
Working pressure	1.5~20 bar				
Oil viscosity	ISO VG32~68 (40°C)				

Constant volumetrical distributor

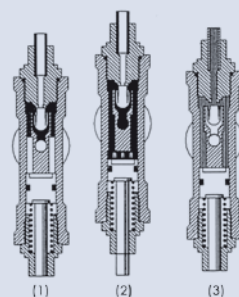
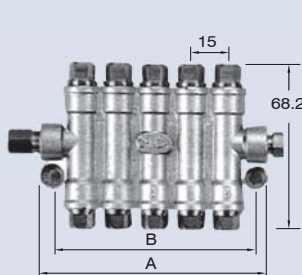

1. The inflowed oil in the distributor making the check valve open.
2. The oil inflow continually and make pressure rise also push the piston valve move back then store oil and pressure.
3. The stored oil returning back to the low pressure inlet line when pump stopped, it will cause check valve closed and the oil flow to outlet port.

Model	HA					HBL					
Numbers of port	1	2	3	4	5	1	2	3	4	5	
Displacement (cc)	0.03, 0.06, 0.10, 0.16					0.1, 0.2, 0.3, 0.4, 0.5					
Min. working pressure (bar)	5					5					
Dimensions (mm)	B	24	39	54	69	84	24	39	54	69	84
	A	35	50	65	80	95	35	50	65	80	95